

ELECON

# ET Series

Helical /Bevel Helical Gear Units

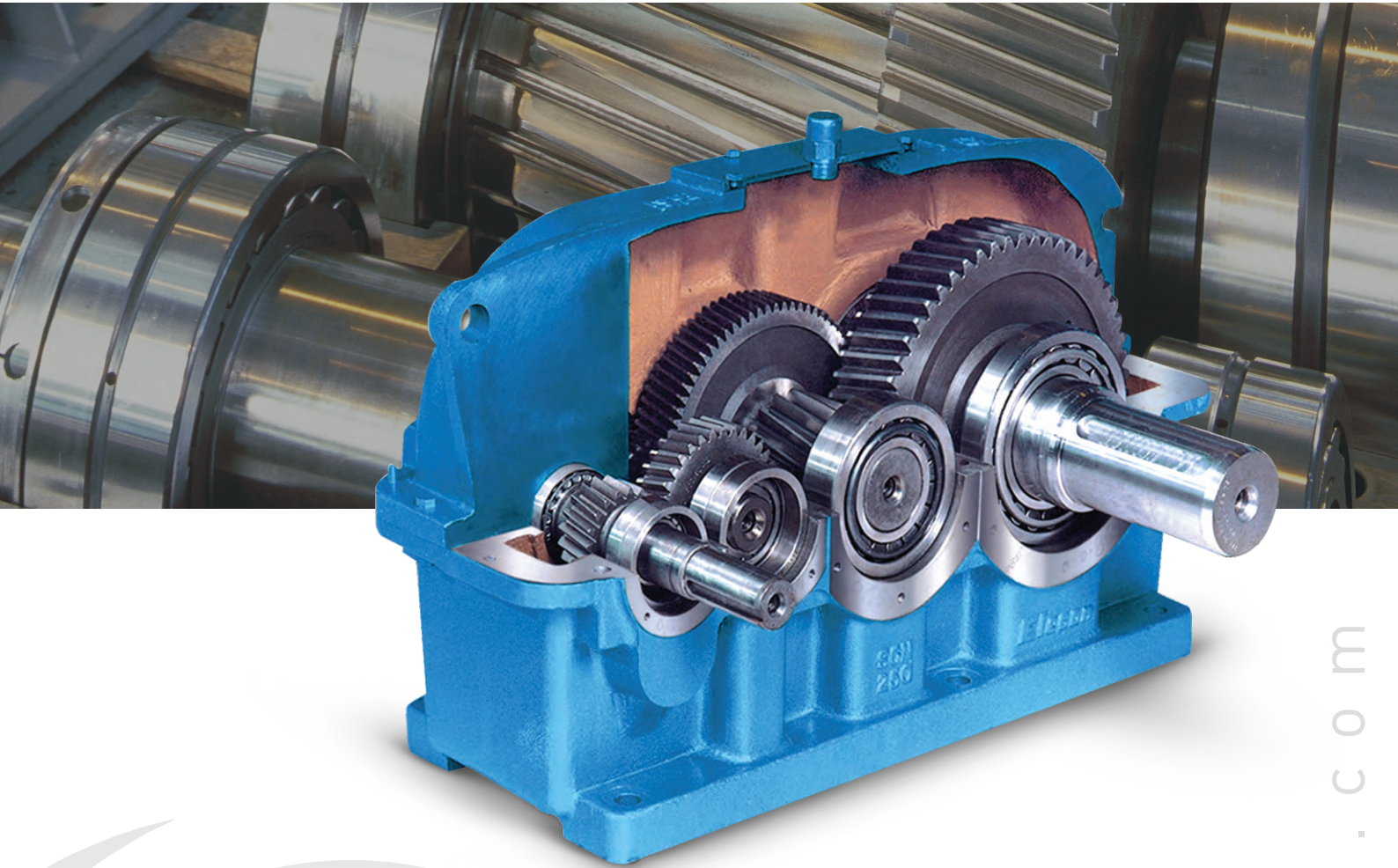

www.elecon.com

## Characteristic and Advantages of the ET - SERIES GEAR UNITS

### Modular design principle

Gear sizes, transmission ratios and main dimensions according to standard series of numbers, economic mass production, comprehensive maintenance of stocks, favourable delivery periods, easy servicing, low weight, compact design with high efficiency due to case-hardened steels of the highest strength, amply dimensioned bearings, very smooth running with low noise due to ground helical gears and lapped high precision spiral bevel gears, housing of vibration-damping design of grey cast iron, the use of the most up-to-date machining equipment with constant production control by means of the most recent measuring machines.

ELECON ET - Series modular gear units are the result of decades of experience in design and production, taking advantage of the most recent relevant research in the field of gearing technology.

### General information

#### Technical

The power tables apply to normal conditions, i.e., drive by an electric motor, smooth operation, operation for eight hours per day, 2.5-fold starting torque relative to catalogue performance  $P_N$ , 100% duration of operation, ambient temperature 20° C. Power for intermediate speeds can be interpolated linearly. Higher drive speeds than indicated and selection as finite-fatigue strength gears on request.

Reinforced bearings are optional for heavy external forces (e. g. output drive by pinion).

### Efficiencies

99 % for single reduction helical gear boxes  
98 % for double reduction helical gear boxes  
97.5% for triple reduction helical gear boxes  
97% for quadruple reduction helical gear boxes  
98% for single reduction bevel gear boxes  
97.5% for double reduction bevel helical gear boxes  
97% for triple reduction bevel helical gear boxes  
96.5% for quadruple reduction bevel helical gear boxes

### Dimensions, weight, oil quantity

The figures are not strictly binding. We reserve the right to modify dimensions. The indicated weight and oil quantities are average values. When filling gear unit with oil, note oil level markings.

### Additional equipment

The housing can be made of nodular cast iron or of fabricated steel. Additional heating cartridges can be built into the housings. Special seals may be provided when the plant has to be set up in dusty or humid surrounding.

### Mounting

Before the gear unit is set up the operating instructions should be studied and followed. Inclined positions for installation are possible on request. The plant user should provide protection covers on rotating parts.

### Noise level :

Allowable noise level is generally as mentioned below

- (a) Gearbox with C.I. housing: 85 d B
- (b) Gearbox with fabricated housing: 90 d B
- (c) Gearbox with fan or built in pump will have 5 d B higher than (a) & (b).

### Vibration level :

Allowable vibration limits is generally as per VDI-2056 group 'T'

Selection of gear



Single reduction helical gear SAN  
 $i_N = 1.6$  to 6.3



Double reduction helical gear SBN  
 $i_N = 6.3$  to 22.4



Triple reduction helical gear SCN  
 $i_N = 14$  to 112

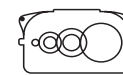

Quadruple reduction helical gear SDN  
 $i_N = 112$  to 630

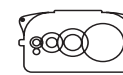

Double reduction bevel helical gear KBN  
 $i_N = 6.3$  to 18

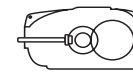

Triple reduction bevel helical gear KCN  
 $i_N = 14$  to 100

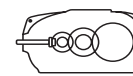

Quadruple reduction bevel helical gear KDN  
 $i_N = 100$  to 630

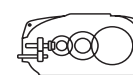

**Hollow shaft design with shrink disc Machine Shafts**



## Selection of ELECON-ET Series gear units

### 1. Determination of the type of gear

- 1.1 Establish whether helical gear or bevel helical gear  
1.2 Determine the transmission ratio

$$i_N = \frac{n_1}{n_2}$$

The type of gear is then determined

### 2. Determination of the gear size

- 2.1 Finding out gear box size

$$P_N \geq P_e \times f \quad 'f' \text{ from tables 1,2 and 4}$$

- 2.2 Cheking starting torque

$$\frac{M_k \cdot n_1}{P_N \cdot 955} \leq 2.5$$

### 3. Checking heating effects

- 3.1 Gear unit without additional cooling when

$$P_e \leq P_{G1} \times f_w$$

- 3.2 Gear unit with fan possible when

$$P_e \leq P_{G2} \times f_w$$

- 3.3 Gear unit with built-in cooling coil possible when

$$P_e \leq P_{G3} \times f_w$$

- 3.4 Gear unit with built-in cooling coil and fan possible when

$$P_e \leq P_{G4} \times f_w$$

- 3.5 Gear unit with external oil cooler necessary when

$$P_e \geq P_{G4} \times f_w$$

$i_N$  = nominal transmission ratio

$n_1$  = input speed [rpm];

$n_2$  = output speed [rpm];

$P_N$  = nominal gear box rating [kW] - see power table

$P_e$  = absorbed power of the connected machine [kW]

$f$  = service factor =  $f_1 \times f_2$

$f_w$  = factor for amb. temperatures (table 3)

$t$  = ambient temperature [ $^{\circ}$  C]

$E_D$  = running period [%], e.g.  $E_D = 80\%$

$P_{G1}$  = Thermal capacity without additional cooling at  $t=20^{\circ}$  C;  $E_D = 100$  (see power table)

$P_{G2}$  = Thermal capacity with fan

$P_{G3}$  = Thermal capacity with built-in cooling coil

$P_{G4}$  = Thermal capacity with built-in cooling coil and fan

$M_k$  = Starting torque or max. input torque [da Nm]

## Example of calculation

### Given

#### Prime mover :

electric motor,  $P_{\text{motor}} = 1000$ [kW];  $n_1 = 1500$  [rpm];  
2 fold starting torque  $M_k = 1273$  [da Nm]

#### Working machine :

Heavy rubber-belt conveyor

Power demand :  $P_e = 950$  [kW]

Speed :  $n_2 = 60$  [rpm];

Period of operation : 16 hours per day

Starts : 1 per hour

Running duration per hour :  $E_D = 100$  [%]

Ambient temperature :  $40$  [ $^{\circ}$  C]

#### Design of gear :

Bevel helical gear

### Required :

Type and size of gear box

### Design :

1. Determination of the gear box type

- 1.1 Bevel helical gear is specified

- 1.2  $i_N = \frac{n_1}{n_2} = \frac{1500}{60} \approx 25:1$

Selected : Gear box type KCN, triple reduction bevel helical gears.

2. Determination of gear box size

- 2.1 Operating factor : 'f' from tables 1 and 2 = 1.50

- 2.2 Required nominal gear box rating :

$$P_N = P_e \times f = 950 \text{ [kW]} \times 1.5 = 1425 \text{ [kW]}$$

- 2.3 From power table select KCN gear box size 560 with  $P_N = 1460$  [kW]

- 2.4  $P_N \geq P_e \times f$ , as  $1460 \text{ [kW]} \geq 950 \text{ [kW]} \times 1.5 = 1425 \text{ [kW]}$

- 2.5 Checking starting torque

$$\frac{M_k \cdot n_1}{P_N \cdot 955} \leq 2.5 = \frac{1273 \text{ [da Nm]} \cdot 1500 \text{ [rpm]}}{1460 \text{ [kW]} \cdot 955} = 1.37$$

3. Check for heating

- 3.1 From table 3

$f_w = 0.75$  for gear unit without additional cooling

$P_e \leq P_{G1} \times f_w$ , as  $950 \text{ [kW]} \leq 485 \text{ [kW]} \times 0.75 = 364 \text{ [kW]}$ , i.e., additional cooling is required.

- 3.2 From table 3

$f_w = 0.8$  for gear unit with fan cooling

$P_e \leq P_{G2} \times f_w$ , as  $950 \text{ [kW]} \leq 1160 \text{ [kW]} \times 0.8 = 928 \text{ [kW]}$ , i.e., fan cooling is not sufficient.

- 3.3 From table 3

$f_w = 0.85$  for gear unit with cooling coil

$P_e \leq P_{G3} \times f_w$ , as  $950 \text{ [kW]} \leq 685 \text{ [kW]} \times 0.85 = 582 \text{ [kW]}$  i.e., a cooling coil is not sufficient.

- 3.4 From table 3

$f_w = 0.83$  for gear unit with fan and additional cooling coil

$P_e \leq P_{G4} \times f_w$ , as  $950 \text{ [kW]} \leq 1360 \text{ [kW]} \times 0.83 = 1129 \text{ [kW]}$

- 3.5 The KCN 560 gear unit,  $i_N = 25:1$  requires fan and cooling coil.

# Operating factors

Table 1		Load parameters		
Driven machines		Driven machines		Driven machines
<b>Excavators and stackers</b>		Impeller blowers	G	-- wet
Bucket chain excavators	S*	Turbo blowers	G	-- suction
Travelling gear		Centrifugal blowers	G	Suction rollers
--- caterpillar track	S*	<b>Generators</b>		Drying cylinders
--- rail	M	Generators, under uniform load	G	<b>Pumps</b>
Bucket-wheel stackers	M*	Welding generators	***	Proportioning pumps
Bucket wheels		<b>Rubber and Plastics</b>		Piston pumps
--- clearing	S	Extruders		- U < 1:100
--- coal	S	-- rubber	S**	- U > 1:100 - 1:200
--- lime	S	-- plastics	M**	Centrifugal pumps
Cutter heads	S*	Calenders	M**	- light liquids
Slewing machines	M*	Kneading machines, rubber	S**	- viscous liquids
Suction pumps	M*	Mixers	M**	Compression pumps
Cable drums	M	Mills, rubber	M**	Plunger pumps
Winches	M	Rolling mills, rubber	S**	Sand pumps
<b>Mining, rock, earth</b>		<b>Wood-working machinery</b>		<b>Machines for the Textile Industry</b>
Concrete mixers	M	Decorating drums	S	Bobbin winding machines
Crushers	S	Planing machine	M	Printing machines
Briquetting presses	H	Saw frames	M	Dyeing machines
Rotary kilns	S**	<b>Iron and Steel Industry</b>		Tan-liquor vessels
Pneumatic sifters	M*	Foundry crane (hoisting gear)	S**	Calenders
Clay mixers	M	Converters	***	Willowing machines
<b>Chemical Industry</b>		Slag cars	G**	Drying machines
Mixers	M	Sintering belts	M**	Looms
Agitators		Crusher	S**	<b>Compressors</b>
--- pure liquids	G	Torpedo mixers	***	Rotary piston compressors
--- liquids and solids	M	Car tipper	S	- U < 1:100
--- liquids with various densities	M	<b>Cranes</b>		- U > 1:100 - 1:200
Rotary Dryer	M	Luffing gear	G*	Centrifugal compressors
Centrifuges		Travelling gear	M*	Turbo compressors
--- light	G	Hoisting gear	M*	<b>Rolling mills</b>
--- heavy	M	Slewing gear	M*	Plate tilters
<b>Petroleum Industry</b>		Winches	G	Bloom pushers
Drilling pumps	***	<b>Metal working</b>		Bloom conveying plant
Rotary Kilns	M	Folding presses	S	Wire pulls
Filter presses	M**	Plate bending machines	M**	Revolving turrets
Pipeline pumps	M**	Plate straightening presses	S	(contin. casting)
Scavenging pumps	M**	Eccentric presses	S	De-scaling crushers
<b>Conveying plants</b>		Hammers	S**	Reels
Uniform load		Planing machines	S	- strip
Bucket conveyors	G	Crank presses	S	- wire
Roasting furnace conveyors	G	Shearing machine	M**	Walking beam conveyors
Assembly line belts	G	Forging presses	S	Chain transporter
Band conveyors	G	Punching machines	S	Cooling troughs
Overhead conveyors	G	<b>Mills</b>		Traverse tractors
Chain conveyors	G	Hammer mills	H**	Pipe welding machine
Apron conveyors	G	Edge mills	H**	Pipe drawing machine
Worm conveyors	G	Ball mills	H**	Roller straightening machine
Medium and heavy load		Pendulum mills	H**	Roller gear beds
Shaft - sinking machines	S*	Impact mills	H**	--- light
Bucket conveyors	M	Tube mills	H**	--- heavy
Bucket belts	M**	Beating mills	H**	Shears
Assembly line conveyors	M	Rod mills	H**	--- plate
Conveyors winders	M**	Roller mills	H**	--- wire
Conveyors	S*	<b>Foodstuffs machines</b>		--- billet
Belt Conveyors	M	Filling machines	G	--- cropping
Chain Conveyors	M	Kneading machines	M	--- plate trimming
Goods lifts	M	Packing machines	G	Winding turret
Passenger lifts	***	Weighing machines	M	Winding tractor
Apron conveyors	M	Sugarcane crushers	M**	Continuous casting plants
Shaker conveyors	M	Sugarcane mills	S**	Shifting device
Worm conveyors	M	Sugarcane Cutters	M**	Roller adjusting device
Inclined lifts	S**	Sugar-beet Cutters	M	<b>Water recycling machine</b>
<b>Blowers, fans, ventilators</b>		<b>Paper machines</b>		Thickeners
Axial blowers	M	Couchers	S**	Gyroscopic ventilators
Rotary piston blowers	M	Glazing cylinders	S**	Mixers
Large ventilators (mining)	M	Calenders	M**	Water screws
Cooling tower fans	***	Mixers	M	Vacuum filter presses
Radial blowers	M	Presses	M	Rate/Screen drives
Induced draft fans	M	--- glue	S**	

Table 2		Service factor			f <sub>1</sub>	
Prime mover	Hours of operation/day	Prime mover Load parameter			Extra Heavy duty H	
		Uniform load G	Medium load M	Heavy load S		
Electric motor turbine	up to 3	0.80	1.00	1.50	2.0	
	over 3 to 10	1.00	1.25	1.75	2.25	
	over 10 to 24	1.25	1.50	2.00	2.5	
Piston engines 4-6 cylinder U>1:100-1:200	up to 3	1.00	1.25	1.75	2.25	
	over 3 to 10	1.25	1.50	2.00	2.5	
	over 10 to 24	1.50	1.75	2.25	2.75	
Piston engines 1-3 cylinder U<1:100	up to 3	1.25	1.50	2.00	2.5	
	over 3 to 10	1.50	1.75	2.25	2.75	
	over 10 to 24	1.75	2.00	2.50	3.0	

1) Cooling water temperature max. 20°C

Load parameters

G = Uniform load

M = Medium load

S = Heavy load

H = Extra Heavy duty

\* = Detailed calculation on request

\*\* = Only calculated for 24-hour period of operation

\*\*\* = Load parameter on request.

U = Cyclic variation

The load parameters quoted are parameters gained from experience. Calculations for driven machines not mentioned above or deviations from the norm obtainable on request.

Table 3		Factor for amb. temperatures					f <sub>w</sub>
Type of cooling	Ambient temperature	Duration of operation per hour					
		100%	80%	60%	40%	20%	
For gear boxes without additional cooling	10°C	1.12	1.34	1.57	1.79	2.05	
	20°C	1.0	1.2	1.4	1.6	1.8	
	30°C	0.88	1.06	1.23	1.41	1.58	
For gear boxes with fans	40°C	0.75	0.9	1.05	1.2	1.35	
	50°C	0.63	0.76	0.88	1.01	1.13	
	10°C	1.15	1.38	1.61	1.84	2.07	
For gear boxes with cooling coils	20°C	1.0	1.2	1.4	1.6	1.8	
	30°C	0.9	1.08	1.26	1.44	1.62	
	40°C	0.8	0.96	1.12	1.29	1.44	
For gear boxes with fans and cooling coils	50°C	0.7	0.84	0.98	1.12	1.26	
	10°C	1.1	1.32	1.54	1.76	1.98	
	20°C	1.0	1.2	1.4	1.6	1.8	
For gear boxes with fans and cooling coils	30°C	0.9	1.08	1.26	1.44	1.62	
	40°C	0.85	1.02	1.19	1.36	1.53	
	50°C	0.8	0.96	1.12	1.29	1.44	
For gear boxes with fans and cooling coils	10°C	1.12	1.34	1.57	1.79	2.05	
	20°C	1.0	1.2	1.4	1.6	1.8	
	30°C	0.92	1.1	1.29	1.47	1.66	
For gear boxes with fans and cooling coils	40°C	0.83	1.0	1.16	1.33	1.5	
	50°C	0.78	0.94	1.09	1.25	1.4	

1) Maximum cooling-water temperature 20°C

Table 4		Starting-frequency factor						f <sub>2</sub>
Starts per hour		Driven machines factor						
		1	2	3	4	5	6	
1	1	1	1	1	1	1	1	
2 to 20	1.2	1.1	1.08	1.07	1.07	1.06		
21 to 40	1.3	1.2	1.17	1.16	1.15	1.08		
41 to 80	1.5	1.4	1.25	1.23	1.18	1.10		
81 to 160	1.6	1.5	1.35	1.3	1.2	1.1		
160 to 320	2	1.8	1.7	1.6	1.5	1.4		
Over 320	2.5	2.25	2	1.9	1.8	1.75		

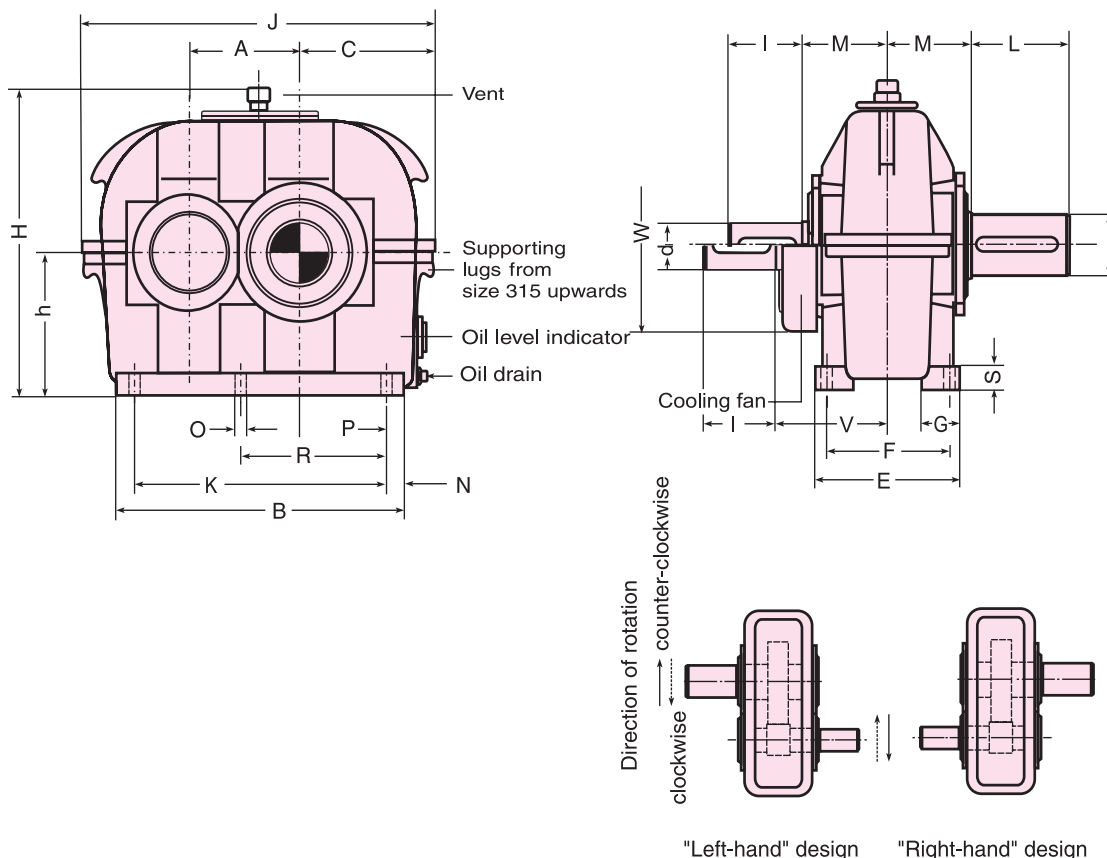

**Example of a gear unit designation :**

Gear unit SAN 200 R  
 $P_N = 330$  [kW];  $n_1 = 1500$  [rpm];  
 $n_2 = 475$  [rpm];  $i_N = 3.15:1$

Normal design, size 200  
 R: 'right - hand' design for transmission of 330 [kW]  
 at an input speed of  $n_1 = 1500$  [rpm] and a trans-  
 mission ratio of  $i_N = 3.15:1$

Size of gear unit	Input Shaft						Output shaft	Dimensions [mm]																Fan cooling		Average weight [kg]	Oil quantity [litres]		
	$i_N \leq 3.15$		$i_N > 3.15$ up to 5		$i_N > 5$			D	L	A	B	C	E	F	G	h	H	J	K	M	N	O	P	R	S			V	W
	d	l	d	l	d	l																							
80	25	60	20	50			32	80	80	205	115	140	110	45	100	240	280	175	90	15	14	60		20	185	180	18	0.7	
90	30	80	25	60			38	80	90	230	125	150	120	50	110	260	310	200	95	15	14	70		20	195	180	25	0.9	
100	35	80	30	80	20	50	45	110	100	260	135	155	125	50	125	290	340	220	100	20	14	75		25	200	180	35	1.2	
110	45	110	35	80	25	60	48	110	110	290	145	170	140	50	140	320	370	250	105	20	14	85		25	205	230	50	1.7	
125	50	110	40	110	30	80	55	110	125	330	165	185	155	55	160	355	420	290	115	20	14	100		25	215	230	65	2.2	
140	55	110	45	110	35	80	60	140	140	365	180	200	160	60	180	410	460	315	125	25	14	110		35	220	300	95	3	
160	60	140	50	110	40	110	70	140	160	410	205	230	190	65	200	450	520	350	135	30	18	120		35	230	300	120	4	
180	70	140	55	110	45	110	80	170	180	470	220	250	210	70	225	505	560	410	150	30	18	145		35	240	300	170	6.5	
200	75	140	60	140	50	110	90	170	200	520	250	270	220	75	250	550	640	450	160	35	23	155		40	260	380	225	8.5	
225	85	170	70	140	55	110	100	210	225	590	275	290	240	80	280	605	710	520	175	35	23	180		45	270	380	320	12	
250	95	170	80	170	60	140	110	210	250	650	305	325	265	90	315	665	790	570	185	40	27	195		50	295	530	415	16	
280	105	210	90	170	70	140	120	210	280	720	340	350	290	100	355	735	880	630	200	45	27	215	370	55	310	530	570	21	
315	115	210	95	170	80	170	140	250	315	805	375	390	315	110	400	815	975	705	215	50	33	240	420	60	335	650	760	30	
355	130	250	110	210	90	170	160	300	355	910	425	400	325	120	450	905	1100	810	235	50	33	280	480	65	350	650	1025	42	
400	145	250	120	210	100	210	170	300	400	1020	475	430	350	130	500	1000	1230	910	250	55	33	315	540	70	365	650	1400	58	
450	160	300	130	250	110	210	190	350	450	1145	535	475	390	140	560	1120	1385	1025	280	60	39	355	615	80	405	650	1900	80	
500	180	300	140	250	120	210	210	350	500	1275	590	510	425	150	630	1275	1535	1155	295	60	39	400	680	90	420	650	2800	105	
560	190	350	160	300	130	250	240	410	560	1425	650	550	465	160	710	1410	1700	1305	310	60	39	450	760	100	435	650	3810	140	
630	210	350	180	300	140	250	260	410	630	1600	730	570	485	170	800	1580	1910	1480	330	60	39	510	840	110	455	650	5100	190	

**Larger gear box sizes of this design on enquiry.**

Dimensions not binding. Get certified drawings for installation purpose.

Modification of dimensions reserved.

Shaft ends with keys according to DIN 6885, part 1, Shape A.  
 Shaft centering according to DIN 332, shape DS (with thread)  
 Tolerance field for shaft ends ISO fit, up to 50 mm  $\pm k 6$ ; over 50 mm  $\pm m 6$ .

Nominal transmission ratio $i_N$	Nominal speeds [rpm]; $n_1$ $n_2$		Size of gear unit																		
			80	90	100	110	125	140	160	180	200	225	250	280	315	355	400	450	500	560	630
			Nominal gear box rating $P_N$ (kW)																		
1.6	1500	940	50	74	97	120	170	230	305	390	550	740	1100*	1500*	2050*	2700*					
	1000	625	36	53	71	90	130	175	230	290	400	550	800	1100	1450	2100	2790*				
	750	470	28	41	56	70	105	140	190	240	310	455	660	900	1180	1560	2280	3450	4340		
1.8	1500	835	45	67	91	110	160	210	290	355	500	690	1000	1400*	2000*	2600*					
	1000	555	32	48	66	85	120	160	220	265	370	520	750	1020	1400	1800	2620	3860*			
	750	415	25	37	52	66	98	130	180	220	280	425	610	830	1120	1450	2140	3150	4030		
2	1500	750	38	58	79	105	150	200	270	340	480	630	950	1300	1800*	2400*					
	1000	500	27	43	57	77	110	150	200	250	350	475	700	940	1300	1680	2500	3630	4630*		
	750	375	21	34	44	60	89	120	165	210	265	390	580	770	1020	1370	1990	2970	3790	4810	
2.24	1500	670	37	51	68	95	135	180	250	310	450	600	890	1200	1650*	2200*					
	1000	445	26	36	48	68	100	135	190	235	300	450	650	900	1200	1600	2300	3360	4250*		
	750	335	20	28	37	52	82	110	155	190	240	370	530	740	970	1260	1820	2750	3480	4420	4510*
2.5	1500	600	30	47	57	78	125	170	230	290	400	550	820	1100	1500	2050*					
	1000	400	21	33	41	55	95	125	170	220	280	410	620	820	1120	1450	2100	3080	4050*		
	750	300	17	25	32	43	77	105	140	180	230	335	500	670	900	1180	1720	2520	3310	4120	4200
2.8	1500	535	27	42	48	66	115	160	210	265	370	495	750	1000	1350	1850					
	1000	360	19	30	34	46	80	120	160	200	260	375	560	750	1000	1310	1910	2890	3700		
	750	270	15	23	27	36	62	93	130	165	210	305	460	610	820	1070	1560	2360	3030	3830	3930
3.15	1500	475	23	34	47	63	91	140	190	240	330	460	680	920	1250	1650	2320	3500*	4430*		
	1000	315	16	24	33	44	62	105	140	180	235	350	510	690	920	1200	1750	2640	3330	4220	
	750	235	13	18	26	35	47	82	110	150	190	285	410	570	750	960	1430	2150	2730	3450	3570
3.55	1500	425	20	28	43	59	92	125	185	240	330	460	680	920	1240	1510	2200	3230*	4120*		
	1000	280	14	20	31	41	63	88	130	180	225	350	490	630	900	1140	1660	2430	3100	4250	
	750	210	11	16	24	31	47	67	100	150	180	275	380	550	710	930	1350	1990	2530	3300	3470
4	1500	375	16	23	35	51	75	105	160	205	310	460	640	850	1230	1350	1990	2930	3620*		
	1000	250	11	16	25	36	53	75	105	140	215	350	455	600	880	1020	1500	2200	2730	4240	
	750	187	8.5	13	19	27	40	56	81	110	170	265	355	490	670	830	1220	1800	2230	3060	3280
4.5	1500	335	14	18	31	37	54	73	140	195	265	375	540	780	1110	1240	1770	2560	3280	5170*	
	1000	220	10	13	22	26	39	52	97	140	185	255	380	560	820	940	1230	1790	2470	3850	
	750	166	7.5	10	17	20	30	40	75	105	145	195	295	430	620	770	950	1400	1970	2960	3230
5	1500	300		17	27	33	50	73	125	140	220	375	475	670	1020	1110	1660	2470	3080	4670	
	1000	200		12	19	23	36	51	86	98	145	265	340	475	710	840	1250	1750	2320	3290	
	750	150		9.5	15	18	28	40	65	77	110	200	260	360	540	690	1020	1350	1750	2540	3200
5.6	1500	270			22	30	41	68	100	130	200	310	415	560	870	1010	1520	2020	2730	3940	
	1000	180			15	21	29	48	72	90	140	210	285	405	590	760	1050	1350	1840	2700	
	750	134			12	16	22	37	54	70	105	155	215	305	440	610	790	1040	1400	2070	3000
6.3	1500	240				23	41	57	83	120	155	240	345	495	720	940	1210	1840	2160	3160	
	1000	160				16	29	41	59	84	110	170	230	350	480	700	830	1240	1450	2150	
	750	120				13	22	32	45	63	87	130	175	270	360	530	640	950	1100	1640	2500
Nominal transmission ratio $i_N$	input speeds [rpm]; $n_1$		Size of gear unit																		
			80	90	100	110	125	140	160	180	200	225	250	280	315	355	400	450	500	560	630
			Thermal capacity, $P_{G1}$ (kW), for gear boxes without cooling																		
1.6 to 2.8	1500		23	29	37	50	59	75	92	115	145	175	225	280	355	450					
	1000		21	27	34	42	54	70	87	112	136	167	218	275	350	440	540	660	820	1050	1200
3.15 to 6.3	1500		18	24	31	38	51	66	82	102	125	160	220	270	345	440	560	690			
	1000		16	20	29	33	45	62	79	94	120	151	210	260	335	425	535	650	810	1020	1180
750		14	18	22	29	40	60	78	86	115	140	200	240	320	415	525	640	790	980		
			Thermal capacity, $P_{G2}$ (kW), for gear boxes with fan cooling																		
1.6 to 2.8	1500		42	48	65	85	102	130	158	200	262	310	400	500	640	790					
	1000		35	44	55	70	85	110	132	180	225	280	325	422	560	690	860	1160	1400	1800	
750		30	40	50	62	75	98	120	165	205	260	310	390	525	630	810	1065	1310	1700	2000	
3.15 to 6.3	1500		38	42	60	75	92	120	152	190	235	300	378	475	615	785	980	1245	1560		
	1000		28	34	43	56	75	90	122	150	202	240	320	415	525	685	835	1050	1360	1750	
750		24	30	37	50	65	80	110	135	182	240	285	360	475	605	765	1000	1260	1650	1900	
			Thermal capacity, $P_{G3}$ (kW), for gear boxes with cooling coil																		
1.6 to 6.3	1500		101	121	144	175	212	245	289	335	393	470	555	650	765	920					
	1000		96	113	141	175	204	240	285	332	381	457	543	643	760	910	1070	1260	1530	1850	
750		95	111	140	168	196	231	271	328	375	450	536	640	750	890	1060	1245	1510	1780	2000	
			Thermal capacity, $P_{G4}$ (kW), for gear boxes with fan and cooling coil																		
1.6 to 6.3	1500		120	140	172	210	255	300	355	420	510	605	730	870	1050	1260					
	1000		110	130	162	200	235	280	330	400	470	570	650	790	970	1160	1390	1760	2110	2600	
750		105	125	158	190	220	265	310	390	450	550	635	760	930	1090	1340	1660	2020	2480	2800	

For power ratings indicated in **heavy type** a check of the thermal capacity is always necessary (see the example of a calculation). At normal type print this is necessary only at an ambient temperature deviating from 20°C. The nominal gear ratings  $P_N$  [kW] marked with \* require forced feed lubrication by a pump. The nominal transmission ratio is maintained with a tolerance of about ±3% Intermediate transmission ratios are possible.

**FOR MILL DUTY APPLICATIONS IT IS RECOMMENDED TO GO WITH FLS**

**ELECON-ET Series modular gear units**  
Helical gear, double reduction

**SBN**

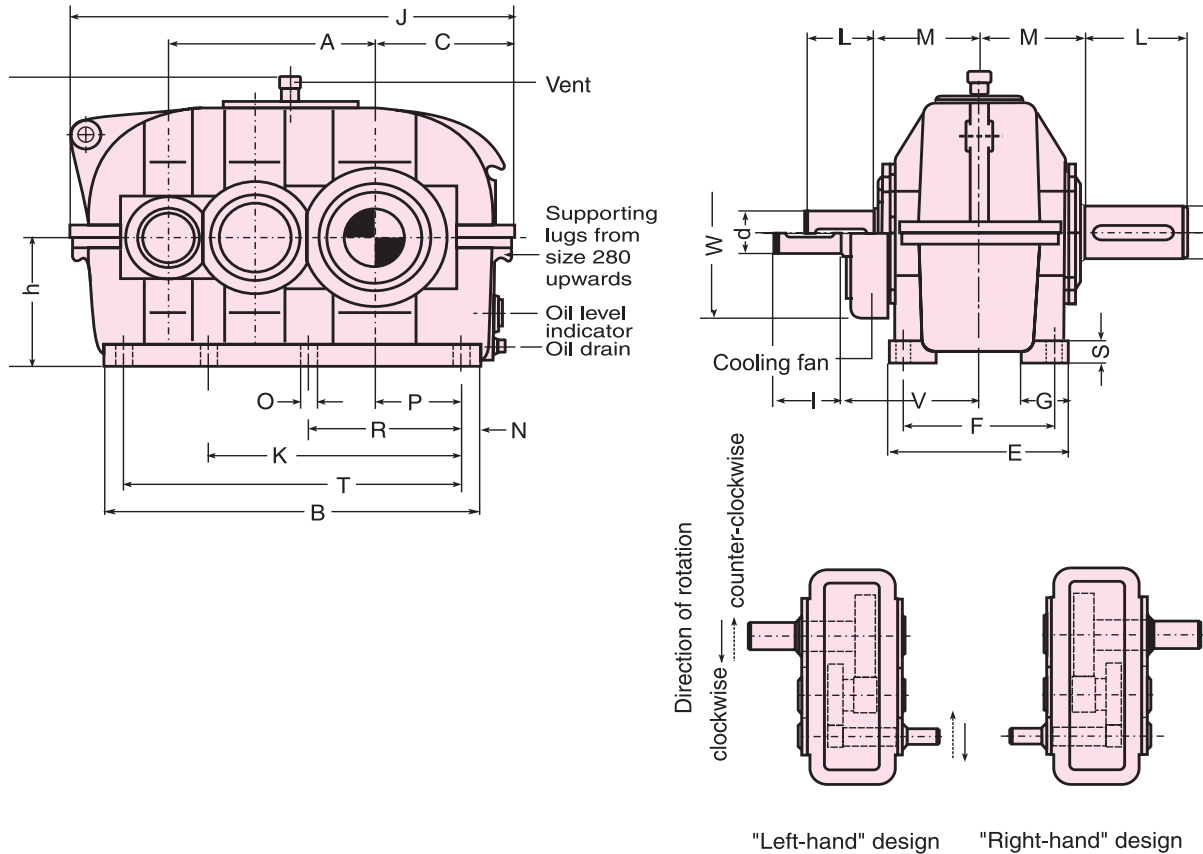

**Example of a gear unit designation :**  
Gear unit SBN 200 R  
 $P_N = 195$  [kW];  $n_1 = 1500$  rpm ;  
 $n_2 = 210$  [rpm];  $i_N = 7.1 : 1$

Normal design, size 200  
R: 'right - hand' design for transmission of 195 [kW]  
at an input speed of  $n_1 = 1500$  [rpm] and a transmission ratio of  $i_N = 7.1 : 1$

Size of gear unit	Input Shaft						Output shaft	Dimensions [mm]																Fan cooling	Average weight [kg]	Oil quantity [litres]			
	$i_N \leq 12.5$		$i_N > 12.5$ up to 20		$i_N > 20$			D	L	A	B	C	E	F	G	h	H	J	K	M	N	O	P				R	S	T
110	25	60	20	50			48	110	190	350	140	180	150	50	125	310	430		110	20	14	80	140	25	310	210	180	58	2
125	30	80	25	60			55	110	215	395	155	200	170	55	140	340	475		120	20	14	95	170	25	355	220	230	78	3
140	35	80	30	80	20	50	60	140	240	440	175	220	190	60	160	380	530		135	20	14	110	195	30	400	230	230	110	4
160	45	110	35	80	25	60	70	140	270	500	190	250	210	65	180	430	590		145	30	18	115	210	35	440	240	300	145	5
180	50	110	40	110	30	80	80	170	305	565	215	270	230	70	200	475	665		160	30	18	135	240	35	505	250	300	200	8
200	55	110	45	110	35	80	90	170	340	625	240	300	250	75	225	520	745		175	35	23	145	255	40	555	275	380	270	11
225	60	140	50	110	40	110	100	210	385	705	260	320	270	80	250	570	825		190	35	23	165	290	45	635	285	380	360	14
250	70	140	55	110	45	110	110	210	430	785	290	370	310	90	280	625	925		210	40	27	180	315	50	705	310	380	490	21
280	75	140	60	140	50	110	120	210	480	875	325	400	340	100	315	690	1035		230	45	27	200	355	55	785	340	530	675	29
315	85	170	70	140	55	110	140	250	540	975	355	450	380	110	355	785	1145		260	50	33	220	405	60	875	365	530	910	42
355	95	170	80	170	60	140	160	300	605	1085	390	480	410	120	400	865	1265		285	55	33	245	450	65	975	400	650	1230	60
400	105	210	90	170	70	140	170	300	680	1215	440	530	460	130	450	960	1425		305	55	33	280	510	70	1105	425	650	1675	85
450	115	210	95	170	80	170	190	350	765	1365	490	600	510	140	500	1065	1595	940	345	60	39	315	575	80	1245	455	650	2260	115
500	125	250	110	210	90	170	220	350	855	1525	550	650	560	150	560	1185	1785	1050	475	70	39	350	645	90	1385	555	650	3500	165
560	145	250	120	210	100	210	250	410	960	1705	610	750	640	160	630	1325	1985	1165	510	80	45	390	715	100	1545	595	650	4800	235
630	160	300	130	250	110	210	300	470	1080	1915	675	800	690	170	710	1460	2215	1305	560	80	45	445	800	110	1755	635	650	6500	330
710	180	300	140	250	120	210	340	550	1210	2150	760	900	770	190	800	1665	2480	1490	600	90	45	500	900	125	1970	670	650	9100	440
800	190	350	160	300	130	250	400	650	1360	2420	840	1000	870	200	900	1870	2770	1680	645	90	45	560	1100	140	2240	710	650	12500	600

Larger gear box sizes of this design on enquiry.

Modification of dimensions reserved.

Shaft ends with keys according to DIN 6885, part 1, Shape A.

Shaft centering according to DIN 332, shape DS (with thread)

Tolerance field for shaft ends ISO fit, up to 50 mm  $\epsilon$  k 6; over 50 mm  $\epsilon$  m 6.

**ELECON-ET Series modular gear units, hollow shaft, footmounted - Helical gear, double reduction**

**SBH**

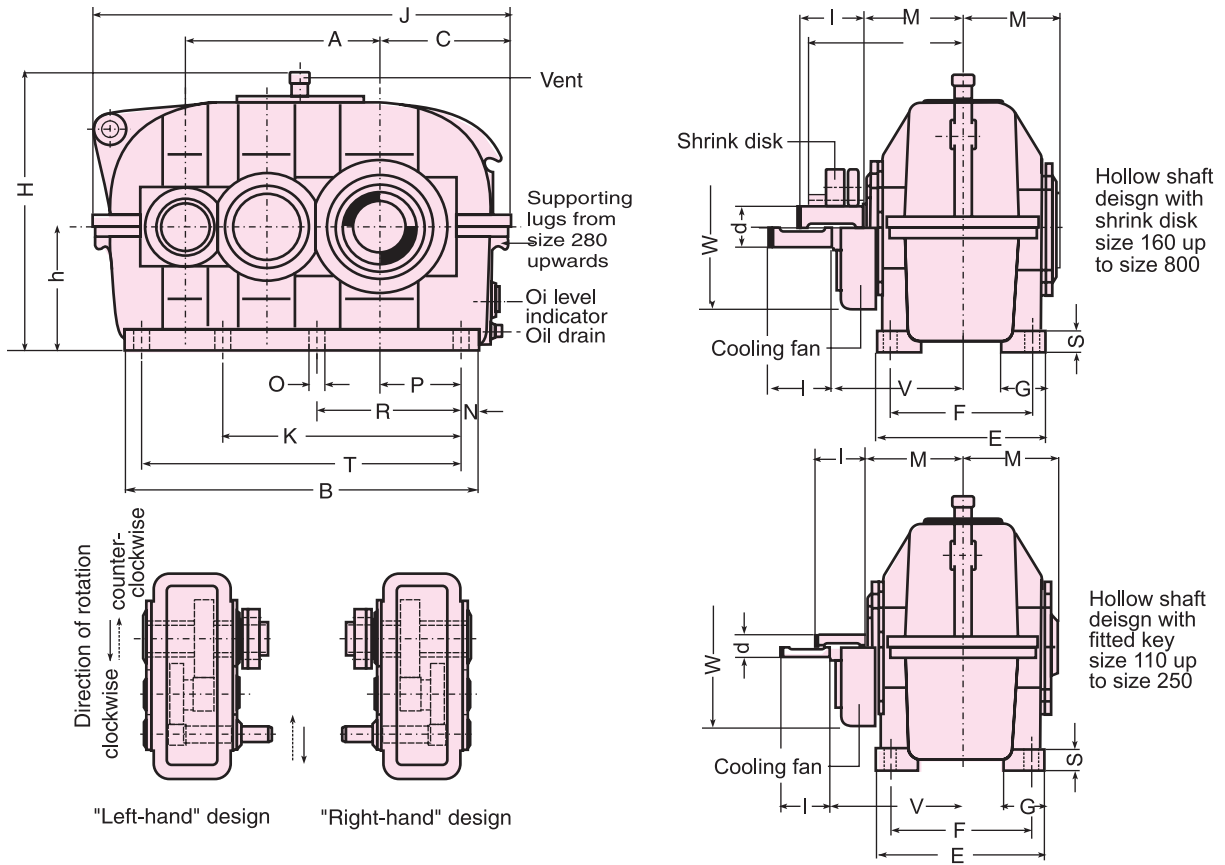

**Example of a gear unit designation :**

Gear unit SBH 200 R  
 $P_N = 195$  [kW];  $n_1 = 1500$  [rpm];  
 $n_2 = 210$  [rpm];  $i_N = 7.1 : 1$

Normal design, size 200

R: 'right - hand' design for transmission of 195 [kW] at an input speed of  $n_1 = 1500$  [rpm] and a transmission ratio of  $i_N = 7.1 : 1$

Size of gear unit	Input Shaft						Dimensions [mm]														Fan cooling		Average weight [kg]	Oil quantity [litres]				
	$i_N \leq 12.5$		$i_N > 12.5$ up to 20		$i_N > 20$		A	B	C	E	F	G	h	H	J	K	M	N	O	P	R	S			T	U	V	W
	d	l	d	l	d	l																						
110	25	60	20	50			190	350	140	180	150	50	125	310	430		110	20	14	80	140	25	310	210	180	58	2	
125	30	80	25	60			215	395	155	200	170	55	140	340	475		120	20	14	95	170	25	355	220	230	78	3	
140	35	80	30	80	20	50	240	440	175	220	190	60	160	380	530		135	20	14	110	195	30	400	230	230	110	4	
160	45	110	35	80	25	60	270	500	190	250	210	65	180	430	590		145	30	18	115	210	35	440	240	300	145	5	
180	50	110	40	110	30	80	305	565	215	270	230	70	200	475	665		160	30	18	135	240	35	505	250	300	200	8	
200	55	110	45	110	35	80	340	625	240	300	250	75	225	520	745		175	35	23	145	255	40	555	275	380	270	11	
225	60	140	50	110	40	110	385	705	260	320	270	80	250	570	825		190	35	23	165	290	45	635	295	285	380	360	14
250	70	140	55	110	45	110	430	785	290	370	310	90	280	625	925		210	40	27	180	315	50	705	325	310	380	490	21
280	75	140	60	140	50	110	480	875	325	400	340	100	315	690	1035		230	45	27	200	355	55	785	360	340	530	675	29
315	85	170	70	140	55	110	540	975	355	450	380	110	355	785	1145		260	50	33	220	405	60	875	420	365	530	910	42
355	95	170	80	170	60	140	605	1085	390	480	410	120	400	865	1265		285	55	33	245	450	65	975	450	400	650	1230	60
400	105	210	90	170	70	140	680	1215	440	530	460	130	450	960	1425		305	55	33	280	510	70	1105	490	425	650	1675	85
450	115	210	95	170	80	170	765	1365	490	600	510	140	500	1065	1595	940	345	60	39	315	575	80	1245	550	455	650	2260	115
500	125	250	110	210	90	170	855	1525	550	650	560	150	560	1185	1785	1050	475	70	39	350	645	90	1385	715	555	650	3500	165
560	145	250	120	210	100	210	960	1705	610	750	640	160	630	1325	1985	1165	510	80	45	390	715	100	1545	760	595	650	4800	235
630	160	300	130	250	110	210	1080	1915	675	800	690	170	710	1460	2215	1305	560	80	45	445	800	110	1755	840	635	650	6500	330
710	180	300	140	250	120	210	1210	2150	760	900	770	190	800	1665	2480	1490	600	90	45	500	900	125	1970	890	670	650	9100	440
800	190	350	160	300	130	250	1360	2420	840	1000	870	200	900	1870	2770	1690	645	90	45	560	1100	140	2240	955	710	650	12500	600

Larger gear box sizes of this design on enquiry.

Modification of dimensions reserved.

Shaft ends with keys according to DIN 6885, part 1, Shape A.

Shaft centering according to DIN 332, shape DS (with thread)

Tolerance field for shaft ends ISO fit, up to 50 mm  $\pm k 6$ ; over 50 mm  $\pm m 6$ .

**ELECON-ET Series modular gear units,**  
shaftmounted Helical gear, double reduction

**SBA**

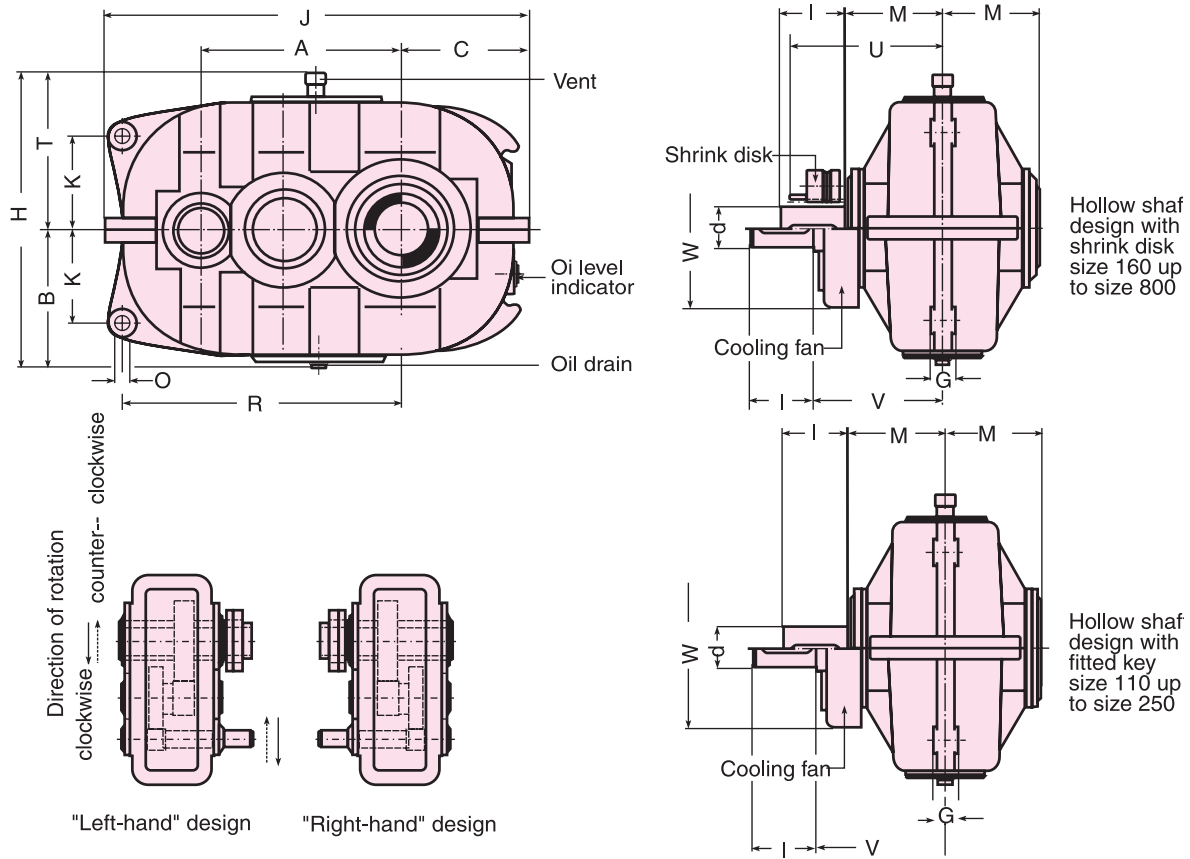

**Example of a gear unit designation :**

Gear unit SBA 200 R

$P_N = 195$  [kW];  $n_1 = 1500$  [rpm];  
 $n_2 = 210$  [rpm];  $i_N = 7.1 : 1$

Normal design, size 200

R: 'right - hand' design for transmission of 195 [kW]  
at an input speed of  $n_1 = 1500$  [rpm] and a trans-  
mission ratio of  $i_N = 7.1 : 1$

Size of gear unit	Input Shaft						Dimensions [mm]														Fan cooling		Average weight [kg]	Oil quantity [litres]
	$i_N \leq 12.5$	$i_N > 12.5$ up to 20		$i_N > 20$		A	B	C	G	H	J	K	M	O <sup>H11</sup>	R	T	U	V	W					
110	25	60	20	50			190	160	140	25	345	430	95	110	18	270	185		210	180	51	1		
125	30	80	25	60			215	175	155	28	375	475	110	120	18	300	200		220	230	68	2		
140	35	80	30	80	20	50	240	195	175	30	415	530	120	135	20	330	220		230	230	96	3		
160	45	110	35	80	25	60	270	215	190	32	465	590	135	145	20	375	250	225	240	300	127	4		
180	50	110	40	110	30	80	305	240	215	35	515	665	160	160	25	420	275	250	250	300	174	5		
200	55	110	45	110	35	80	340	260	240	45	555	745	165	175	30	475	295	275	275	380	235	6		
225	60	140	50	110	40	110	385	290	260	50	610	825	185	190	35	535	320	295	285	380	314	8		
250	70	140	55	110	45	110	430	315	290	55	660	925	210	210	40	605	345	325	310	380	428	12		
280	75	140	60	140	50	110	480	345	325	60	720	1035	235	230	45	670	375	360	340	530	595	17		
315	85	170	70	140	55	110	540	380	355	70	810	1145	265	260	50	745	430	420	365	530	800	24		
355	95	170	80	170	60	140	605	415	390	80	880	1265	295	285	55	815	465	450	400	650	1080	35		
400	105	210	90	170	70	140	680	460	440	90	970	1425	320	305	60	925	510	490	425	650	1475	50		
450	115	210	95	170	80	170	765	515	490	105	1080	1595	370	345	65	1030	565	550	455	650	1990	65		
500	125	250	110	210	90	170	855	575	550	105	1200	1785	415	475	70	1145	625	715	555	650	3120	95		
560	145	250	120	210	100	210	960	645	610	110	1340	1985	470	510	75	1275	695	760	595	650	4190	135		
630	160	300	130	250	110	210	1080	725	675	115	1500	2215	540	560	80	1425	775	840	635	650	5660	190		
710	180	300	140	250	120	210	1210	830	760	120	1695	2480	610	600	85	1590	865	890	670	650	7650	270		
800	190	350	160	300	130	250	1360	940	840	125	1910	2770	690	645	90	1780	970	955	710	650	10140	380		

Larger gear box sizes of this design on enquiry.

Modification of dimensions reserved.

Shaft ends with keys according to DIN 6885, part 1, Shape A.

Shaft centering according to DIN 332, shape DS (with thread)

Tolerance field for shaft ends ISO fit, up to 50 mm  $\pm k 6$ ; over 50 mm  $\pm m 6$ .

Power ratings

SBN/SBH/SBA

Nominal transmission ratio $i_N$	Nominal speeds [rpm]; $n_1, n_2$		Size of gear unit																	
			110	125	140	160	180	200	225	250	280	315	355	400	450	500	560	630	710	800
			Nominal gear box rating $P_N$ (kW)																	
6.3	1500	240	36	50	70	105	145	205	285	370	530	790	1060*	1450*	2020*	3740*	5060*	7020*		
	1000	160	24	34	47	71	100	145	215	280	400	560	800	1100	1520	2650	3650*	4780*	7120*	
	750	120	18	25	36	54	74	110	170	230	310	425	600	900	1200	1990	2790	3600	5420*	7700*
7.1	1500	210	36	48	66	100	140	195	280	380	490	730	990	1350*	1900*	3400*	4760*	6200*		
	1000	140	24	32	44	66	93	135	200	255	365	490	720	1000	1400	2330	3270*	4210*	6270*	
	750	105	18	24	33	50	71	100	150	210	275	370	550	790	1050	1760	2470	3170	4730	6700*
8	1500	188	32	44	62	91	125	180	255	350	450	660	920	1300	1750*	3070*	4300*	5600*		
	1000	125	22	30	41	60	85	125	180	245	335	450	680	950	1270	2120	2970	3820	5700*	
	750	94	16	22	31	46	65	92	135	190	250	340	520	710	950	1590	2230	2870	4270	6070
9	1500	167	29	40	56	83	130	185	225	320	450	580	820	1100	1500	2740*	3840*	5000*		
	1000	111	19	27	38	56	86	125	160	215	300	430	620	800	1120	1890	2640	3400	5070*	
	750	83	15	20	28	43	67	95	125	170	235	340	500	650	900	1470	2080	2750	4020	5760
10	1500	150	25	35	50	74	100	150	210	280	390	540	760	1050	1420	2540*	3560*	4590*		
	1000	100	17	24	33	49	68	95	145	195	265	360	540	750	1000	1700	2380	3060	4560*	
	750	75	13	18	25	37	50	80	110	155	210	280	420	600	800	1320	1860	2460	3600	5160
11.2	1500	134	22	32	45	66	95	140	180	250	330	480	680	900	1250	2270	3180*	4090*		
	1000	89	15	21	30	45	65	95	130	175	245	360	500	680	940	1530	2140	2750	4320	
	750	67	11	16	22	35	49	72	95	130	185	270	400	500	720	1180	1660	2200	3220	4610
12.5	1500	120	21	29	40	55	80	110	170	225	320	430	640	850	1200	2020	2830	3630*	5420*	
	1000	80	14	19	27	37	52	77	115	165	220	300	450	600	850	1390	1970	2600	3800	
	750	60	11	15	20	28	42	58	88	125	165	225	330	450	640	1050	1480	1950	2860	4090
14	1500	107	18	26	35	48	68	100	150	205	280	380	550	710	950	1790	2510	3230*	4820*	
	1000	71	12	17	24	32	46	70	105	145	195	265	400	520	710	1240	1750	2310	3380	
	750	53	9	13	18	24	35	52	78	110	145	200	290	420	560	930	1310	1730	2530	3630
16	1500	94	15	22	30	43	60	90	135	185	250	340	490	650	860	1590	2230	2870	4270*	
	1000	62	10	15	20	29	40	62	92	130	175	235	350	490	650	1100	1550	2050	3000	
	750	47	8	11	15	22	32	47	69	97	130	175	270	370	500	820	1170	1540	2250	3220
18	1500	83	13	19	27	37	55	73	120	140	220	310	430	550	740	1470	1760	2570	4020	
	1000	56	8.5	14	19	25	39	51	80	98	145	230	320	410	540	970	1230	1820	2730	
	750	41	6.5	10	15	19	30	40	62	77	110	180	250	340	440	770	950	1440	2140	3110
20	1500	75		17	24	35	49	73	110	140	210	280	410	520	700	1320	1860	2460	3600	
	1000	50		12	17	23	33	49	74	98	140	190	280	380	500	880	1240	1640	2400	
	750	38		9	12	18	25	38	58	77	110	145	230	310	400	700	990	1290	1920	2780
22.4	1500	67		21	30	41	65	99	135	185	250	390	490	660	1180	1550	2020	3110		
	1000	45		14	20	27	44	66	92	125	170	260	350	460	790	1050	1360	2100		
	750	33		11	16	21	34	52	70	98	130	200	280	370	620	790	1040	1600	2370	
Nominal transmission ratio $i_N$	input speeds [rpm]; $n_1$		Size of gear unit																	
			110	125	140	160	180	200	225	250	280	315	355	400	450	500	560	630	710	800
			Thermal capacity, $P_{G1}$ (kW), for gear boxes without cooling																	
6.3 to 14	1500		30	40	48	62	80	100	122	155	205	245	300	390	480	630	780	1000	1200	1500
	1000		26	35	46	55	72	92	120	150	190	240	290	380	470	620	770	980	1180	1470
	750		23	32	40	53	67	90	110	142	180	230	285	370	465	610	760	950	1160	1450
16 to 22.4	1500		25	34	42	56	73	94	120	147	185	240	290	380	465	610	760	970	1170	1470
	1000		22	29	36	48	61	84	108	132	175	230	280	360	460	560	740	955	1150	1450
	750		20	25	33	42	56	75	100	122	162	212	275	345	440	550	730	940	1130	1420
			Thermal capacity, $P_{G2}$ (kW), for gear boxes with fan cooling																	
6.3 to 14	1500		52	65	82	110	135	162	205	260	320	405	500	650	800	1000	1300	1600	1)	
	1000		40	50	65	85	105	145	180	220	280	370	450	580	730	920	1200	1500	1)	
	750		32	42	58	75	100	130	170	210	260	340	420	530	680	880	1150	1400	1)	1)
16 to 22.4	1500		45	58	75	95	120	155	200	250	290	390	490	630	780	950	1200	1500	1)	
	1000		34	44	55	70	95	120	160	210	270	350	440	570	700	900	1100	1400	1)	
	750		30	38	50	62	85	105	140	180	240	300	400	520	650	850	1000	1300	1)	1)
			Thermal capacity, $P_{G3}$ (kW), for gear boxes with cooling coil																	
6.3 to 22.4	1500		148	165	186	202	225	248	267	295	345	390	450	540	680	830	880	1100	1)	
	1000		136	156	181	195	217	237	260	290	340	380	440	520	660	800	870	1080	1)	
	750		121	140	162	188	207	230	250	282	330	370	425	510	645	780	860	1050	1)	1)
			Thermal capacity, $P_{G4}$ (kW), for gear boxes with fan and cooling coil																	
6.3 to 22.4	1500		170	190	220	250	280	310	350	400	460	550	650	800	1000	1200	1400	1700	1)	
	1000		150	170	200	225	250	290	320	360	430	510	600	720	920	1100	1300	1600	1)	
	750		130	150	180	210	240	270	310	350	410	480	560	670	860	1050	1250	1500	1)	1)

For power ratings indicated in **heavy type** a check of the thermal capacity is always necessary (see the example of a calculation). At normal type print this is necessary only at an ambient temperature deviating from 20°C. The nominal gear ratings  $P_N$  [kW] marked with \* require forced feed lubrication by a pump. The nominal transmission ratio is maintained with a tolerance of about ± 3% Intermediate transmission ratios are possible.

**FOR MILL DUTY APPLICATIONS IT IS RECOMMENDED TO GO WITH FLS** 1) Thermal rating on request

**ELECON-ET Series modular gear units**  
Helical gear, triple reduction

**SCN**

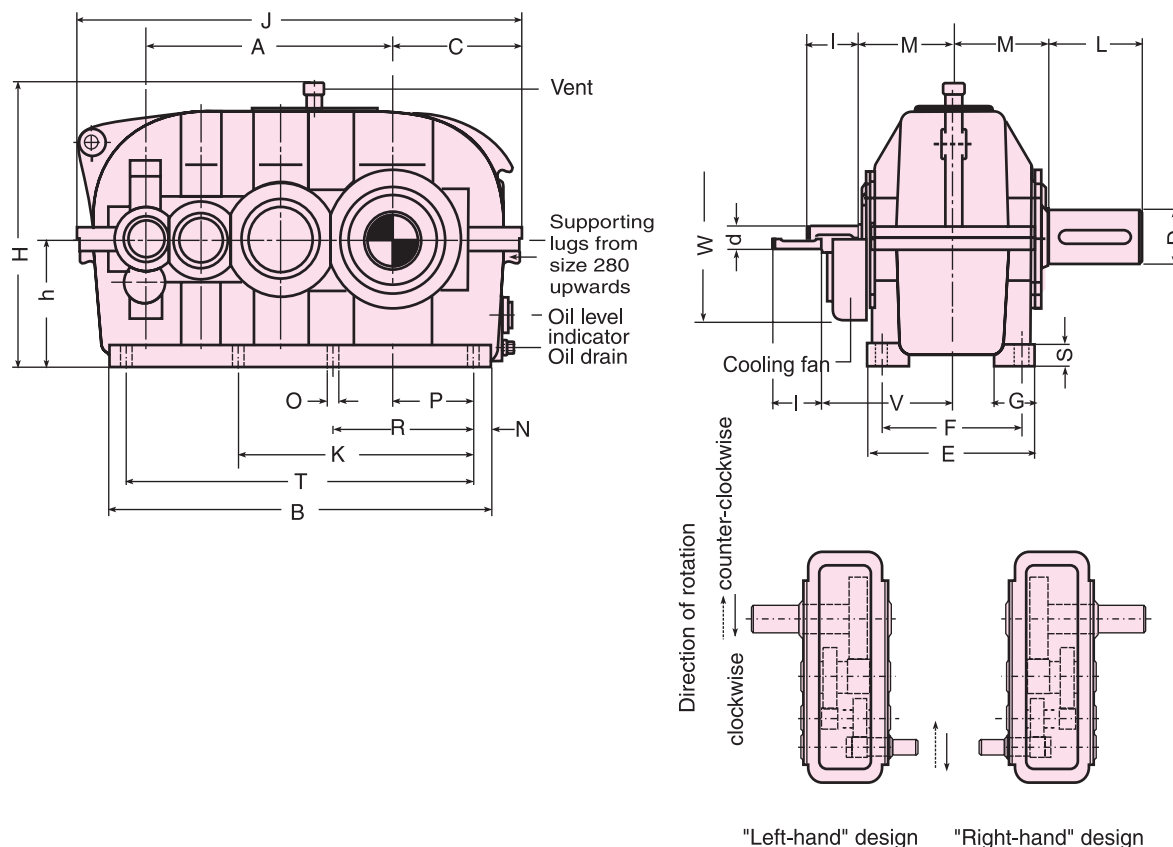

**Example of a gear unit designation :**  
Gear unit SCN 200 R  
 $P_N = 43$  [kW];  $n_1 = 1500$  rpm ;  
 $n_2 = 38$  [rpm];  $i_N = 40 : 1$

Normal design, size 200  
R: 'right - hand' design for transmission of 43 [kW]  
at an input speed of  $n_1 = 1500$  [rpm] and a transmission ratio of  $i_N = 40:1$

Size of gear unit	Input Shaft						Output shaft		Dimensions [mm]																	Fan cooling		Average weight [kg]	Oil quantity [litres]
	$i_N \leq 45$		$i_N > 45$ up to 100		$i_N > 100$																								
	d	l	d	l	d	l	D	L	A	B	C	E	F	G	h	H	J	K	M	N	O	P	R	S	T	V	W		
160	25	60	20	50			70	140	350	555	190	250	210	65	180	430	645		145	30	18	115	210	35	495	240	300	160	8
180	30	80	25	60			80	170	395	625	215	270	230	70	200	475	725		160	30	18	135	240	35	565	250	300	215	10
200	35	80	30	80	20	50	90	170	440	685	240	300	250	75	225	520	805		175	35	23	145	255	40	615	275	380	295	14
225	45	110	35	80	25	60	100	210	495	775	260	320	270	80	250	570	895		190	35	23	165	290	45	705	285	380	405	22
250	50	110	40	110	30	80	110	210	555	860	290	370	310	90	280	625	1000		210	40	27	180	315	50	780	310	380	540	28
280	55	110	45	110	35	80	120	210	620	970	325	400	340	100	315	690	1130		230	45	27	200	355	55	880	340	530	720	39
315	60	140	50	110	40	110	140	250	700	1085	355	450	380	110	355	785	1255	655	260	50	33	220	405	60	985	365	530	970	56
355	70	140	55	110	45	110	160	300	785	1220	390	480	410	120	400	865	1400	740	285	55	33	245	450	65	1110	400	650	1300	80
400	75	140	60	140	50	110	170	300	880	1355	440	530	460	130	450	960	1565	840	305	55	33	280	510	70	1245	423	650	1770	115
450	85	170	70	140	55	110	190	350	990	1520	490	600	510	140	500	1065	1750	940	345	60	39	315	575	80	1400	455	650	2350	165
500	95	170	80	170	60	140	220	350	1105	1690	550	650	560	150	560	1185	1950	1050	475	70	39	350	645	90	1550	5	650	3850	220
560	105	210	90	170	70	140	250	410	1240	1895	610	750	640	160	630	1325	2175	1165	510	80	45	390	715	100	1735	595	650	5300	310
630	115	210	95	170	80	170	300	470	1395	2145	695	800	690	170	710	1485	2485	1320	560	80	45	445	800	110	1985	635	650	7250	450
710	125	250	110	210	90	170	340	550	1565	2400	760	900	770	190	800	1665	2740	1490	600	90	45	500	900	125	2220	670	650	10100	670
800	145	250	120	210	100	210	400	650	1760	2700	840	1000	870	200	900	1870	3040	1680	645	90	45	560	1100	140	2520	710	650	14100	900

Larger gear box sizes of this design on enquiry.

Modification of dimensions reserved.

Shaft ends with keys according to DIN 6885, part 1, Shape A.

Shaft centering according to DIN 332, shape DS (with thread)

Tolerance field for shaft ends ISO fit, up to 50 mm  $\pm k 6$ ; over 50 mm  $\pm m 6$ .

**ELECON-ET Series** modular gear units, hollow shaft, footmounted - Helical gear, triple reduction

**SCH**

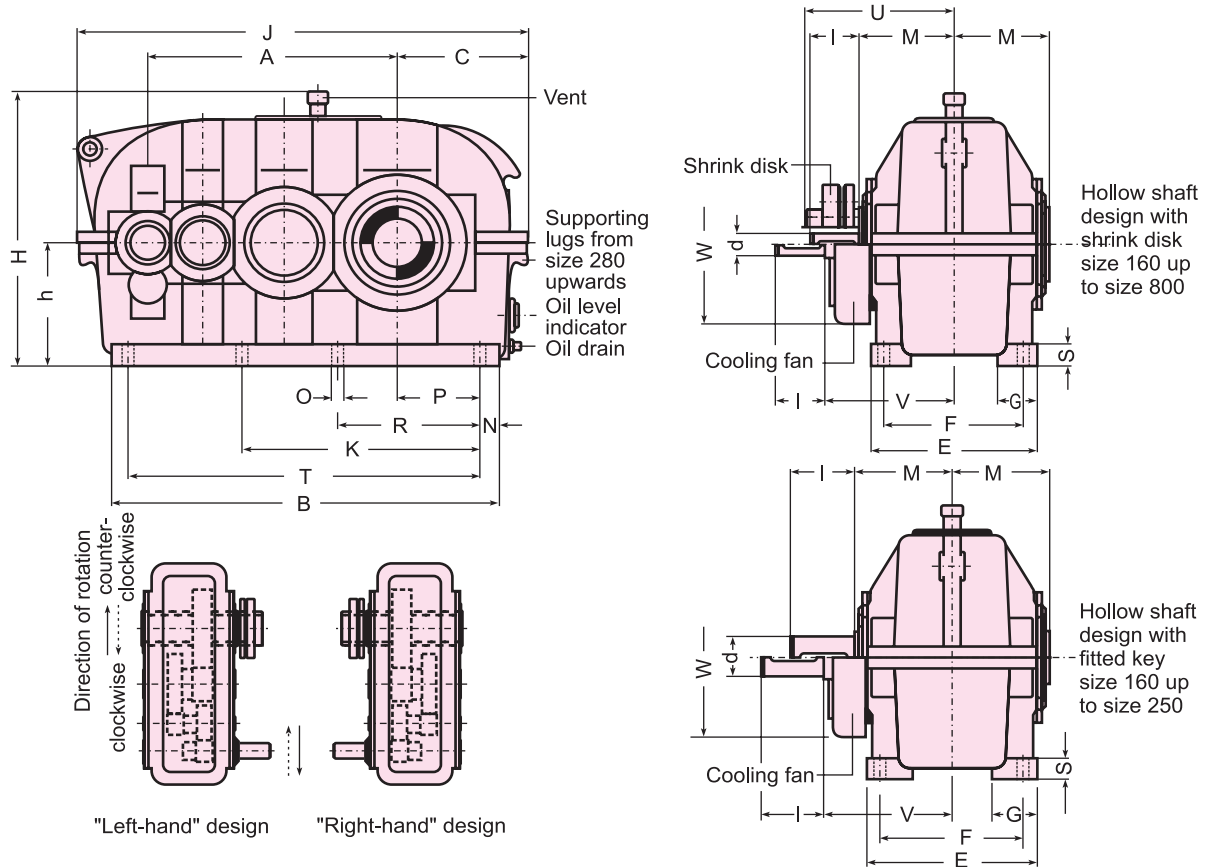

**Example of a gear unit designation :**

Gear unit SCH 200 R

$P_N = 43$  [kW];  $n_1 = 1500$  [rpm];

$n_2 = 38$  [rpm];  $i_N = 40 : 1$

Normal design, size 200

R: 'right - hand' design for transmission of 43 [kW] at an input speed of  $n_1 = 1500$  [rpm] and a transmission ratio of  $i_N = 40 : 1$

Size of gear unit	Input Shaft						Dimensions [mm]																Fan cooling		Average weight [kg]	Oil quantity [litres]		
	$i_N \leq 45$		$i_N > 45$ up to 100		$i_N > 100$		A	B	C	E	F	G	h	H	J	K	M	N	O	P	R	S	T	U			V	W
	d	l	d	l	d	l																						
160	25	60	20	50			350	555	190	250	210	65	180	430	645		145	30	18	115	210	35	495	225	240	300	160	8
180	30	80	25	60			395	625	215	270	230	70	200	475	725		160	30	18	135	240	35	565	250	250	300	215	10
200	35	80	30	80	20	50	440	685	240	300	250	75	225	520	805		175	35	23	145	255	40	615	275	275	380	295	14
225	45	110	35	80	25	60	495	775	260	320	270	80	250	570	895		190	35	23	165	290	45	705	295	285	380	405	22
250	50	110	40	110	30	80	555	860	290	370	310	90	280	625	1000		210	40	27	180	315	50	780	325	310	380	540	28
280	55	110	45	110	35	80	620	970	325	400	340	100	315	690	1130		230	45	27	200	355	55	880	360	340	530	720	39
315	60	140	50	110	40	110	700	1085	355	450	380	110	355	785	1255	655	260	50	33	220	405	60	985	420	365	530	970	56
355	70	140	55	110	45	110	785	1220	390	480	410	120	400	865	1400	740	285	55	33	245	450	65	1110	450	400	650	1300	80
400	75	140	60	140	50	110	880	1355	440	530	460	130	450	960	1565	840	305	55	33	280	510	70	1245	490	425	650	1770	115
450	85	170	70	140	55	110	990	1520	490	600	510	140	500	1065	1750	940	345	60	39	315	575	80	1400	550	455	650	2350	165
500	95	170	80	170	60	140	1105	1690	550	650	560	150	560	1185	1950	1050	475	70	39	350	645	90	1550	715	555	650	3850	220
560	105	210	90	170	70	140	1240	1895	610	750	640	160	630	1325	2175	1165	510	80	45	390	715	100	1735	760	595	650	5300	310
630	115	210	95	170	80	170	1395	2145	695	800	690	170	710	1485	2485	1320	560	80	45	445	800	110	1985	840	635	650	7250	450
710	125	250	110	210	90	170	1565	2400	760	800	770	190	800	1665	2740	1490	600	90	45	500	900	125	2220	890	670	650	10100	670
800	145	250	120	210	100	210	1760	2700	840	1000	870	200	900	1870	3040	1680	645	90	45	560	1100	140	2520	955	710	650	14100	900

Larger gear box sizes of this design on enquiry.

Modification of dimensions reserved.

Shaft ends with keys according to DIN 6885, part 1, Shape A.

Shaft centering according to DIN 332, shape DS (with thread)

Tolerance field for shaft ends ISO fit, up to 50 mm  $\pm k 6$ ; over 50 mm  $\pm m 6$ .

**ELECON-ET Series modular gear units, shaft mounted**  
Helical gear, triple reduction

**SCA**

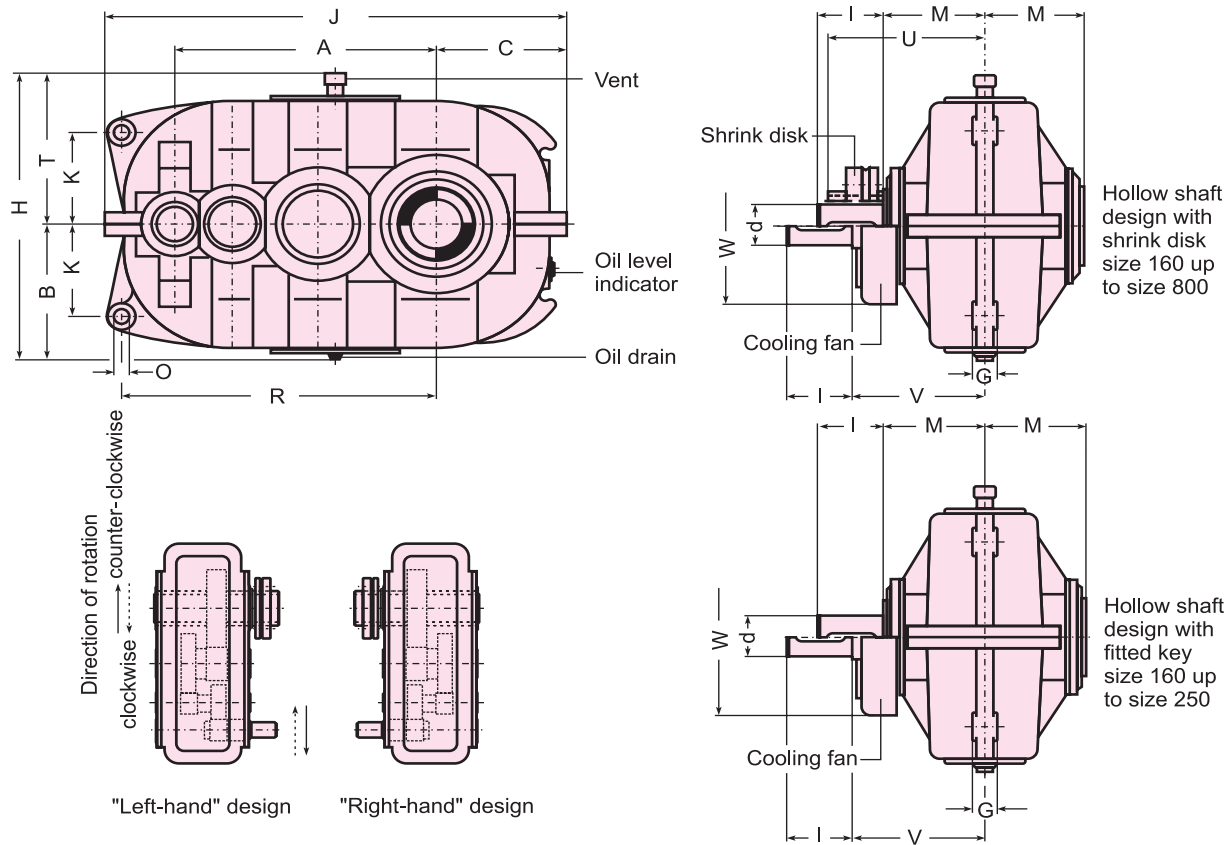

**Example of a gear unit designation :**

Gear unit SCA 200 R

$P_N = 43$  [kW];  $n_1 = 1500$  [rpm];

$n_2 = 38$  [rpm];  $i_N = 40 : 1$

Normal design, size 200

R: 'right - hand' design for transmission of 43 [kW] at an input speed of  $n_1 = 1500$  [rpm] and a transmission ratio of  $i_N = 40 : 1$

Size of gear unit	Input Shaft						Dimensions [mm]														Fan cooling	Average weight [kg]	Oil quantity [litres]
	$i_N \leq 45$		$i_N > 45$ up to 100		$i_N > 100$		A	B	C	G	H	J	K	M	O <sup>H11</sup>	R	T	U	V	W			
	d	l	d	l	d	l																	
160	25	60	20	50			350	215	190	32	465	645	135	145	20	430	250	225	240	300	141	5	
180	30	80	25	60			395	240	215	35	515	725	160	160	25	470	275	250	250	300	188	7	
200	35	80	30	80	20	50	440	260	240	45	555	805	165	175	30	535	295	275	275	380	257	9	
225	45	110	35	80	25	60	495	290	260	50	610	895	185	190	35	600	320	295	285	380	345	11	
250	50	110	40	110	30	80	555	315	290	55	660	990	210	210	40	670	345	325	310	380	460	17	
280	55	110	45	110	35	80	620	345	325	60	720	1130	235	230	45	755	375	360	340	530	610	23	
315	60	140	50	110	40	110	700	380	355	70	810	1255	265	260	50	855	430	420	365	530	820	36	
355	70	140	55	110	45	110	785	415	390	80	880	1400	295	285	55	950	465	450	400	650	1100	50	
400	75	140	60	140	50	110	880	460	440	90	970	1565	320	305	60	1065	510	490	425	650	1520	70	
450	85	170	70	140	55	110	990	515	490	105	1080	1750	370	345	65	1185	565	550	455	650	2000	100	
500	95	170	80	170	60	140	1105	575	550	105	1200	1950	415	475	70	1310	625	715	555	650	3210	130	
560	105	210	90	170	70	140	1240	645	610	110	1340	2175	470	510	75	1465	695	760	595	650	4420	200	
630	115	210	95	170	80	170	1395	725	695	115	1500	2485	540	560	80	1655	775	840	635	650	6050	280	
710	125	250	110	210	90	170	1565	830	760	120	1695	2740	610	600	85	1860	865	890	670	650	8080	390	
800	145	250	120	210	100	210	1760	940	840	125	1910	3040	690	645	90	2080	970	955	710	650	10870	540	

Larger gear box sizes of this design on enquiry.

Modification of dimensions reserved.

Shaft ends with keys according to DIN 6885, part 1, Shape A.

Shaft centering according to DIN 332, shape DS (with thread)

Tolerance field for shaft ends ISO fit, up to 50 mm  $\pm k 6$ ; over 50 mm  $\pm m 6$ .

Power ratings

SCN/SCH/SCA

Nominal transmission ratio $i_N$	Nominal speeds [rpm]; $n_1, n_2$		Size of gear unit														
			160	180	200	225	250	280	315	355	400	450	500	560	630	710	800
			Nominal gear box rating $P_N$ (kW)														
14	1500	107	50	70	105	140	200	280	380	500	660	930	1810*	2540*	3270*	4880*	
	1000	71	34	47	73	95	135	190	270	390	500	700	1250	1770	2340	3420*	4900*
	750	53	26	36	55	74	105	150	215	300	390	580	940	1330	1760	2580	3700
16	1500	94	46	65	95	130	180	260	350	460	600	860	1610*	2260*	2910*	4330*	
	1000	62	32	44	66	88	120	170	250	350	460	640	1120	1580	2090	3060*	4390*
	750	47	24	33	50	68	95	135	200	270	360	530	830	1180	1560	2280	3270
18	1500	83	42	62	85	120	160	230	320	420	550	800	1490*	2110*	2790*	4080*	
	1000	56	30	42	60	80	105	150	220	320	420	590	1000	1410	1860	2720*	3900*
	750	41	22	32	45	62	85	120	170	250	330	480	780	1110	1460	2170	3140
20	1500	75	39	59	73	105	145	205	295	385	500	740	1320*	1860*	2460*	3600*	
	1000	50	27	39	54	70	98	140	200	290	380	550	880	1240	1640	2400*	3440*
	750	38	20	30	43	55	77	110	160	240	305	445	690	990	1290	1920	2770
22.4	1500	67	35	52	66	93	130	185	270	350	480	700	1170*	1640*	2170*	3180*	
	1000	45	24	35	50	65	91	130	190	265	345	520	780	1100	1450	2120	3040*
	750	33	18	26	38	49	69	96	140	215	275	400	620	880	1140	1710	2460
25	1500	60	30	44	62	83	115	160	235	330	450	660	1030*	1460*	1930*	2820*	
	1000	40	20	30	42	57	80	110	165	255	315	460	730	1040	1350	2010	2900*
	750	30	15	22	31	43	60	85	125	195	240	350	550	780	1010	1510	2180
28	1500	54	27	40	56	75	105	145	215	310	405	590	910*	1290*	1700*	2440*	
	1000	36	18	27	38	52	72	100	150	230	285	420	640	910	1190	1770	2550*
	750	27	14	20	28	39	54	77	115	165	215	315	490	690	890	1330	1920
31.5	1500	48	24	33	48	69	95	130	200	290	385	560	820*	1170*	1540*	2260*	
	1000	32	16	22	33	46	63	87	130	200	255	370	580	820	1070	1600	2310*
	750	24	13	17	25	34	49	65	100	150	190	280	440	620	810	1200	1740
35.5	1500	42	22	32	46	62	87	120	180	280	345	500	770	1100*	1430*	2120*	
	1000	28	15	22	30	41	58	82	120	185	230	340	510	720	950	1410	2030*
	750	21	11	16	23	31	43	61	90	140	175	250	385	550	710	1060	1530
40	1500	38	20	30	43	56	78	110	160	240	310	450	700	990	1290	1920*	
	1000	25	14	21	28	37	52	72	105	165	205	300	465	660	860	1280	2770*
	750	19	10	15	22	29	41	56	82	125	155	230	350	495	640	960	1850
45	1500	33.5	17	26	36	50	69	97	145	220	275	400	620	880	1150*	1710*	
	1000	22	12	17	25	33	46	64	95	150	180	265	455	640	760	1140	2480*
	750	16.6	8.5	13	18	26	36	50	74	115	140	205	320	455	600	880	1650
50	1500	30	15	23	32	44	62	87	130	200	245	360	550	780	1030	1540*	
	1000	20	11	15	22	31	43	60	87	135	165	240	365	520	690	1020	2220*
	750	15	8	12	16	23	32	44	65	100	120	180	290	410	540	780	1480
56	1500	27	14	20	28	39	55	77	115	175	220	320	500	700	920	1370	
	1000	18	9.5	14	19	27	38	53	77	120	145	215	340	485	640	930	1980*
	750	13.4	7	10	15	21	28	40	59	91	110	165	255	360	475	690	1330
63	1500	24	11	17	23	35	45	63	100	150	195	285	440	630	810	1220	
	1000	16	7.5	11	16	24	30	43	69	105	130	190	300	430	560	820	1760
	750	12	6	8.5	12	18	23	32	52	78	98	145	230	325	430	630	1180
71	1500	21	9.5	15	21	31	40	56	90	135	175	250	395	560	730	1090	
	1000	14	6.5	10	14	22	27	39	61	92	115	170	270	380	500	730	1570
	750	10.5	5	7.5	11	16	20	29	46	69	86	125	200	285	380	550	1050
80	1500	18.8	8.5	14	19	29	36	51	82	120	155	230	350	495	640	960	
	1000	12.5	6	9	13	19	24	34	54	82	100	150	240	340	450	650	1390
	750	9.4	4.5	7	10	14	19	27	40	63	76	110	180	255	340	495	940
90	1500	16.7	8	12	17	26	32	46	74	110	140	205	320	455	600	880	
	1000	11.1	5.5	8	11	17	22	31	49	74	92	135	210	300	395	570	1260
	750	8.3	4	6.5	9	13	17	24	37	57	69	100	160	225	295	430	820
100	1500	15		9.5	16	24	30	44	60	95	130	175	290	410	540	780	
	1000	10		6.5	11	16	21	30	40	63	86	115	190	270	360	520	1130
	750	7.5		5	8	12	16	22	30	47	65	87	145	205	270	395	750
112	1500	13.4		15	21	29	40	53	84	115	155	255	360	475	690	990	
	1000	8.9		10	14	19	27	36	57	78	105	170	245	325	470	670	990
	750	6.7		7.5	11	15	20	27	43	58	78	130	185	245	355	510	990
Nominal transmission ratio $i_N$	input speeds [rpm]; $n_1$	Size of gear unit															
		160	180	200	225	250	280	315	355	400	450	500	560	630	710	800	
Thermal capacity, $P_{G1}$ (kW), for gear boxes without cooling																	
14 to 35.5	1500	42	53	65	90	108	132	172	212	265	335	405	510	650	790	1010	
	1000	39	48	60	80	98	125	168	202	255	330	400	490	630	760	990	
	750	33	44	54	75	90	118	152	195	242	312	388	485	620	750	970	
40 to 112	1500	36	48	60	80	97	122	165	202	255	330	395	495	630	770	990	
	1000	32	44	55	70	88	112	155	192	243	310	375	475	605	740	960	
	750	30	40	50	65	80	100	135	172	222	295	368	468	595	720	940	
Thermal capacity, $P_{G2}$ (kW), for gear boxes with fan cooling																	
14 to 35.5	1500	75	90	110	140	170	220	270	340	420	520	640	800	1050	1)	1)	
	1000	65	83	100	130	160	205	250	320	380	492	590	750	1002	1)	1)	
	750	61	78	95	125	152	196	240	305	362	470	560	710	960	1)	1)	
40 to 112	1500	72	88	106	138	162	205	260	324	387	500	590	755	1000	1)	1)	
	1000	63	80	95	128	153	195	245	305	360	466	552	700	942	1)	1)	
	750	58	75	90	120	140	180	232	290	342	445	522	670	900	1)	1)	
Thermal capacity, $P_{G3}$ (kW), for gear boxes with cooling coil																	
14 to 112	1500	100	120	140	170	200	250	288	360	430	545	640	750	850	1)	1)	
	1000	96	115	132	160	195	245	280	348	425	535	615	720	820	1)	1)	
	750	92	110	126	150	190	240	272	340	420	515	605	715	805	1)	1)	
Thermal capacity, $P_{G4}$ (kW), for gear boxes with fan and cooling coil																	
14 to 112	1500	133	157	185	220	262	338	386	488	585	730	875	1040	1250	1)	1)	
	1000	122	150	172	210	257	325	362	466	550	697	805	980	1192	1)	1)	
	750	120	144	167	200	252	318	360	450	540	673	777	940	1145	1)	1)	

For power ratings indicated in **heavy type** a check of the thermal capacity is always necessary (see the example of a calculation). At normal type print this is necessary only at an ambient temperature deviating from 20°C. The nominal gear ratings  $P_N$  [kW] marked with \* require forced feed lubrication by a pump. The nominal transmission ratio is maintained with a tolerance of about ± 3%. Intermediate transmission ratios are possible.

FOR MILL DUTY APPLICATIONS IT IS RECOMMENDED TO GO WITH FLS 1) Thermal ratings on request

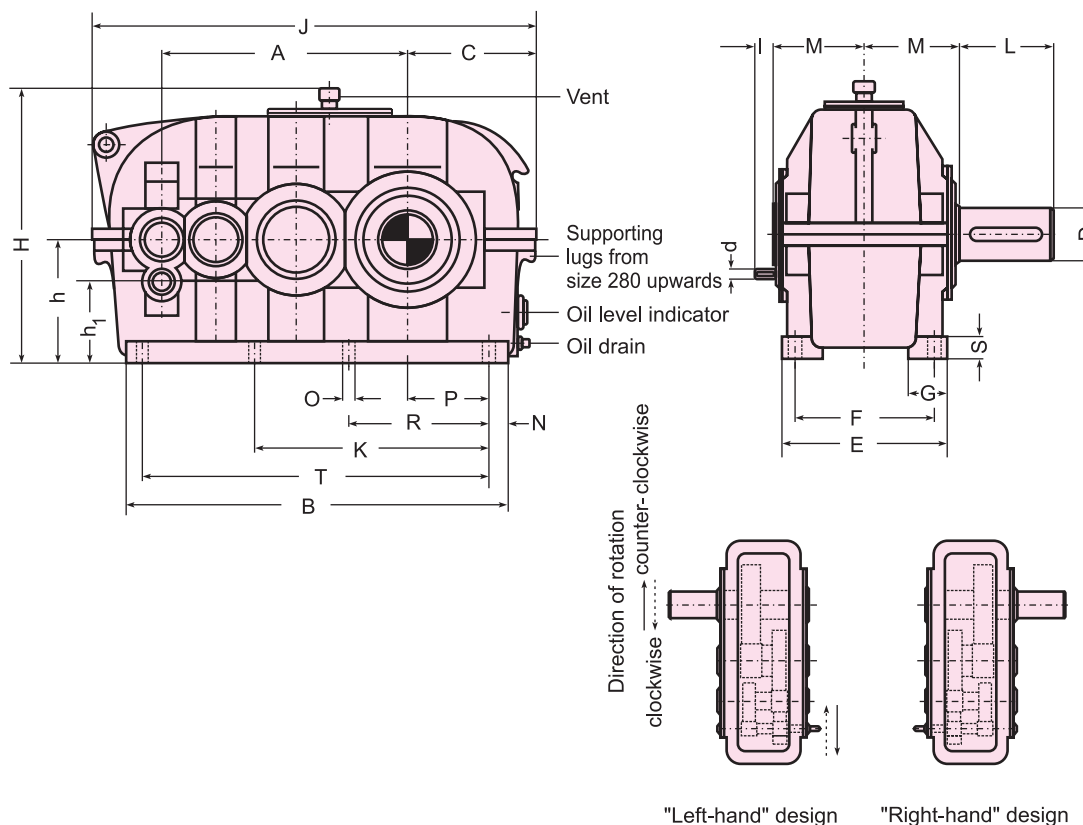

**Example of a gear unit designation :**

Gear unit SDN 280 R  
 $P_N = 22$  [kW];  $n_1 = 1500$  rpm ;  
 $n_2 = 7.5$  [rpm];  $i_N = 200 : 1$

Normal design, size 280  
 R: 'right - hand' design for transmission of 22 [kW]  
 at an input speed of  $n_1 = 1500$  [rpm] and a transmission ratio of  $i_N = 200 : 1$

Size of gear unit	Input Shaft				Output shaft		Dimensions [mm]																Average weight [kg]	Oil quantity [litres]			
	$i_N \leq 500$		$i_N > 500$		D	L	A	B	C	E	F	G	h	$h_1$	H	J	K	M	N	O	P	R			S	T	
	d	l	d	l																							
225	18	40			100	210	495	775	260	320	270	80	250	170	570	895		190	35	23	165	290	45	705	405	22	
250	22	50			110	210	555	860	290	370	310	90	280	190	625	1000		210	40	27	180	315	50	780	540	28	
280	25	60	20	50	120	210	620	970	325	400	340	100	315	215	690	1130		230	45	27	200	355	55	880	720	39	
315	30	80	25	60	140	250	700	1085	355	450	380	110	355	245	785	1255		655	260	50	33	220	405	60	985	970	56
355	40	110	30	80	160	300	785	1220	390	480	410	120	400	275	865	1400		740	285	55	33	245	450	65	1110	1300	80
400	45	110	35	80	170	300	880	1355	440	530	460	130	450	310	960	1565		840	305	55	33	280	510	70	1245	1770	115
450	50	110	40	110	190	350	990	1520	490	600	510	140	500	340	1065	1750		940	345	60	39	315	575	80	1400	2350	165
500	55	110	45	110	220	350	1105	1690	550	650	560	150	560	380	1185	1950		1050	475	70	39	350	645	90	1550	3850	220
560	60	140	50	110	250	410	1240	1895	610	750	640	160	630	430	1325	2175		1165	510	80	45	390	715	100	1735	5300	310
630	70	140	55	110	300	470	1395	2145	695	800	690	170	710	485	1485	2485		1320	560	80	45	445	800	110	1985	7250	450
710	75	140	60	140	340	550	1565	2400	760	900	770	190	800	550	1665	2740		1490	600	90	45	500	900	125	2220	10100	670
800	85	170	70	140	400	650	1760	2700	840	1000	870	200	900	620	1870	3040		1680	645	90	45	560	1100	140	2520	14100	900

Larger gear box sizes of this design on enquiry.

Modification of dimensions reserved.

Shaft ends with keys according to DIN 6885, part 1, Shape A.

Shaft centering according to DIN 332, shape DS (with thread)

Tolerance field for shaft ends ISO fit, up to 50 mm  $\epsilon$  k 6; over 50 mm  $\epsilon$  m 6.

**ELECON-ET Series** modular gear units, hollow shaft, footmounted - Helical gear, quadruple reduction

**SDH**

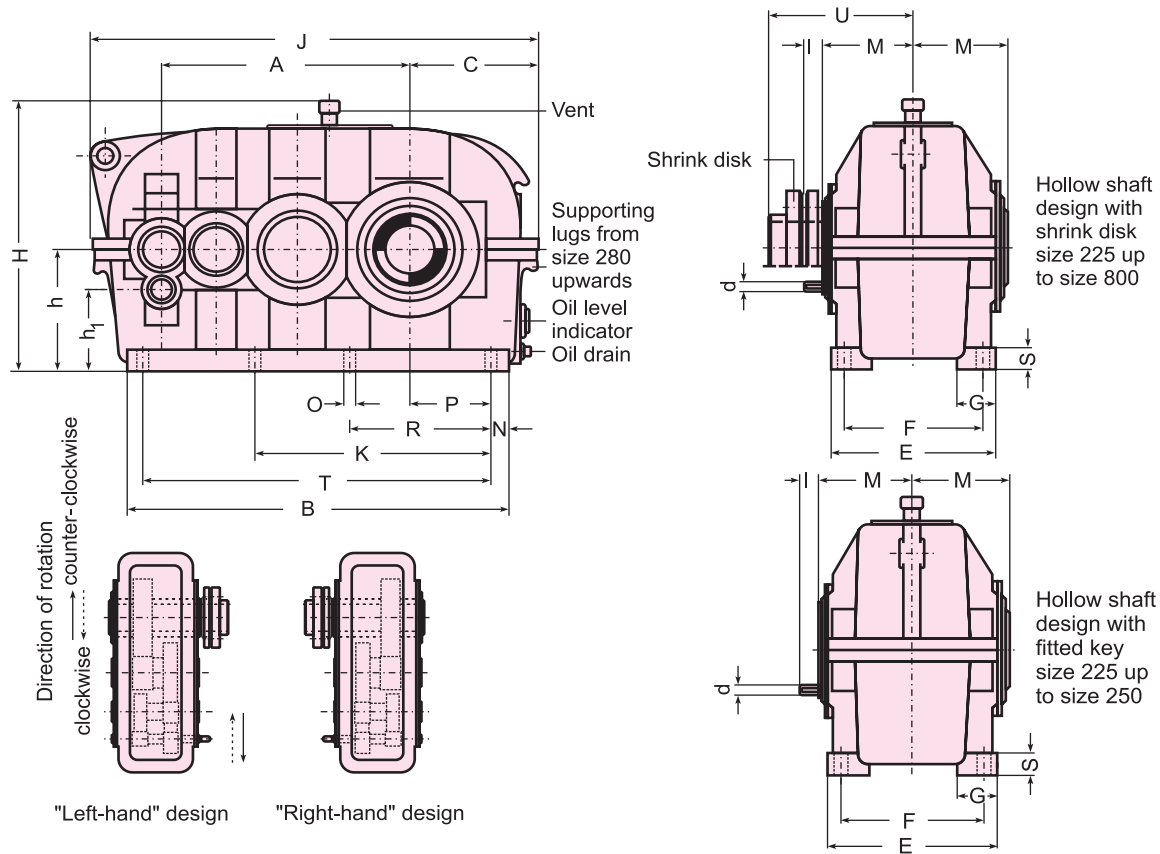

**Example of a gear unit design :**

Gear unit SDH 280 R  
 $P_N = 22$  [kW];  $n_1 = 1500$  rpm ;  
 $n_2 = 7.5$  [rpm];  $i_N = 200 : 1$

Normal design, size 280

R: 'right - hand' design for transmission of 22 [kW] at an input speed of  $n_1 = 1500$  [rpm] and a transmission ratio of  $i_N = 200 : 1$

Size of gear unit	Input Shaft				Dimensions [mm]																	Average weight [kg]	Oil quantity [litres]		
	$i_N \leq 500$		$i_N > 500$		A	B	C	E	F	G	h	$h_1$	H	J	K	M	N	O	P	R	S			T	U
	d	l	d	l																					
225	18	40			495	775	260	320	270	80	250	170	570	895		190	35	23	165	290	45	705	295	405	22
250	22	50			555	860	290	370	310	90	280	190	625	1000		210	40	27	180	315	50	780	325	540	28
280	25	60	20	50	620	970	325	400	340	100	315	215	690	1130		230	45	27	200	355	55	880	360	720	39
315	30	80	25	60	700	1085	355	450	380	110	355	245	785	1255	655	260	50	33	220	405	60	985	420	970	56
355	40	110	30	80	785	1220	390	480	410	120	400	275	865	1440	740	285	55	33	245	450	65	1110	450	1300	80
400	45	110	35	80	880	1355	440	530	460	130	450	310	960	1565	840	305	55	33	280	510	70	1245	490	1770	115
450	50	110	40	110	990	1520	490	600	510	140	500	340	1065	1750	940	345	60	39	315	575	80	1400	550	2350	165
500	55	110	45	110	1105	1690	550	650	560	150	560	380	1185	1950	1050	475	70	39	350	645	90	1550	715	3850	220
560	60	140	50	110	1240	1895	610	750	640	160	630	430	1325	2175	1165	510	80	45	390	715	100	1735	760	5300	310
630	70	140	55	110	1395	2145	695	800	690	170	710	485	1485	2485	1320	560	80	45	445	800	110	1985	840	7250	450
710	75	140	60	140	1565	2400	760	900	770	190	800	550	1665	2740	1490	600	90	45	500	900	125	2220	890	10100	670
800	85	170	70	140	1760	2700	840	1000	870	200	900	620	1870	3040	1680	645	90	45	560	1100	140	2520	955	14100	900

Larger gear box sizes of this design on enquiry.

Modification of dimensions reserved.

Shaft ends with keys according to DIN 6885, part 1, Shape A.

Shaft centering according to DIN 332, shape DS (with thread)

Tolerance field for shaft ends ISO fit, up to 50 mm  $\pm k 6$ ; over 50 mm  $\pm m 6$ .

**ELECON-ET Series** modular gear units, shaftmounted  
Helical gear, quadruple reduction

**SDA**

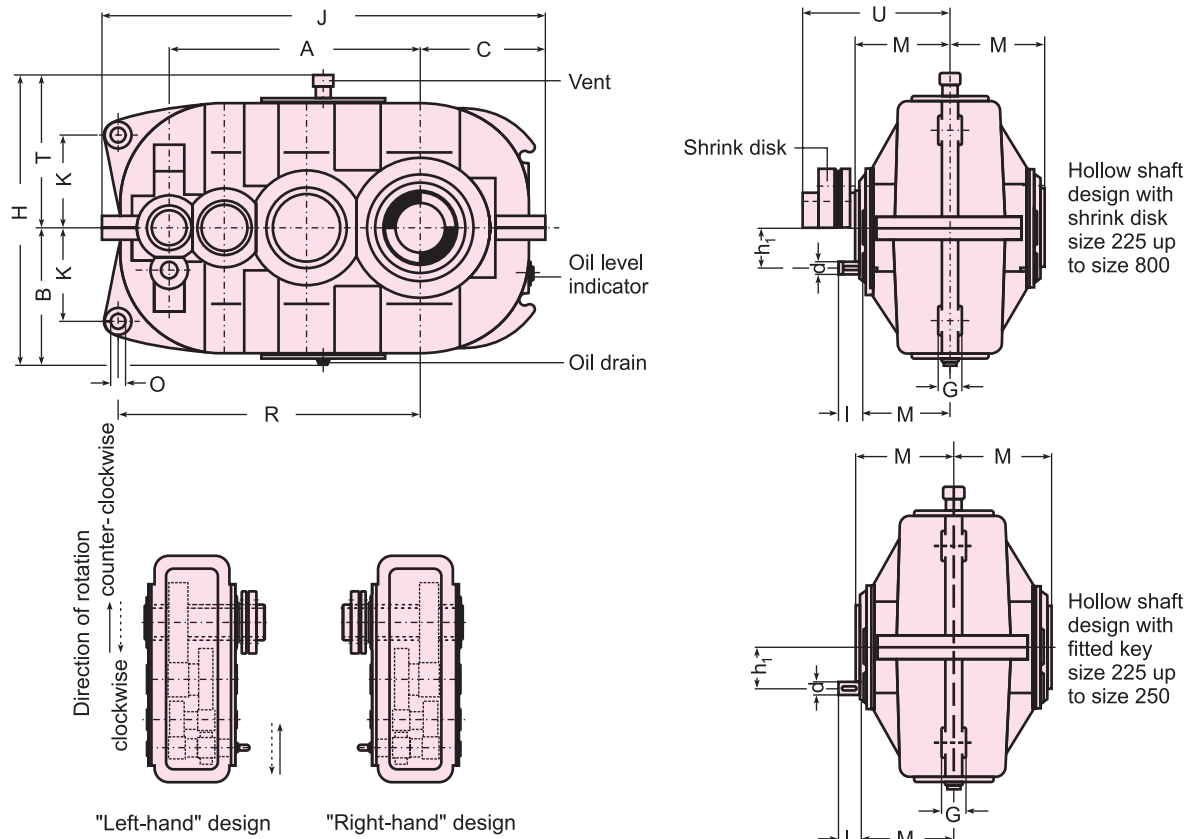

**Example of a gear unit design :**

Gear unit SDA 280 R  
 $P_N = 22$  [kW];  $n_1 = 1500$  rpm ;  
 $n_2 = 7.5$  [rpm];  $i_N = 200 : 1$

Normal design, size 280

R: 'right - hand' design for transmission of 22 [kW]  
 at an input speed of  $n_1 = 1500$  [rpm] and a transmission ratio of  $i_N = 200 : 1$

Size of gear unit	Input Shaft				Dimensions [mm]													Average weight [kg]	Oil quantity [litres]
	$i_N \leq 500$		$i_N > 500$		A	B	C	G	h1	H	J	K	M	O <sup>H11</sup>	R	T	U		
	d	I	d	I															
225	18	40			495	290	260	50	80	610	895	185	190	35	600	320	295	245	11
250	22	50			555	315	290	55	90	660	1000	210	210	40	670	345	325	460	17
280	25	60	20	50	620	345	325	60	100	720	1120	235	230	45	755	375	360	610	23
315	30	80	25	60	700	380	355	70	110	810	1255	265	260	50	855	430	420	820	36
355	40	110	30	80	785	415	390	80	125	880	1440	295	285	55	950	465	450	1100	50
400	45	110	35	80	880	460	440	90	140	970	1565	320	305	60	1065	510	490	1520	70
450	50	110	40	110	990	515	490	105	160	1080	1750	370	345	65	1185	565	550	2000	100
500	55	110	45	110	1105	575	550	105	180	1200	1950	415	475	70	1310	625	715	3210	130
560	60	140	50	110	1240	645	610	110	200	1340	2175	470	510	75	1465	695	760	4420	200
630	70	140	55	110	1395	725	695	115	225	1500	2485	540	560	80	1655	775	840	6050	280
710	75	140	60	140	1565	830	760	120	250	1695	2740	610	600	85	1885	865	890	8160	390
800	85	170	70	140	1760	940	840	125	280	1910	3040	690	645	90	2080	970	955	10870	540

Larger gear box sizes of this design on enquiry.

Modification of dimensions reserved.

Shaft ends with keys according to DIN 6885, part 1, Shape A.

Shaft centering according to DIN 332, shape DS (with thread)

Tolerance field for shaft ends ISO fit, up to 50 mm  $\pm k 6$ ; over 50 mm  $\pm m 6$ .

Power ratings

SDN/SDH/SDA

Nominal transmission ratio $i_N$	Nominal speeds [rpm]; $n_1$ $n_2$		Size of gear unit											
			225	250	280	315	355	400	450	500	560	630	710	800
			Nominal gear box rating $P_N$ (kW)											
112	1500	13.4	20	29	40	59	91	110	160	255	360	480	690	990
	1000	8.9	14	20	27	39	59	70	105	170	240	320	470	670
	750	6.7	10	15	20	29	43	53	83	130	185	235	355	500
125	1500	12	18	26	36	52	81	97	145	230	320	425	610	880
	1000	8	12	17	23	34	53	64	95	155	210	285	420	570
	750	6	9	13	18	26	40	48	71	115	160	210	310	440
140	1500	10.7	16	23	32	46	72	87	130	205	290	380	550	800
	1000	7.15	11	16	21	31	47	58	85	135	190	250	365	520
	750	5.4	8	12	16	23	36	44	65	100	145	190	275	395
160	1500	9.37	14	20	28	41	63	76	115	180	255	340	495	710
	1000	6.25	9.5	14	18	27	42	51	75	120	170	225	330	470
	750	4.68	7.5	10	14	21	32	39	58	91	130	170	250	360
180	1500	8.34	13	19	25	37	57	69	100	160	225	295	435	630
	1000	5.56	8.5	12	17	25	38	46	68	105	150	200	290	420
	750	4.17	6.5	9.5	13	18	29	35	51	81	115	155	220	320
200	1500	7.5	12	15	22	33	51	62	92	145	205	270	395	560
	1000	5	8	10	14	22	34	41	61	96	135	180	260	375
	750	3.75	6	8	11	17	26	30	44	72	100	135	200	280
224	1500	6.7	10	14	19	29	45	55	82	130	185	240	355	500
	1000	4.47	7	9	13	20	30	37	54	86	120	160	235	340
	750	3.35	5	7	10	15	23	28	41	65	92	120	175	255
250	1500	6	9.5	12	17	26	40	48	71	115	165	215	315	450
	1000	4	6	8.5	12	17	27	32	48	77	110	145	210	300
	750	3	4.5	6.5	9	13	20	24	36	58	82	110	155	225
280	1500	5.35	8	11	15	23	36	44	65	100	145	190	275	395
	1000	3.57	5.5	7.5	10	15	24	29	43	67	95	125	185	265
	750	2.67	4	5.5	8	12	18	22	32	50	71	95	140	195
315	1500	4.76	7.5	9.5	13	21	32	39	58	91	130	170	250	355
	1000	3.17	5	6.5	9	14	21	25	37	60	86	115	165	235
	750	2.38	3.5	5	7	10	16	20	29	46	65	86	125	180
355	1500	4.23	6.5	8.5	12	18	29	35	51	82	115	155	225	320
	1000	2.82	4.5	6	8.5	12	19	23	34	53	75	99	145	205
	750	2.12	3	4.5	6.5	9.5	14	17	25	41	58	77	110	160
400	1500	3.75	6	8	11	16	26	31	45	71	100	135	195	280
	1000	2.5	4	5	7.5	11	17	20	30	48	68	90	130	190
	750	1.88	3	4	5.5	8	13	15	23	35	52	66	98	135
450	1500	3.33	5	7.5	10	13	21	29	39	65	92	120	175	255
	1000	2.22	3.5	5	6.5	9	14	19	26	43	60	81	115	170
	750	1.66	2.5	3.5	5	6.5	11	14	19	32	46	60	88	125
500	1500	3	6.5	9	12	19	26	35	58	82	110	155	225	320
	1000	2	4.5	6	8	13	17	23	38	54	72	105	150	215
	750	1.6	3	4.5	6	9.5	13	17	29	41	54	79	115	165
560	1500	2.68	8	11	17	23	30	50	71	95	140	195	280	400
	1000	1.78	5.5	7	11	16	21	35	49	65	94	135	195	280
	750	1.34	4	5.5	8.5	12	16	26	37	49	71	100	140	200
630	1500	2.38	9.5	15	21	28	46	65	86	125	180	255	360	510
	1000	1.59	6.5	10	14	18	30	43	57	83	115	160	230	330
	750	1.19	5	7.5	10	14	23	33	43	63	86	125	180	260
Nominal transmission ratio $i_N$	input speeds [rpm]; $n_1$		Size of gear unit											
			225	250	280	315	355	400	450	500	560	630	710	80
			Thermal capacity, $P_{G1}$ (kW), for gear boxes without cooling											
112 to 630	1500	38	50	66	90	105	135	170	210	275	360	430	550	
	1000	35	45	55	80	95	120	150	200	255	340	410	530	
	750	30	40	53	74	90	110	140	180	225	290	385	490	

For power ratings indicated in **heavy type** a check of the thermal capacity is always necessary (see the example of a calculation). At normal type print this is necessary only at an ambient temperature deviating from 20°C. Thermal capacity,  $P_{G1}$  [kW] and dimensions for gears with fan cooling on request. The nominal transmission ratio is maintained with a tolerance of about ± 3% Intermediate transmission ratios are possible.

**ELECON-ET Series modular gear units**  
 Bevel Helical gear, double reduction

**KBN**

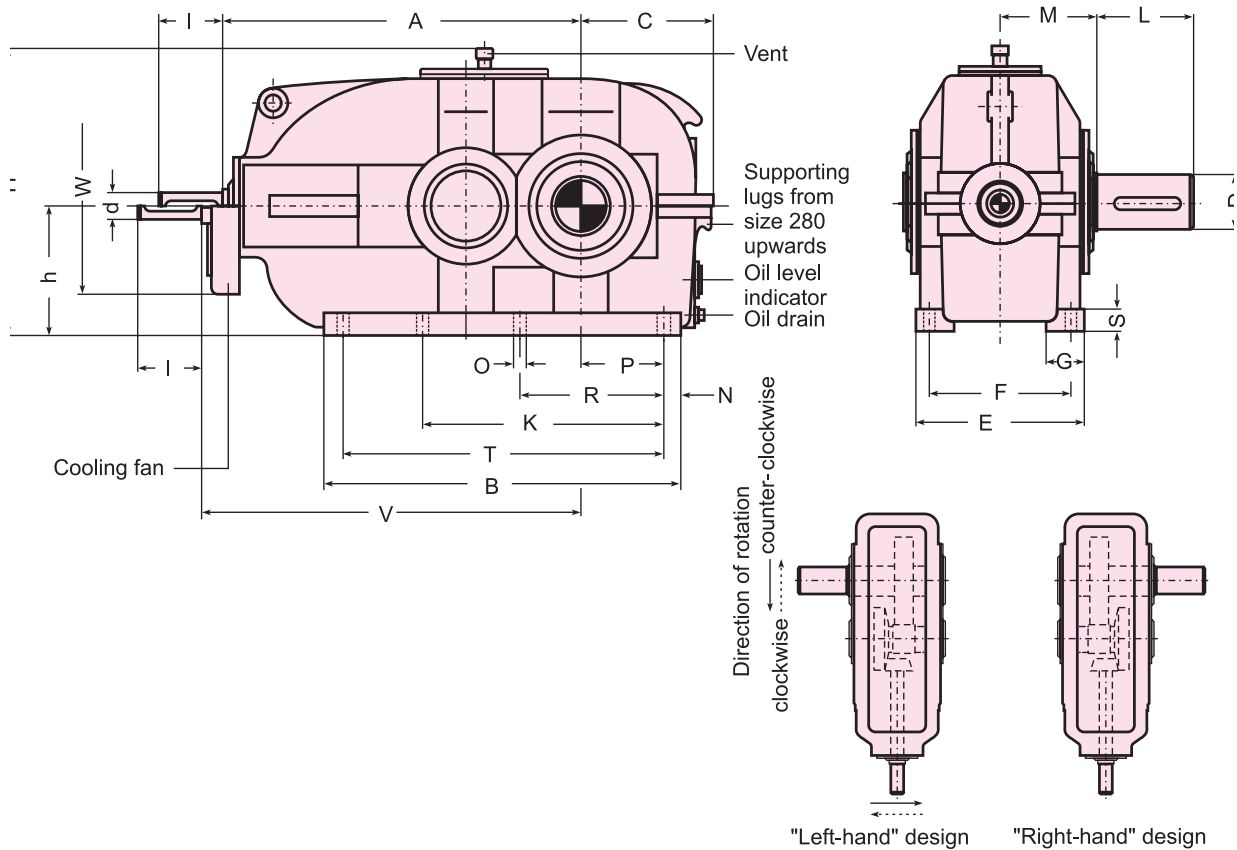

**Example of a gear unit designation :**  
 Gear unit KBN 200 R  
 $P_N = 130$  [kW];  $n_1 = 1500$  rpm ;  
 $n_2 = 150$  [rpm];  $i_N = 10 : 1$

Normal design, size 200  
 R: 'right - hand' design for transmission of 130 [kW]  
 at an input speed of  $n_1 = 1500$  [rpm] and a transmission ratio of  $i_N = 10 : 1$

Size of gear unit	Input Shaft				Output shaft		Dimensions [mm]																Fan cooling		Average weight [kg]	Oil quantity [litres]
	$i_N \leq 10$		$i_N > 10$																				Average	Oil quantity		
	d	l	d	l	D	L	A	B	C	E	F	G	h	H	K	M	N	O	P	R	S	T	V	W		
80	16	40	16	40	32	80	250	245	100	130	105	35	90	230		80	15	11.5	50	95	15	215	350	180	28	1.5
90	20	50	20	50	38	80	280	275	115	140	116	40	100	250		90	15	11.5	60	110	20	245	380	180	37	2
100	20	50	20	50	45	110	315	310	125	160	130	45	110	270		100	20	14	65	120	20	270	415	180	50	2.5
110	25	60	20	50	48	110	350	350	140	180	150	50	125	310		110	20	14	80	140	25	310	450	230	65	3
125	30	80	25	60	55	110	395	395	155	200	170	55	140	340		120	20	14	95	170	25	355	500	230	90	4
140	35	80	30	80	60	140	440	440	175	220	190	60	160	380		135	20	14	110	195	30	400	545	300	120	5
160	40	110	35	80	70	140	500	500	190	250	210	65	180	430		145	30	18	115	210	35	440	605	300	165	7
180	42	110	40	110	80	170	565	565	215	270	230	70	200	475		160	30	18	135	240	35	505	685	380	220	9
200	50	110	45	110	90	170	625	625	240	300	250	75	225	520		175	35	23	145	255	40	555	745	380	290	13
225	55	110	50	110	100	210	705	705	260	320	270	80	250	570		190	35	23	165	290	45	635	835	380	395	18
250	60	140	55	110	110	210	785	785	290	370	310	90	280	625		210	40	27	180	315	50	705	910	530	530	25
280	65	140	60	140	120	210	875	875	325	400	340	100	315	690		230	45	27	200	355	55	785	1015	530	720	36
315	75	140	70	140	140	250	975	975	355	450	380	110	355	785		260	50	33	220	405	60	875	1115	650	970	51
355	90	170	80	170	160	300	1085	1085	390	480	410	120	400	865		285	55	33	245	450	65	975	1220	650	1305	69
400	100	210	90	170	170	300	1215	1215	440	530	460	130	450	960		305	55	33	280	510	70	1105	1350	650	1765	95
450	110	210	95	170	190	350	1365	1365	490	600	510	140	500	1065	940	345	60	39	315	575	80	1245	1500	650	2380	130
500	120	210	110	210	220	350	1525	1525	550	650	560	150	560	1185	1050	475	70	39	350	645	90	1385	1655	650	3950	185
560	130	250	120	210	250	410	1705	1705	610	750	640	160	630	1325	1165	510	80	45	390	715	100	1545	1835	650	5520	260

Larger gear box sizes of this design on enquiry.

Modification of dimensions reserved.

Shaft ends with keys according to DIN 6885, part 1, Shape A.

Shaft centering according to DIN 332, shape DS (with thread)

Tolerance field for shaft ends ISO fit, up to 50 mm  $\pm k 6$ ; over 50 mm  $\pm m 6$ .

**ELECON-ET Series modular gear units, hollow shaft**  
 footmounted - Helical gear, double reduction

**KBH**

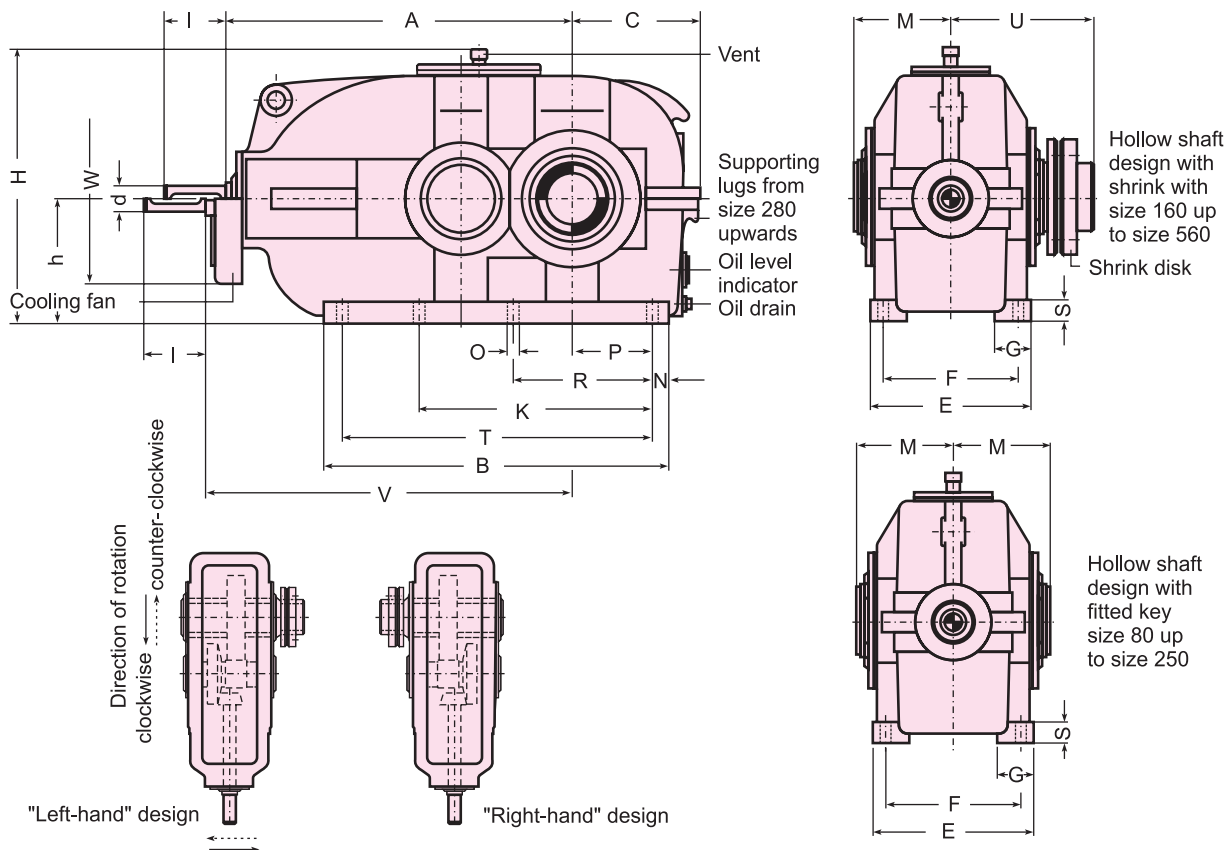

**Example of a gear unit designation :**

Gear unit KBH 200 R  
 $P_N = 130$  [kW];  $n_1 = 1500$  rpm ;  
 $n_2 = 150$  [rpm];  $i_N = 10 : 1$

Normal design, size 200  
 R: 'right - hand' design for transmission of 130 [kW]  
 at an input speed of  $n_1 = 1500$  [rpm] and a transmission ratio of  $i_N = 10 : 1$

Size of gear unit	Input Shaft				Dimensions [mm]																	Fan cooling		Average weight [kg]	Oil quantity [litres]
	$i_N \leq 10$		$i_N > 10$		A	B	C	E	F	G	h	H	K	M	N	O	P	R	S	T	U	V	W		
	d	l	d	l																					
80	16	40	16	40	250	245	100	120	95	35	90	230		80	15	11.5	50	95	15	215		350	180	28	1.5
90	20	50	20	50	280	275	115	140	116	40	100	250		90	15	11.5	60	110	20	245		380	180	37	2
100	20	50	20	50	315	310	125	160	130	45	110	270		100	20	14	65	120	20	270		415	180	50	2.5
110	25	60	20	50	350	350	140	180	150	50	125	310		110	20	14	80	140	25	310		450	230	65	3
125	30	80	25	60	395	395	155	200	170	55	140	340		120	20	14	95	170	25	355		500	230	90	4
140	35	80	30	80	440	440	175	220	190	60	160	380		135	20	14	110	195	30	400		545	300	120	5
160	40	110	35	80	500	500	190	250	210	65	180	430		145	30	18	115	210	35	440	225	605	300	155	7
180	42	110	40	110	565	565	215	270	230	70	200	475		160	30	18	135	240	35	505	250	685	380	220	9
200	50	110	45	110	625	625	240	300	250	75	225	520		175	35	23	145	255	40	555	275	745	380	290	13
225	55	110	50	110	705	705	260	320	270	80	250	570		190	35	23	165	290	45	635	295	835	380	395	18
250	60	140	55	110	785	785	290	370	310	90	280	625		210	40	27	180	315	50	705	325	910	530	530	25
280	65	140	60	140	875	875	325	400	340	100	315	690		230	45	27	200	355	55	785	360	1015	530	720	36
315	75	140	70	140	975	975	355	450	380	110	355	785		260	50	33	220	405	60	875	420	1115	650	970	51
355	90	170	80	170	1085	1085	390	480	410	120	400	865		285	55	33	245	450	65	975	450	1220	650	1305	69
400	100	210	90	170	1215	1215	440	530	460	130	450	960		305	55	33	280	510	70	1105	490	1350	650	1765	95
450	110	210	95	170	1365	1365	490	600	510	140	500	1065	940	345	60	39	315	575	80	1245	550	1500	650	2380	130
500	120	210	110	210	1525	1525	550	650	560	150	560	1185	1050	475	70	39	350	645	90	1385	715	1655	650	3950	185
560	130	250	120	210	1705	1705	610	750	640	160	630	1325	1165	510	80	45	390	715	100	1545	760	1835	650	5520	260

Larger gear box sizes of this design on enquiry.

Modification of dimensions reserved.

Shaft ends with keys according to DIN 6885, part 1, Shape A.

Shaft centering according to DIN 332, shape DS (with thread)

Tolerance field for shaft ends ISO fit, up to 50 mm  $\pm$  k 6; over 50 mm  $\pm$  m 6.

**ELECON-ET Series** modular gear units, shaftmounted  
Bevel Helical gear, double reduction

**KBA**

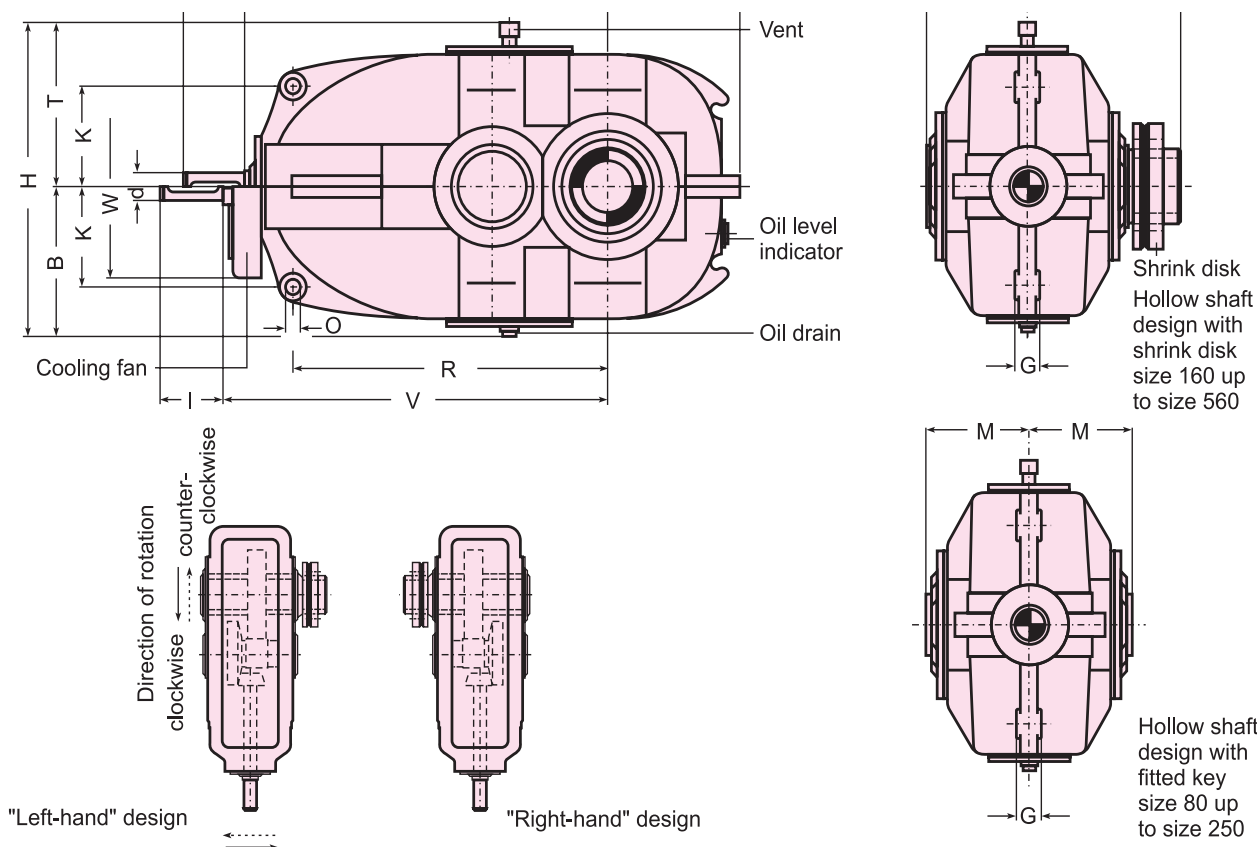

**Example of a gear unit designation :**

Gear unit KBA 200 R

$P_N = 130$  [kW];  $n_1 = 1500$  rpm ;  
 $n_2 = 150$  [rpm];  $i_N = 10 : 1$

Normal design, size 200

R: 'right - hand' design for transmission of 130 [kW]  
at an input speed of  $n_1 = 1500$  [rpm] and a transmission ratio of  $i_N = 10 : 1$

Size of gear unit	Input Shaft				Dimensions [mm]													Fan cooling	Average weight [kg]	Oil quantity [litres]
	$i_N \leq 10$		$i_N > 10$		A	B	C	G	H	K	M	O <sup>H11</sup>	R	T	U	V	W			
	d	l	d	l																
80	16	40	16	40	250	115	100	20	255	75	80	10	215	140		350	180	24	0.5	
90	20	50	20	50	280	130	115	22	280	80	90	12	240	150		380	180	30	0.7	
100	20	50	20	50	315	145	125	25	305	85	100	15	270	160		415	180	42	1	
110	25	60	20	50	350	160	140	25	345	95	110	18	305	185		450	230	55	1.5	
125	30	80	25	60	395	175	155	28	375	105	120	18	340	200		500	230	80	2.5	
140	35	80	30	80	440	195	175	30	415	120	135	20	370	220		545	300	105	3	
160	40	110	35	80	500	215	190	32	465	135	145	20	435	250	225	605	300	145	4	
180	42	110	40	110	565	240	215	35	515	155	160	25	495	275	250	685	380	190	5	
200	50	110	45	110	625	260	240	45	555	170	175	30	560	295	275	745	380	250	8	
225	55	110	50	110	705	290	260	50	610	185	190	35	625	320	295	835	380	330	12	
250	60	140	55	110	785	315	290	55	660	205	210	40	690	345	325	910	530	460	15	
280	65	140	60	140	875	345	325	60	720	225	230	45	770	375	360	1015	530	620	21	
315	75	140	70	140	975	380	355	70	810	260	260	50	875	430	420	1115	650	840	30	
355	90	170	80	170	1085	415	390	80	880	285	285	55	965	465	450	1220	650	1130	40	
400	100	210	90	170	1215	460	440	90	970	310	305	60	1090	510	490	1350	650	1500	55	
450	110	210	95	170	1365	515	490	105	1080	360	345	65	1215	565	550	1500	650	2000	75	
500	120	210	110	210	1525	575	550	105	1200	410	475	70	1360	625	715	1655	650	3265	105	
560	130	250	120	210	1705	645	610	110	1340	450	510	75	1530	695	760	1835	650	4505	150	

Larger gear box sizes of this design on enquiry.

Modification of dimensions reserved.

Shaft ends with keys according to DIN 6885, part 1, Shape A.

Shaft centering according to DIN 332, shape DS (with thread)

Tolerance field for shaft ends ISO fit, up to 50 mm  $\pm k 6$ ; over 50 mm  $\pm m 6$ .

Power ratings

KBN/KBH/KBA

Nominal transmission ratio $i_N$	Nominal speeds [rpm]: $n_1$ $n_2$		Size of gear unit																	
			80	90	100	110	125	140	160	180	200	225	250	280	315	355	400	450	500	560
			Nominal gear box rating $P_N$ (kW)																	
6.3	1500	240	12	18	24	28	45	65	94	115	165	240	360	460	610	790	1290*	1850*	2100*	2400*
	1000	160	8	12	16	21	34	49	70	86	125	180	270	345	465	590	970	1380	1800	2200*
	750	120	6	9	12	17	24	40	56	71	100	145	210	275	380	490	790	1030	1450	1850
7.1	1500	210	12	16	24	28	45	65	94	115	155	225	345	460	610	790	1180*	1740*	2100*	2400*
	1000	140	8	11	16	21	32	49	70	86	115	170	265	345	465	590	890	1310	1800	2200*
	750	105	6	8	12	17	24	34	56	68	94	135	200	275	380	490	720	1030	1450	1850
8	1500	188	9	13	19	28	40	56	81	115	145	205	320	435	610	750	1080*	1680*	2100*	2400*
	1000	125	6	9	13	18	27	38	56	86	110	155	245	325	465	560	810	1260	1700	2200
	750	94	4.5	6.5	10	14	20	29	42	55	88	125	185	250	340	465	660	950	1400	1800
9	1500	167	8	12	18	25	36	51	74	100	135	190	290	395	540	680	980	1540*	2050*	2200*
	1000	111	5.5	8	12	16	24	34	49	76	100	145	220	295	415	510	740	1110	1560	1950
	750	83	4	6	9.5	13	19	26	38	51	79	120	175	230	315	420	600	830	1190	1500
10	1500	150	7.5	10	16	22	32	46	67	92	130	165	255	345	480	610	910	1370	1900*	2200*
	1000	100	5	7	11	15	22	30	44	69	94	125	195	260	360	465	620	950	1270	1700
	750	75	4	5.5	8.5	11	17	23	34	46	73	105	155	210	295	380	510	710	950	1300
11.2	1500	134	6.5	9.5	14	20	29	41	59	81	115	150	235	325	450	560	840	1200	1550	2000*
	1000	89	4.5	6.5	9.5	13	20	27	40	61	84	130	175	245	340	430	630	810	1030	1380
	750	67	3.5	4.8	7.5	10	15	21	31	41	65	98	140	185	240	350	470	610	780	1040
12.5	1500	120	5.5	8.5	13	18	26	36	53	75	105	140	210	285	390	500	760	980	1260	1550*
	1000	80	3.9	5.5	8.5	12	18	25	36	56	74	105	145	215	265	380	480	660	850	1110
	750	60	3	4.2	6.5	9	13	19	27	36	56	76	110	150	190	270	365	500	640	840
14	1500	107	5	7.5	10	14	23	32	48	66	81	125	190	260	345	465	580	780	1000	1150
	1000	71	3.5	5	6.5	9	15	21	31	42	54	84	110	165	205	310	415	520	680	900
	750	53	2.6	3.7	4.9	7	11	15	23	31	38	60	80	115	145	235	310	400	510	690
16	1500	94	4.3	6	7.5	11	18	24	37	51	60	105	135	205	260	410	480	600	840	1000
	1000	62	2.8	3.7	5	7.5	11	15	24	32	37	63	81	125	150	250	350	410	560	720
	750	47	2.1	2.8	3.7	5.5	8.5	11	17	23	27	46	59	88	110	180	260	305	425	600
18	1500	83	3.3	4.5	6	8.5	13													
	1000	56	2.2	2.9	3.9	5.5	8.5													
	750	41	1.6	2.2	2.9	4.2	6.5													
Nominal transmission ratio $i_N$	input speeds [rpm]: $n_1$		Size of gear unit																	
			80	90	100	110	125	140	160	180	200	225	250	280	315	355	400	450	500	560
			Thermal capacity, $P_{G1}$ (kW), for gear boxes without cooling																	
6.3 to 11.2	1500	11	16	21	26	31	38	50	65	90	125	140	170	220	275	355	430	550	675	
	1000	10	15	20	24	29	36	48	62	86	110	135	165	210	270	340	420	545	665	
	750	9	13	18	21	26	35	46	58	80	105	130	155	205	260	330	415	535	660	
12.5 to 18	1500	10	15	18	24	28	36	48	62	86	110	135	165	215	265	340	420	545	665	
	1000	9	13	16	22	25	34	45	54	78	105	125	160	205	260	335	415	535	655	
	750	8	12	15	19	23	32	41	50	73	100	120	150	200	255	330	410	530	650	
			Thermal capacity, $P_{G2}$ (kW), for gear boxes with fan cooling																	
6.3 to 11.2	1500	28	35	45	56	70	90	110	150	195	250	330	380	510	620	800	990	1200	1500	
	1000	26	33	42	52	63	82	100	140	175	230	305	350	450	550	700	830	1100	1400	
	750	22	30	37	48	55	75	95	125	150	205	260	300	400	500	620	780	950	1300	
12.5 to 18	1500	25	33	42	54	68	86	105	140	180	230	310	370	480	600	750	950	1150	1450	
	1000	21	29	36	46	58	72	92	120	150	200	260	320	430	520	660	810	1000	1300	
	750	16	24	30	40	50	64	82	105	135	180	230	280	380	480	600	740	930	1200	
			Thermal capacity, $P_{G3}$ (kW), for gear boxes with cooling coil																	
6.3 to 18	1500	20	26	32	42	56	70	90	110	135	170	210	260	330	425	575	760	975	1175	
	1000	18	24	30	40	54	65	83	106	131	160	200	255	310	420	570	740	965	1165	
	750	15	22	29	37	51	61	81	104	130	155	194	250	300	410	565	715	935	1110	
			Thermal capacity, $P_{G4}$ (kW), for gear boxes with fan and cooling coil																	
6.3 to 18	1500	37	45	56	72	95	122	150	195	240	305	400	470	620	770	1020	1200	1500	2000	
	1000	34	42	52	68	88	111	135	188	220	280	370	440	550	700	930	1150	1400	1900	
	750	28	39	48	64	80	101	130	171	200	255	324	395	495	650	855	1080	1350	1750	

For power ratings indicated in **heavy type** a check of the thermal capacity is always necessary (see the example of a calculation).  
 At normal type print this is necessary only at an ambient temperature deviating from 20°C. The nominal gear powers,  $P_N$ [kW] marked with \* require forced feed lubrication by a pump. The nominal transmission ratio is maintained with a tolerance of about ± 3% Intermediate transmission ratios are possible.

**ELECON-ET Series** modular gear units  
Bevel Helical gear, triple reduction

**KCN**

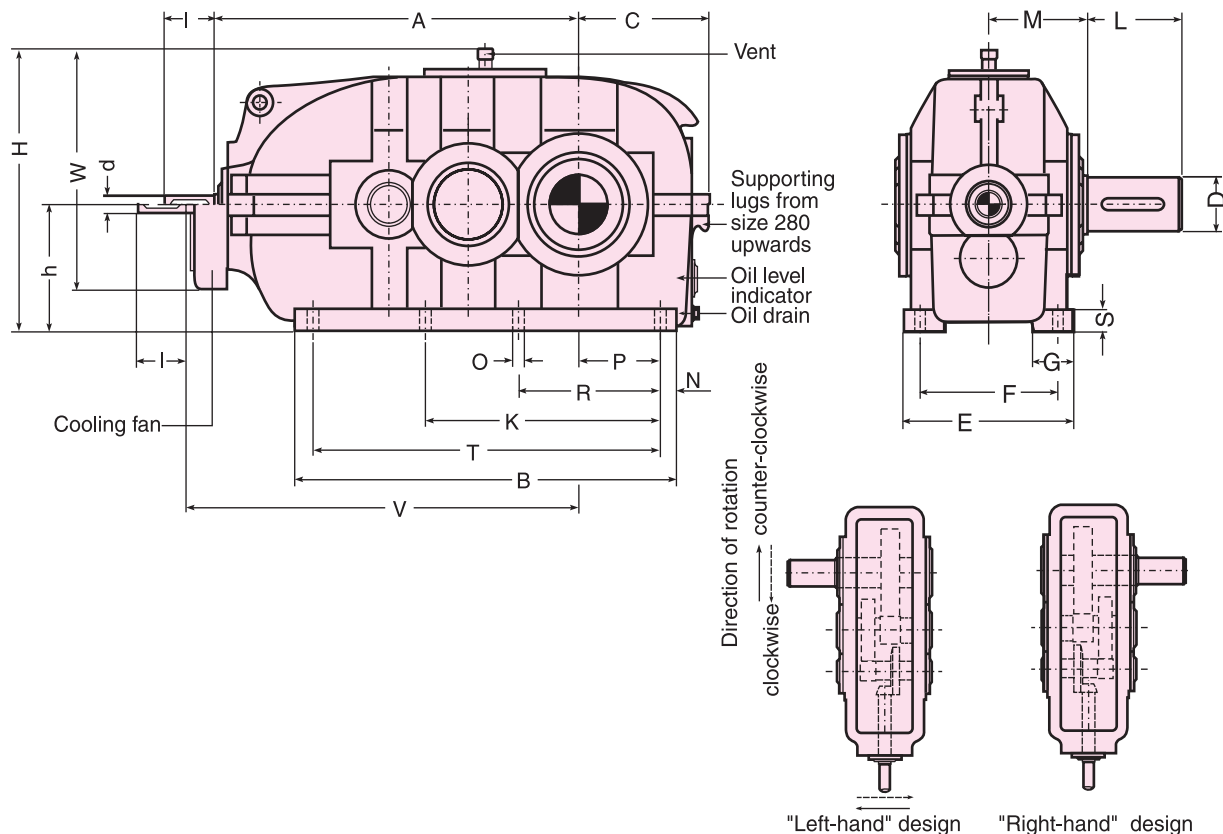

**Example of a gear unit designation :**

Gear unit KCN 200 R  
 $P_N = 36$  [kW];  $n_1 = 1500$  rpm ;  
 $n_2 = 38$  [rpm];  $i_N = 40 : 1$

Normal design, size 200

R: 'right - hand' design for transmission of 36 [kW]  
 at an input speed of  $n_1 = 1500$  [rpm] and a transmission ratio of  $i_N = 40 : 1$

Size of gear unit	Input Shaft upto size = 450				Output shaft		Dimensions [mm]																Fan cooling		Average weight [kg]	Oil quantity [litres]
	$i_N \leq 45$		$i_N > 45$				D	L	A	B	C	E	F	G	h	H	K	M	N	O	P	R	S	T		
	d	l	d	l																						
110	16	40	16	40	48	110	360	385	140	180	150	50	125	310		110	20	14	80	140	25	345	460	230	70	3.5
125	20	50	20	50	55	110	405	435	155	200	170	55	140	340		120	20	14	95	170	25	395	505	230	95	4.5
140	20	50	20	50	60	140	455	490	175	220	190	60	160	380		135	20	14	110	195	30	450	555	300	130	6.5
160	25	60	20	50	70	140	510	555	190	250	210	65	180	430		145	30	18	115	210	35	495	610	300	175	9
180	30	80	25	60	80	170	575	625	215	270	230	70	200	475		160	30	18	135	240	35	565	680	380	235	13
200	35	80	30	80	90	170	640	685	240	300	250	75	225	520		175	35	23	145	255	40	615	745	380	320	18
225	40	110	35	80	100	210	725	775	260	320	270	80	250	570		190	35	23	165	290	45	705	830	380	430	26
250	42	110	40	110	110	210	815	860	285	370	310	90	280	625		210	40	27	180	315	50	780	935	530	580	33
280	50	110	45	110	120	210	905	970	325	400	340	100	315	690		230	45	27	200	355	55	880	1025	530	780	46
315	55	110	50	110	140	250	1020	1085	355	450	380	110	355	785	655	260	50	33	220	405	60	985	1150	650	1060	65
355	60	140	55	110	160	300	1140	1220	390	480	410	120	400	865	740	285	55	33	245	450	65	1110	1265	650	1430	90
400	65	140	60	140	170	300	1275	1355	440	530	460	130	450	960	840	305	55	33	280	510	70	1245	1415	650	1930	125
450	75	140	70	140	190	350	1425	1520	490	600	510	140	500	1065	940	345	60	39	315	575	80	1400	1565	650	2590	180
500	90	170	80	170	220	350	1585	1690	550	650	560	150	560	1185	1050	475	70	39	350	645	90	1550	1720	650	4280	240
560	100	210	90	170	250	410	1775	1895	610	750	640	160	630	1325	1165	510	80	45	390	715	100	1735	1910	650	5580	335
630	110	210	95	170	300	470	1995	2145	675	800	690	170	710	1460	1305	560	80	45	445	800	110	1985	2130	650	7950	480
710	120	210	110	210	340	550	2235	2400	760	900	770	190	800	1665	1490	600	90	45	500	900	125	2220	2365	650	10650	690
800	130	250	120	210	400	650	2505	2700	840	1000	870	200	900	1870	1680	645	90	45	560	1100	140	2520	2635	650	14700	940

**Larger gear box sizes of this design on enquiry.**

Dimensions not binding. Get certified drawings for installation purpose.

Modification of dimensions reserved.

Shaft ends with keys according to DIN 6885, part 1, Shape A.

Shaft centering according to DIN 332, shape DS (with thread)

Tolerance field for shaft ends ISO fit, up to 50 mm  $\pm k 6$ ; over 50 mm  $\pm m 6$ .

**ELECON-ET Series** modular gear units, hollow shaft, footmounted - Bevel Helical gear, triple reduction

**KCH**

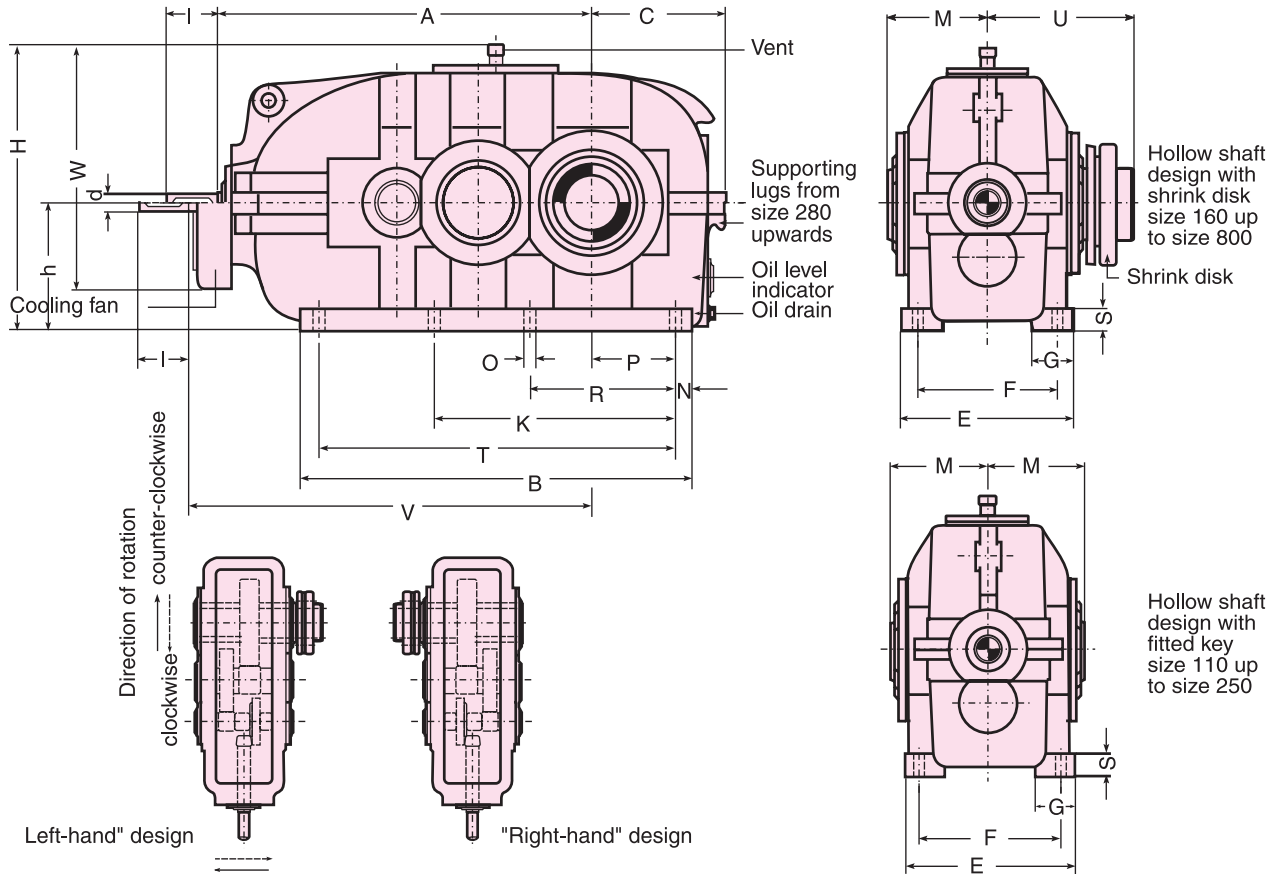

**Example of a gear unit designation :**

Gear unit KCH 200 R  
 $P_N = 36$  [kW];  $n_1 = 1500$  rpm ;  
 $n_2 = 38$  [rpm];  $i_N = 40 : 1$

Normal design, size 200

R: 'right - hand' design for transmission of 36 [kW] at an input speed of  $n_1 = 1500$  [rpm] and a transmission ratio of  $i_N = 40 : 1$

Size of gear unit	Input Shaft upto size = 450		Input Shaft upto size = 450		Dimensions [mm]																	Fan cooling		Average weight [kg]	Oil quantity [litres]				
	$i_N \leq 45$		$i_N > 45$		d	l	d	l	A	B	C	E	F	G	h	H	K	M	N	O	P	R	S			T	U	V	W
	size 500 and above		size 500 and above																										
110	16	40	16	40	360	385	140	180	150	50	125	310		110	20	14	80	140	25	345		460	230	<b>70</b>	3.5				
125	20	50	20	50	405	435	155	200	170	55	140	340		120	20	14	95	170	25	395		505	230	<b>95</b>	4.5				
140	20	50	20	50	455	490	175	220	190	60	160	380		135	20	14	110	195	30	450		555	300	<b>130</b>	6.5				
160	25	60	20	50	510	555	190	250	210	65	180	430		145	30	18	115	210	35	495	225	610	300	<b>175</b>	9				
180	30	80	25	60	575	625	215	270	230	70	200	475		160	30	18	135	240	35	565	250	680	380	<b>235</b>	13				
200	35	80	30	80	640	685	240	300	250	75	225	520		175	35	23	145	255	40	615	275	745	380	<b>320</b>	18				
225	40	110	35	80	725	775	260	320	270	80	250	570		190	35	23	165	290	45	705	295	830	380	<b>430</b>	26				
250	42	110	40	110	815	860	285	370	310	90	280	625		210	40	27	180	315	50	780	325	935	530	<b>580</b>	33				
280	50	110	45	110	905	970	325	400	340	100	315	690		230	45	27	200	355	55	880	360	1025	530	<b>780</b>	46				
315	55	110	50	110	1020	1085	355	450	380	110	355	785	655	260	50	33	220	405	60	985	420	1150	650	<b>1060</b>	65				
355	60	140	55	110	1140	1220	390	480	410	120	400	865	740	285	55	33	245	450	65	1110	450	1265	650	<b>1430</b>	90				
400	65	140	60	140	1275	1355	440	530	460	130	450	960	840	305	55	33	280	510	70	1245	490	1415	650	<b>1930</b>	125				
450	75	140	70	140	1425	1520	490	600	510	140	500	1065	940	345	60	39	315	575	80	1400	550	1565	650	<b>2590</b>	180				
500	90	170	80	170	1585	1690	550	650	560	150	560	1185	1050	475	70	39	350	654	90	1550	715	1720	650	<b>4280</b>	240				
560	100	210	90	170	1775	1895	610	750	640	160	630	1325	1165	510	80	45	390	715	100	1735	760	1910	650	<b>5580</b>	335				
630	110	210	95	170	1995	2145	675	800	690	170	710	1460	1305	560	80	45	445	800	110	1985	840	2130	650	<b>7950</b>	480				
710	120	210	110	210	2235	2400	760	900	770	190	800	1665	1490	600	90	45	500	900	125	2220	890	2365	650	<b>10650</b>	690				
800	130	250	120	210	2505	2700	840	1000	870	200	900	1870	1680	645	90	45	560	1100	140	2520	955	2635	650	<b>14700</b>	940				

Larger gear box sizes of this design on enquiry.

Modification of dimensions reserved.

Shaft ends with keys according to DIN 6885, part 1, Shape A.

Shaft centering according to DIN 332, shape DS (with thread)

Tolerance field for shaft ends ISO fit, up to 50 mm  $\pm k 6$ ; over 50 mm  $\pm m 6$ .

**ELECON-ET Series modular gear units,**  
shaftmounted Bevel Helical gear, double reduction

**KCA**

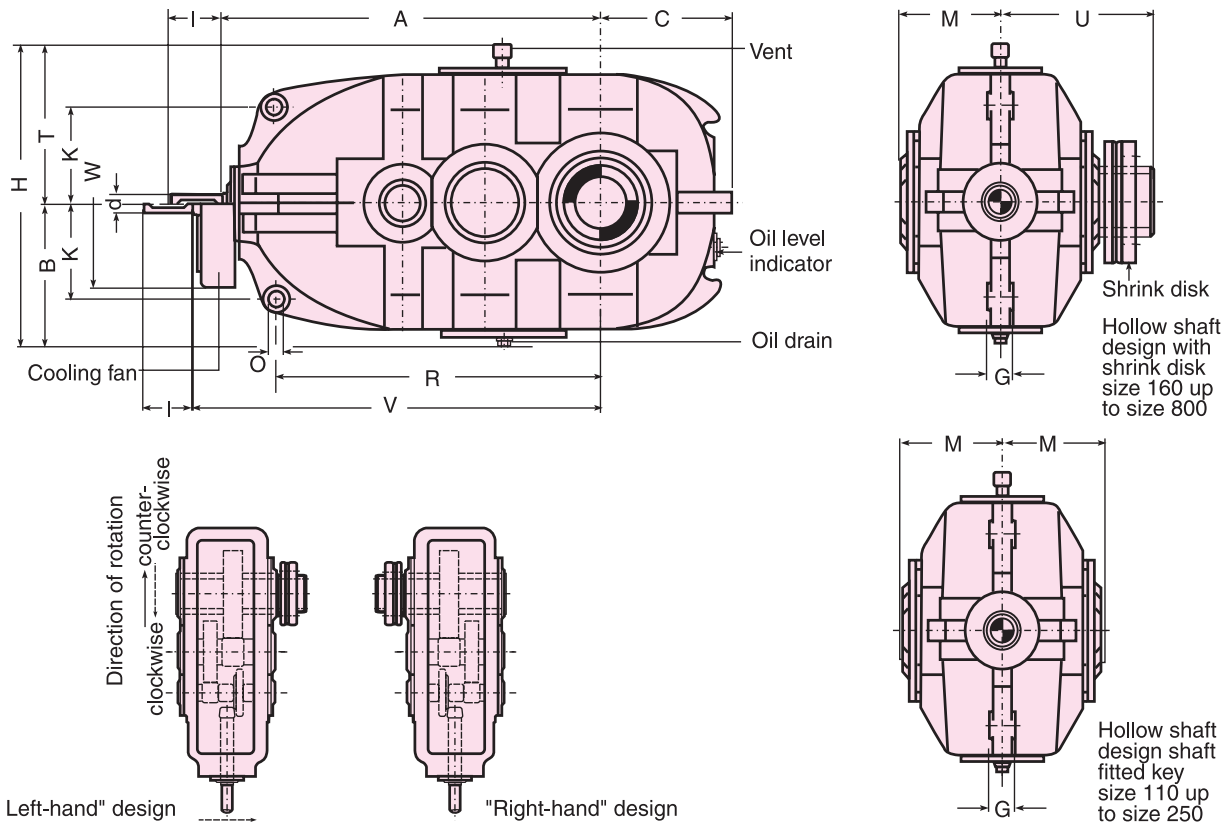

**Example of a gear unit designation :**

Gear unit KCA 200 R  
 $P_N = 36$  [kW];  $n_1 = 1500$  rpm ;  
 $n_2 = 38$  [rpm];  $i_N = 40 : 1$

Normal design, size 200

R: 'right - hand' design for transmission of 36 [kW]  
 at an input speed of  $n_1 = 1500$  [rpm] and a trans-  
 mission ratio of  $i_N = 40 : 1$

Size of gear unit	Input Shaft up to size = 450 $i_N \leq 45$ size 500 and above $i_N \leq 50$				Dimensions [mm]												Fan cooling		Average weight [kg]	Oil quantity [litres]
	d	l	d	l	A	B	C	G	H	K	M	O <sup>H11</sup>	R	T	U	V	W			
110	16	40	16	40	360	160	140	25	345	95	110	18	315	185		460	230	65	2	
125	20	50	20	50	405	175	155	28	375	105	120	18	355	200		505	230	85	3	
140	20	50	20	50	455	195	175	30	415	120	135	20	395	220		555	300	115	4	
160	25	60	20	50	510	215	190	32	465	135	145	20	435	250	225	610	300	150	6	
180	30	80	25	60	575	240	215	35	515	155	160	25	495	275	250	680	380	205	8	
200	35	80	30	80	640	260	240	45	555	170	175	30	555	295	275	745	380	280	12	
225	40	110	35	80	725	290	260	50	610	185	190	35	635	320	295	830	380	370	17	
250	42	110	40	110	815	315	285	55	660	205	210	40	710	345	325	935	530	500	21	
280	50	110	45	110	905	345	325	60	720	225	230	45	800	375	360	1025	530	670	28	
315	55	110	50	110	1020	380	355	70	810	260	260	50	895	430	420	1150	650	910	40	
355	60	140	55	110	1140	415	390	80	880	285	285	55	995	465	450	1265	650	1170	55	
400	65	140	60	140	1275	460	440	90	970	310	305	60	1110	510	490	1415	650	1580	80	
450	75	140	70	140	1425	515	490	105	1080	360	345	65	1245	565	550	1565	650	2070	115	
500	90	170	80	170	1585	575	550	105	1200	410	475	70	1400	625	715	1720	650	3420	150	
560	100	210	90	170	1775	645	610	110	1340	450	510	75	1580	695	760	1910	650	4500	215	
630	110	210	95	170	1995	725	675	115	1500	465	560	80	1795	775	840	2130	650	6400	300	
710	120	210	110	210	2235	830	760	120	1695	535	600	85	2020	865	890	2365	650	8585	420	
800	130	250	120	210	2505	940	840	125	1910	605	645	90	2280	975	955	2635	650	11550	580	

Larger gear box sizes of this design on enquiry.

Modification of dimensions reserved.

Shaft ends with keys according to DIN 6885, part 1, Shape A.

Shaft centering according to DIN 332, shape DS (with thread)

Tolerance field for shaft ends ISO fit, up to 50 mm  $\pm k 6$ ; over 50 mm  $\pm m 6$ .

Power ratings

KCN/KCH/KCA

Nominal transmission ratio $i_N$	Nominal speeds [rpm]; $n_1$ $n_2$		Size of gear unit																	
			110	125	140	160	180	200	225	250	280	315	355	400	450	500	560	630	710	800
			Nominal gear box rating $P_N$ (kW)																	
14	1500	107	16	22	32	45	63	85	120	170	240	320	440	620*	830*	1350*	1850*	2500*		
	1000	71	11	15	23	30	46	60	85	120	175	235	330	450	630	1010	1420*	2200*	2500*	2850*
	750	54	8.5	12	17	24	35	45	70	90	145	190	270	360	510	830	1180	1750	2300*	2600*
16	1500	94	15	22	30	45	61	80	120	160	230	305	440	600*	830*	1350*	1850*	2500*		
	1000	63	10	14	21	30	43	60	85	115	170	230	330	440	630	1010	1420*	2200*	2500*	2850*
	750	47	8	12	17	24	35	45	70	85	140	185	270	360	510	830	1180	1600	2300*	2600*
18	1500	83	13	20	28	42	58	75	110	150	210	290	440	560	780*	1350*	1850*	2500*	2700*	
	1000	56	9	13	19	30	40	53	75	105	155	215	330	420	590	1000	1400*	1860*	2500*	2850*
	750	42	7	10	15	23	32	42	65	80	120	175	260	345	480	790	1120	1460	2180	2500
20	1500	75	12	17	25	39	53	68	100	135	195	270	430	550	780*	1320*	1800*	2460*	2650*	
	1000	50	8	12	17	27	36	48	70	95	140	200	315	380	550	880	1240*	1640*	2400*	2850*
	750	38	6	9	13	20	28	38	55	75	110	160	245	310	445	700	1000	1290	1920*	2500*
22.4	1500	67	10	15	22	34	50	65	94	130	175	250	400	510	730*	1170*	1540*	2170*	2500*	2850*
	1000	45	7	11	15	23	34	48	65	90	130	185	290	360	520	780	1100	1450*	2120*	2600*
	750	33	5.5	8	11	17	25	36	49	70	95	140	220	275	400	620	880	1140	1710	2460*
25	1500	60	9	14	20	30	44	62	83	115	160	225	350	450	650	1030*	1460*	1930*	2500*	2850*
	1000	40	6.5	9.5	14	20	30	42	57	80	110	165	255	315	460	730	1040	1350*	2010*	2600*
	750	30	4.7	7	10	15	23	32	43	60	85	125	195	240	350	550	780	1010	1510	2180*
28	1500	54	8	11	18	22	37	48	75	92	140	215	320	405	590	910*	1290*	1710*	2400*	2700*
	1000	36	5.5	8	12	15	25	34	52	66	94	150	225	285	420	640	910	1190	1770*	2500*
	750	27	4.1	6	9	12	19	26	39	50	71	115	170	215	315	490	690	890	1330	1920*
31.5	1500	48	7	10	16	20	33	44	69	85	120	195	290	385	550	820*	1170*	1540*	2260*	2500*
	1000	32	4.8	7	11	14	22	31	46	59	83	130	200	255	370	580	820	1070*	1600*	2310*
	750	24	3.6	5.5	8	10	17	23	34	44	62	100	150	190	280	440	620	800	1200	1740*
35.5	1500	42	6.5	9.5	15	18	30	40	62	77	110	180	260	345	500	770*	1100*	1430*	2120*	2400*
	1000	28	4.3	6.5	10	12	20	28	42	53	75	120	180	230	340	510	720	950	1410*	2030*
	750	21	3.2	4.8	7.5	9	15	21	31	40	56	90	135	175	250	385	540	710	1060	1540
40	1500	38	6	8.5	13	17	27	36	56	69	98	160	235	310	450	690	990*	1290*	1920*	2200*
	1000	25	3.9	5.5	9.5	11	18	25	41	47	67	120	160	225	330	465	660	860	1280	1850*
	750	19	2.9	4.4	6.5	8.5	14	19	29	36	52	82	125	155	230	350	495	640	960	1390
45	1500	33.5	5	7.5	12	15	24	33	50	64	90	145	215	275	400	620	880	1150*	1720*	2100*
	1000	22	3.5	5	8	10	16	22	33	42	60	95	145	180	265	455	640	840	1250	1810
	750	16.6	2.7	4	6	7.5	12	17	26	32	46	74	110	140	205	320	455	600	870	1260
50	1500	30	4.6	7	11	13	21	30	44	57	80	130	195	245	360	550	780	1030	1540*	2050*
	1000	20	3.1	4.6	7	9	14	20	31	38	54	87	130	165	240	365	520	680	1020	1480
	750	15	2.4	3.5	5.5	7	11	15	23	29	41	65	99	120	180	290	410	540	780	1130
56	1500	27	4.1	6	9.5	12	19	26	39	50	71	115	170	220	320	500	700	920	1370*	1980*
	1000	18	2.8	4.2	6.5	8	13	18	27	34	49	78	115	145	215	340	485	640	930	1340
	750	13.4	2.1	3.1	4.6	6	10	14	21	26	37	59	88	110	165	255	360	475	690	990
63	1500	24	3.7	5.5	8.5	10	17	23	35	44	63	100	150	195	285	440	620	810	1220	1550*
	1000	16	2.5	3.7	5.5	7	12	16	24	30	43	69	105	130	190	300	430	560	820	1110
	750	12	1.9	2.8	4.2	5.5	8.5	12	18	23	32	52	78	98	145	230	325	430	620	840
71	1500	21	3.2	4.8	7.5	9	15	21	31	40	56	90	135	175	250	395	560	730	1000	1150
	1000	14	2.2	3.3	5	6.5	10	14	22	27	37	62	81	115	160	265	380	500	680	900
	750	10.5	1.7	2.5	3.7	4.8	7.5	11	16	20	27	46	59	86	110	200	285	380	510	690
80	1500	18.8	2.9	4.4	6	9	12	19	29	40	55	74	115	160	210	350	480	600	850	1050
	1000	12.5	2	3	4.2	6	8	14	20	27	37	50	79	110	145	240	340	410	560	720
	750	9.4	1.5	2.2	3.1	4.5	8	10	15	20	27	38	59	81	110	180	255	305	425	600
90	1500	16.7	2.3	3.9	5.5	8	10	18	26	36	46	67	110	145	190	310	385	520	800	920
	1000	11.1	1.5	2.5	3.7	5.5	7	12	17	24	29	41	67	95	115	180	260	355	540	650
	750	8.3	1.1	1.9	2.8	4	5.5	9	13	18	21	30	48	68	85	130	195	270	410	510
100	1500	15		2.8	5	7	9.5	16	21	30	34	50	82	120	140	230	320	430	650	850
	1000	10		1.8	3.3	4.6	6.5	10	13	19	22	31	50	64	85	135	205	295	435	550
	750	7.5		1.3	2.4	3.4	4.9	7.5	9.5	14	16	23	37	46	62	97	145	225	330	440
Nominal transmission ratio $i_N$	input speeds [rpm]; $n_1$		Size of gear unit																	
			110	125	140	160	180	200	225	250	280	315	355	400	450	500	560	630	710	800
			Thermal capacity, $P_{G1}$ (kW), for gear boxes without cooling																	
14 to 35.5	1500		21	26	32	42	51	65	85	102	133	168	202	250	305	386	485	605	760	960
	1000		19	23	29	38	49	60	78	100	120	158	192	240	292	375	480	595	740	940
	750		17	20	26	34	45	55	72	95	118	152	183	232	282	370	465	585	720	920
40 to 100	1500		18	24	30	38	48	60	75	96	123	157	191	242	300	380	475	595	750	950
	1000		17	21	27	36	46	57	74	94	115	150	181	228	277	365	460	580	730	930
	750		15	19	24	32	42	54	70	92	110	140	170	215	265	350	445	560	705	900
			Thermal capacity, $P_{G2}$ (kW), for gear boxes with fan cooling																	
			110	125	140	160	180	200	225	250	280	315	355	400	450	500	560	630	710	800
			Thermal capacity, $P_{G3}$ (kW), for gear boxes with cooling coil																	
14 to 100	1500		50	62	80	100	120	150	195	225	290	380	465	550	715	900	1160	1450	1)	1)
	1000		48	60	76	95	115	135	175	210	260	345	410	470	595	770	1000	1300	1)	1)
	750		46	58	72	90	110	125	160	190	230	300	360	420	530	695	920	1190	1)	1)
40 to 100	1500		47	60	76	96	115	140	180	212	255	320	390	480	620	760	950	1290	1)	1)
	1000		45	56	72	86	108	130	165	195	240	290	350	450	580	700	890	1180	1)	1)
	750		43	52	66	80	100	120	156	180	220	270	310	410	520	655	860	1100	1)	1)
			Thermal capacity, $P_{G4}$ (kW), for gear boxes with fan and cooling coil																	
			110	125	140	160	180	200	225	250	280	315	355	400	450	500	560	630	710	800
			Thermal capacity, $P_{G4}$ (kW), for gear boxes with fan and cooling coil																	
14 to 100	1500		100	120	145	180	210	250	320	370	470	530	630	785	950	1160	1360	1700	1)	1)
	1000		98	118	140	170	200	235	290	350	440	495	575	695	820	990	1180	1540	1)	1)
	750		96	115	135	160	185	220	270	325	408	448	525	650	760	910	1080	1400	1)	1)

For power ratings indicated in **heavy type** a check of the thermal capacity is always necessary (see the example of a calculation). At normal type print this is necessary only at an ambient temperature deviating from

**ELECON-ET Series modular gear units,**  
Bevel Helical gear, quadruple reduction

**KDN**

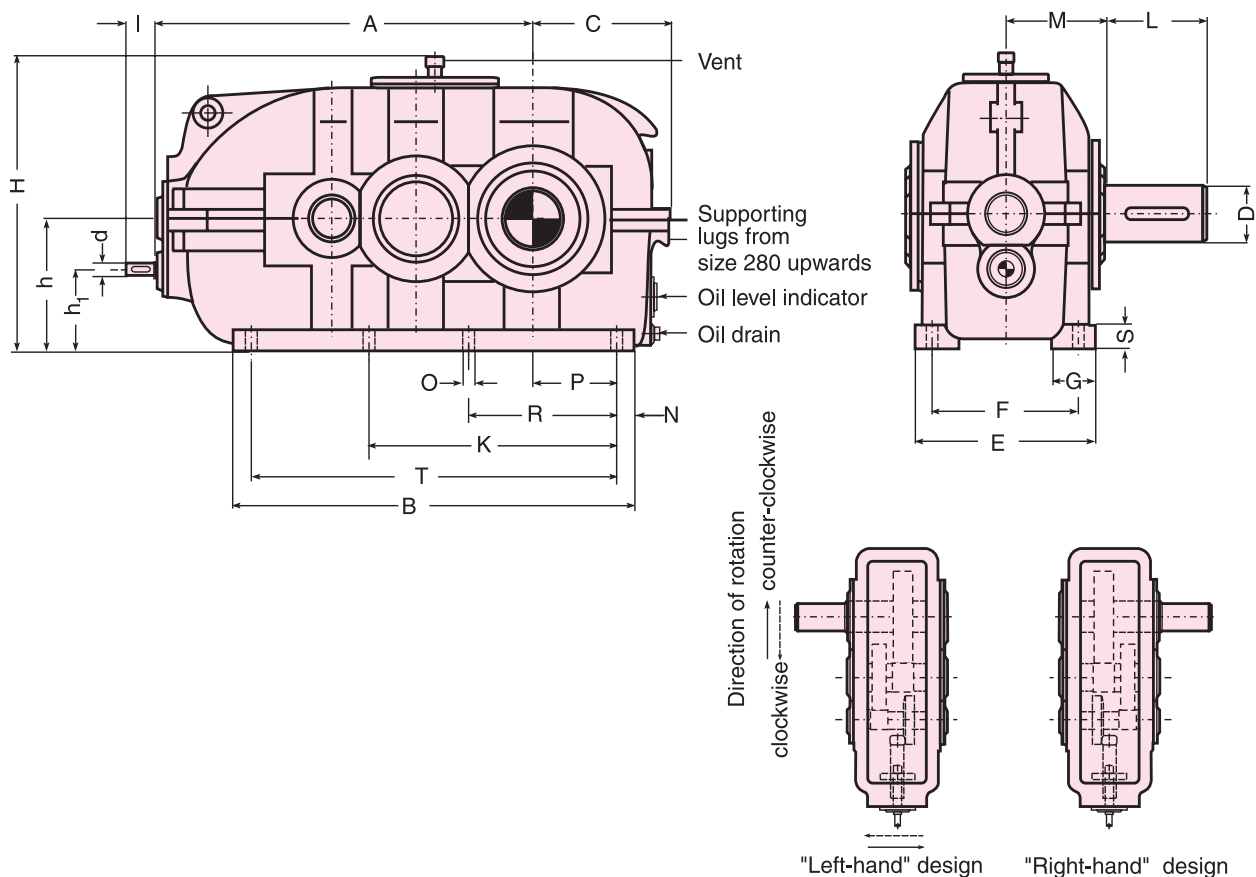

**Example of a gear unit designation :**

Gear unit KDN 280 R  
 $P_N = 22$  [kW];  $n_1 = 1500$  rpm ;  
 $n_2 = 7.5$  [rpm];  $i_N = 200 : 1$

Normal design, size 280  
 R: 'right - hand' design for transmission of 22 [kW]  
 at an input speed of  $n_1 = 1500$  [rpm] and a transmission ratio of  $i_N = 200 : 1$

Size of gear unit	Input Shaft				Output shaft	Dimensions [mm]																Average weight [kg]	Oil quantity [litres]			
	$i_N \leq 355$		$i_N > 355$			d	l	d	l	D	L	A	B	C	E	F	G	h	h <sub>1</sub>	H	K			M	N	O
160	19	40	19	40	70	140	510	555	190	250	210	65	180	100	430		145	30	18	115	210	35	495	175	9	
180	19	40	19	40	80	170	575	625	215	270	230	70	200	120	475		160	30	18	135	240	35	565	235	13	
200	19	40	19	40	90	170	640	685	240	300	250	75	225	145	520		175	35	23	145	255	40	615	320	18	
225	22	50	22	50	100	210	725	775	260	320	270	80	250	160	570		190	35	23	165	290	45	705	430	26	
250	25	60	22	50	110	210	815	860	285	370	310	90	280	180	625		210	40	27	180	315	50	780	580	33	
280	30	80	25	60	120	210	905	970	325	400	340	100	315	205	690		230	45	27	200	355	55	880	780	46	
315	35	80	30	80	140	250	1020	1085	355	450	380	110	355	230	785	655	260	50	33	220	405	60	985	1060	65	
355	45	110	35	80	160	300	1140	1220	390	480	410	120	400	260	865	740	285	55	33	245	450	65	1110	1430	90	
400	50	110	40	110	170	300	1275	1355	440	530	460	130	450	290	960	840	305	55	33	280	510	70	1245	1930	125	
450	55	110	45	110	190	350	1425	1520	490	600	510	140	500	320	1065	940	345	60	39	315	575	80	1400	2590	180	
500	60	140	50	110	220	350	1585	1690	550	650	560	150	560	360	1185	1050	475	70	39	350	645	90	1550	4280	240	
560	70	140	55	110	250	410	1775	1895	610	750	640	160	630	405	1325	1165	510	80	45	390	715	100	1735	5850	335	
630	75	140	60	140	300	470	1995	2145	675	800	690	170	710	460	1460	1305	560	80	45	445	800	110	1985	7950	480	
710	85	170	70	140	340	550	2235	2400	760	900	770	190	800	520	1665	1490	600	90	45	500	900	125	2220	10650	690	
800	100	210	90	170	400	650	2505	2700	840	1000	870	200	900	585	1870	1680	645	90	45	560	1100	140	2520	14700	940	

Larger gear box sizes of this design on enquiry.

Modification of dimensions reserved.  
 Shaft ends with keys according to DIN 6885, part 1, Shape A.  
 Shaft centering according to DIN 332, shape DS (with thread)  
 Tolerance field for shaft ends ISO fit, up to 50 mm  $\epsilon$  k 6; over 50 mm  $\epsilon$  m 6.

**ELECON-ET Series** modular gear units, hollow shaft, footmounted - Bevel Helical gear, quadruple reduction

**KDH**

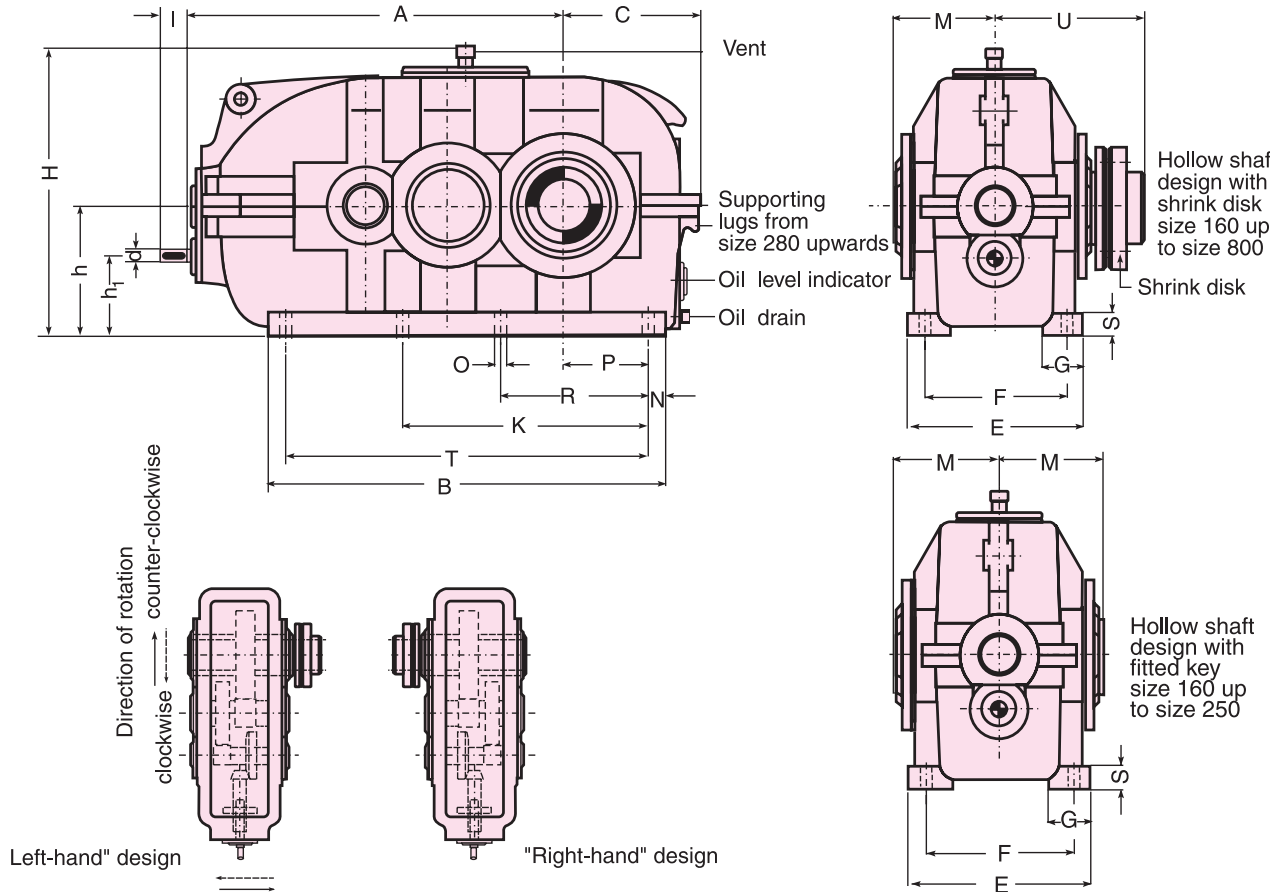

**Example of a gear unit designation :**

Gear unit KDH 280 R  
 $P_N = 22$  [kW];  $n_1 = 1500$  [rpm];  
 $n_2 = 7.5$  [rpm];  $i_N = 200 : 1$

Normal design, size 280

R: 'right - hand' design for transmission of 22 [kW] at an input speed of  $n_1 = 1500$  [rpm] and a transmission ratio of  $i_N = 200 : 1$

Size of gear unit	Input Shaft				Dimensions [mm]																	Average weight [kg]	Oil quantity [litres]	
	$i_N \leq 500$		$i_N > 500$		A	B	C	E	F	G	h	h <sub>1</sub>	H	K	M	N	O	P	R	S	T			U
	d	l	d	l																				
160	19	40			510	555	190	250	210	65	180	100	430		145	30	18	115	210	35	495	225	175	9
180	19	40			575	625	215	270	230	70	200	120	475		160	30	18	135	240	35	565	250	235	13
200	19	40			640	685	240	300	250	75	225	145	520		175	35	23	145	255	40	615	275	320	18
225	22	50			725	775	260	320	270	80	250	160	570		190	35	23	165	290	45	705	295	430	26
250	25	60	22	50	815	860	285	370	310	90	280	180	625		210	40	27	180	315	50	780	325	580	33
280	30	80	25	60	905	970	325	400	340	100	315	205	690		230	45	27	200	355	55	880	360	780	46
315	35	80	30	80	1020	1085	355	450	380	110	355	230	785	655	260	50	33	220	405	60	985	420	1060	65
355	45	110	35	80	1140	1220	390	480	410	120	400	260	865	740	285	55	33	245	450	65	1110	450	1430	90
400	50	110	40	110	1275	1355	440	530	460	130	450	290	960	840	305	55	33	280	510	70	1245	490	1930	125
450	55	110	45	110	1425	1520	490	600	510	140	500	320	1065	940	345	60	39	315	575	80	1400	550	2590	180
500	60	140	50	110	1585	1690	550	650	560	150	560	360	1185	1050	475	70	39	350	645	90	1550	715	4280	240
560	70	140	55	110	1775	1895	610	750	640	160	630	405	1325	1165	510	80	45	390	715	100	1735	760	5850	335
630	75	140	60	140	1995	2145	675	800	690	170	710	460	1460	1305	560	80	45	445	800	110	1985	840	7950	480
710	85	170	70	140	2235	2400	760	900	770	190	800	520	1665	1490	600	90	45	500	900	125	2220	890	10650	690
800	100	210	90	170	2505	2700	840	1000	870	200	900	585	1870	1680	645	90	45	560	1100	140	2520	955	14700	940

Larger gear box sizes of this design on enquiry.

Modification of dimensions reserved.

Shaft ends with keys according to DIN 6885, part 1, Shape A.  
 Shaft centering according to DIN 332, shape DS (with thread)  
 Tolerance field for shaft ends ISO fit, up to 50 mm  $\pm k 6$ ; over 50 mm  $\pm m 6$ .

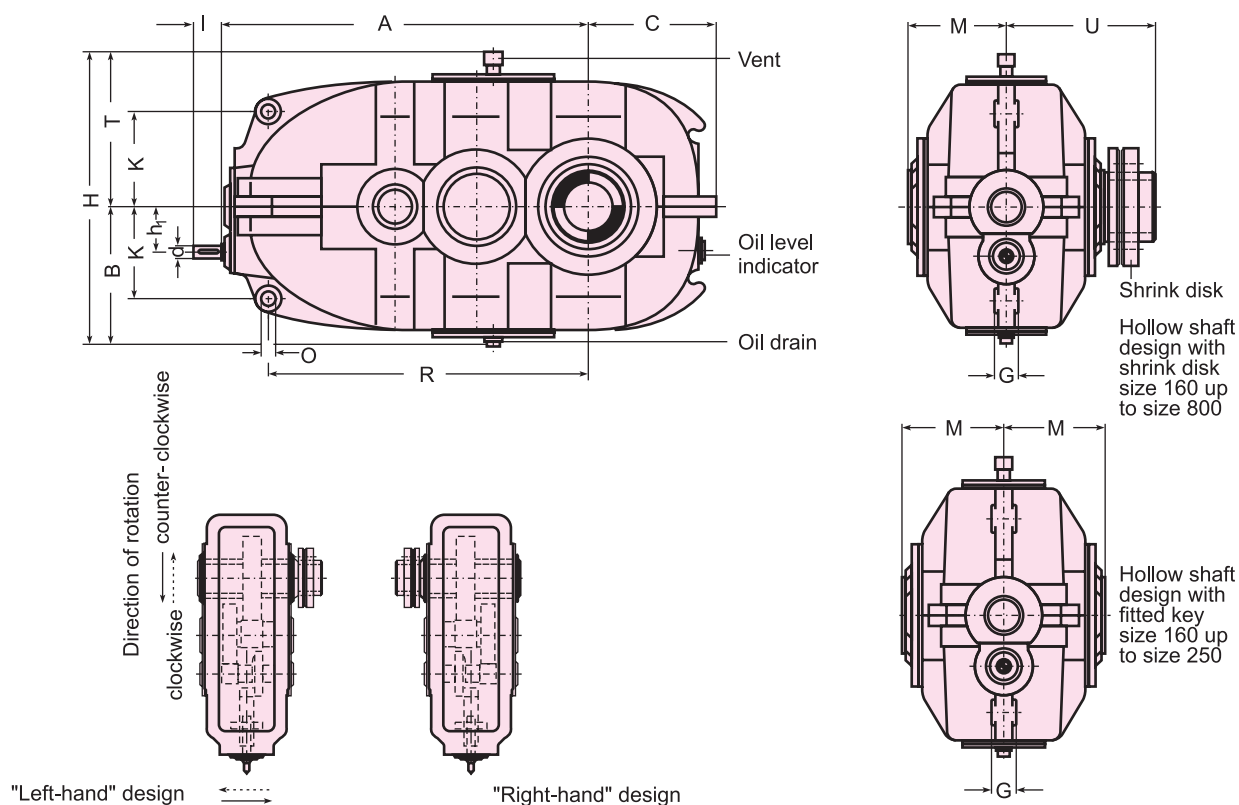

**Example of a gear unit designation :**

Gear unit KDA 280 R  
 $P_N = 22$  [kW];  $n_1 = 1500$  [rpm];  
 $n_2 = 7.5$  [rpm];  $i_N = 200 : 1$

Normal design, size 280

R: 'right - hand' design for transmission of 22 [kW]  
 at an input speed of  $n_1 = 1500$  [rpm] and a transmission ratio of  $i_N = 200 : 1$

Size of gear unit	Input Shaft				Dimensions [mm]												Average weight [kg]	Oil quantity [litres]
	$i_N \leq 500$		$i_N > 500$		A	B	C	G	$h_1$	H	K	M	$O^{H11}$	R	T	U		
	d	l	d	l														
160	19	40			510	215	190	32	80	465	135	145	20	435	250	225	150	6
180	19	40			575	240	215	35	80	515	155	160	25	495	275	250	205	8
200	19	40			640	260	240	45	80	555	170	175	30	555	295	275	280	12
225	22	50			725	290	260	50	90	610	185	190	35	635	320	295	370	17
250	25	60	22	50	815	315	285	55	100	660	205	210	40	710	345	325	500	21
280	30	80	25	60	905	345	325	60	110	720	225	230	45	800	375	360	670	28
315	35	80	30	80	1020	380	355	70	125	810	260	260	50	895	430	420	910	40
355	45	110	35	80	1140	415	390	80	140	880	285	285	55	995	465	450	1170	55
400	50	110	40	110	1275	460	440	90	160	970	310	305	60	1110	510	490	1580	80
450	55	110	45	110	1425	515	490	105	180	1080	360	345	65	1245	565	550	2070	115
500	60	140	50	110	1585	575	550	105	200	1200	410	475	70	1400	625	715	3350	150
560	70	140	55	110	1775	645	610	110	225	1340	450	510	75	1580	695	760	4800	215
630	75	140	60	140	1995	725	675	115	250	1500	465	560	80	1795	775	840	6400	300
710	85	170	70	140	2235	830	760	120	280	1695	535	600	85	2020	865	890	8750	420
800	100	210	90	170	2505	940	840	125	315	1910	605	645	90	2280	970	966	11200	580

Larger gear box sizes of this design on enquiry.

Modification of dimensions reserved.

Shaft ends with keys according to DIN 6885, part 1, Shape A.

Shaft centering according to DIN 332, shape DS (with thread)

Tolerance field for shaft ends ISO fit, up to 50 mm  $\pm k 6$ ; over 50 mm  $\pm m 6$ .

Power ratings

KDN/KDH/KDA

Nominal transmission ratio $i_N$	Nominal speeds rpm $n_1$ $n_2$		Size of gear unit														
			160	180	200	225	250	280	315	355	400	450	500	560	630	710	800
			Nominal gear box rating $P_N$ (kW)														
100	1500	15						41	65	98	135	180	290	400	540	780	1130
	1000	10						27	44	65	84	120	190	270	360	520	750
	750	7.5						21	33	50	64	90	145	205	270	395	560
112	1500	13.4	6	9.5	13	21	27	37	59	86	110	160	255	360	480	690	900
	1000	8.9	4.1	7	9.5	14	18	25	39	60	70	105	170	240	320	470	670
	750	6.7	3	5	7	10	14	19	29	44	53	83	130	185	235	355	500
125	1500	12	5.5	9	12	18	24	33	52	78	97	145	230	320	425	610	880
	1000	8	3.7	6	8.5	12	16	23	34	53	65	95	155	210	285	420	570
	750	6	2.7	4.6	6.5	9	12	17	26	40	48	71	115	160	210	310	440
140	1500	10.7	4.9	8	11	16	22	29	46	70	87	130	205	290	380	550	800
	1000	7.15	3.3	5.5	7.5	11	15	21	31	48	58	85	135	190	250	365	520
	750	5.4	2.5	4.1	5.5	8	11	16	23	36	44	65	100	145	190	275	395
160	1500	9.37	4.4	7.5	10	14	20	27	41	63	76	115	180	255	340	495	710
	1000	6.25	2.9	4.9	7	9.5	13	18	27	42	51	75	120	170	225	330	470
	750	4.68	2.2	3.6	5	7.5	10	14	21	32	39	58	91	130	170	250	360
180	1500	8.34	3.9	6.5	9	13	17	24	37	57	69	100	160	225	295	435	630
	1000	5.56	2.6	4.3	6	8.5	12	16	25	38	46	68	105	150	200	290	420
	750	4.17	2	3.2	4.5	6.5	9	12	19	29	35	51	81	115	155	220	320
200	1500	7.5	3.5	5.8	8	12	15	22	33	51	62	92	145	205	270	395	560
	1000	5	2.3	3.8	5.5	8	10	14	22	34	41	61	96	135	180	260	375
	750	3.75	1.9	2.9	4.3	6	8	11	17	26	30	44	72	100	135	200	280
224	1500	6.7	3.1	5	7	10	14	19	30	45	55	82	130	185	240	355	500
	1000	4.47	2.1	3.4	4.7	7	9	13	20	30	37	54	86	120	160	235	340
	750	3.35	1.7	2.6	3.8	5	7	10	15	23	28	41	65	92	120	175	255
250	1500	6	2.8	4.6	6.5	9.5	12	17	26	40	48	71	115	165	215	315	450
	1000	4	1.9	3.1	4.7	6	8.5	12	17	27	32	48	77	110	145	210	300
	750	3	1.5	2.3	3.4	4.5	6.5	9	13	20	24	36	58	82	110	155	225
280	1500	5.35	2.7	3.4	5.5	8	11	15	23	36	44	65	100	145	190	275	395
	1000	3.57	1.7	2.3	3.8	5.5	7.5	11	16	24	29	43	67	95	125	185	265
	750	2.67	1.2	1.6	2.7	4.1	5.5	8	12	18	22	32	50	71	95	140	195
315	1500	4.76	2.3	3.1	5	7.5	9.5	14	21	32	39	58	91	130	170	250	335
	1000	3.17	1.6	2.1	3.5	4.8	6.5	9	14	21	25	37	60	86	115	165	225
	750	2.38	1.2	1.5	2.6	3.7	5	7	11	16	20	29	46	65	86	125	170
355	1500	4.23	2.1	2.8	4.6	6.5	8.5	11	18	23	35	43	82	115	155	205	275
	1000	2.82	1.3	1.9	3	4.3	6	7.5	12	16	23	29	53	75	99	135	185
	750	2.12	1.0	1.3	2.3	3.2	4.4	5.5	9	12	17	21	41	58	77	105	140
400	1500	3.75	1.7	2.4	3.8	5	7.5	9	15	19	28	35	71	100	120	170	240
	1000	2.5	1.1	1.5	2.5	3.3	5	6	10	13	19	24	47	68	81	115	160
	750	1.88	0.8	1.2	1.9	2.5	3.7	4.5	7.5	9.5	14	17	35	52	61	85	120
450	1500	3.33	1.3	2.1	3	5	7	9	13	19	28	35	57	88	105	150	215
	1000	2.22	0.9	1.4	2	3.3	5	6	9	13	19	24	38	61	73	100	145
	750	1.60	0.7	1.1	1.5	2.5	3.7	4.5	7	9.5	14	17	28	45	54	76	105
500	1500	3				3.8	6	7	9.5	16	22	25	43	70	96	145	185
	1000	2				2.5	4	4.6	6.5	11	15	17	29	47	64	99	125
	750	1.5				1.9	3.1	3.4	4.8	8	11	12	21	35	48	73	92
560	1500	2.68					5.5	6	8.5	14	20	22	38	62	85	130	165
	1000	1.79					3.6	4	5.5	9.5	13	15	26	42	57	87	110
	750	1.34					2.7	3	4.2	7	10	11	19	31	43	64	82
630	1500	2.38						4.8	7	11	14	17	29	43	70	105	140
	1000	1.59						3.2	4.6	7.5	9.5	11	19	29	46	69	93
	750	1.19						2.4	3.4	5.5	7	8.5	14	21	35	52	70
Nominal transmission ratio $i_N$	input speeds rpm $n_1$		Size of gear unit														
			160	180	200	225	250	280	315	355	400	450	500	560	630	710	800
			Thermal capacity, $P_{G1}$ (kW), for gear boxes without cooling														
100 to 630	1500	17	22	28	36	45	60	76	100	122	152	195	240	305	390	510	
	1000	15	18	24	32	40	55	66	85	110	135	175	230	290	365	490	
	750	14	16	23	30	35	45	62	80	102	130	160	205	285	345	470	

For power ratings indicated in **heavy type** a check of the thermal capacity is always necessary (see the example of a calculation). At normal type print this is necessary only at in an ambient temperature deviating from 20°C. Thermal capacity,  $P_{G2}$ [kW] and dimensions for gears with fan cooling on request. The nominal transmission ratio is maintained with a tolerance of about ± 3% Intermediate transmission ratios are possible.

## COOLING TOWER GEAR TYPE : KBV - NL

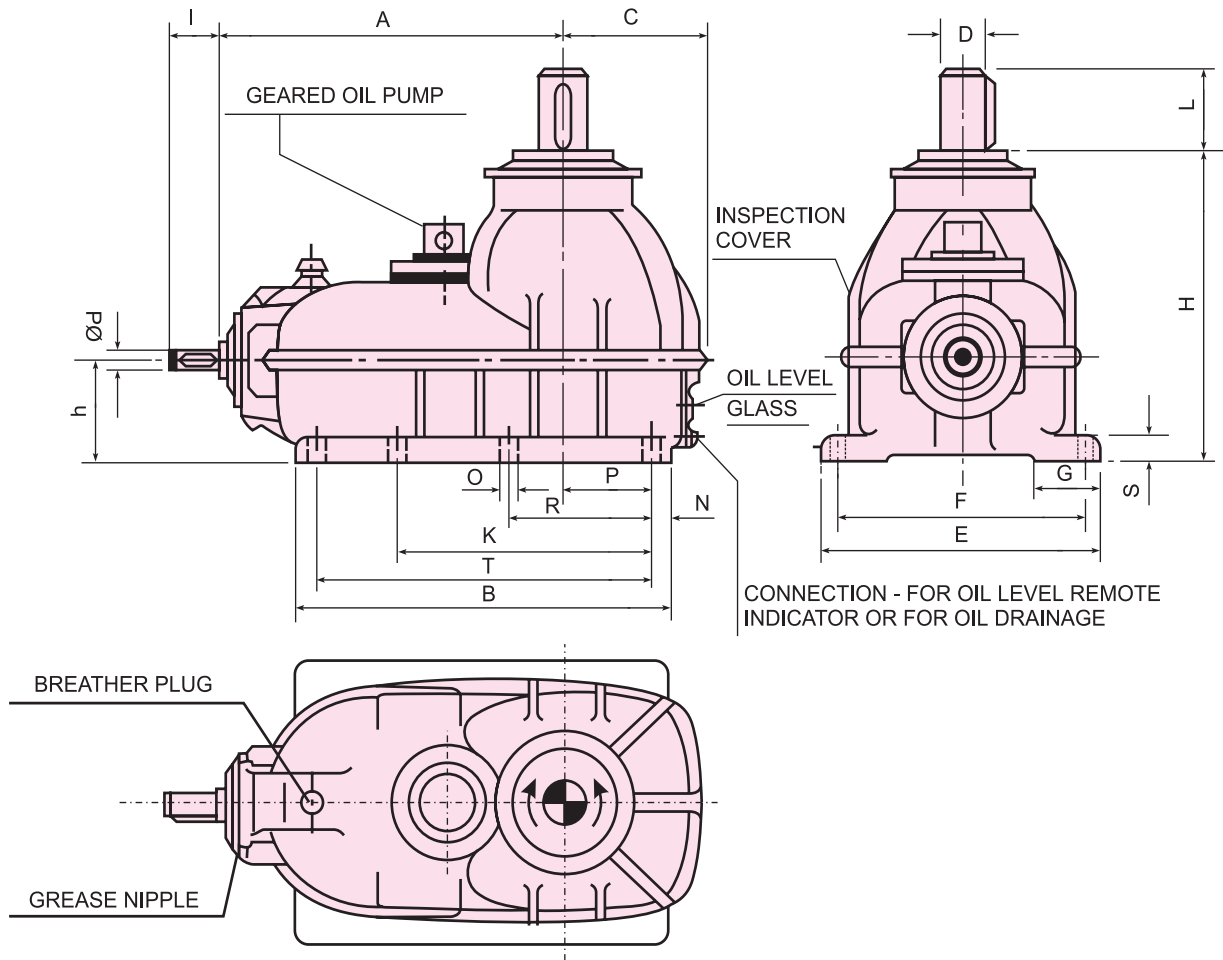

Gear Size	DRIVE SHAFT				OUTPUT SHAFT	DIMENSIONS [mm]															WEIGHT [kg]	OIL QUANTITY [LITRES]		
	$i_N \leq 10$		$i_N > 10$			D	L	A	B	C	E	F	G	H	h	K	N	O	P	R			S	T
	d	l	d	l																				
160	40	110	35	80	70	140	500	500	190	400	360	110	420	140		30	18	115	210	35	440	220	8	
180	42	110	40	110	80	170	565	565	215	450	410	120	480	160		30	18	135	240	35	505	290	11	
200	50	110	45	110	90	170	625	625	240	500	450	130	540	180		35	23	145	255	40	555	375	16	
225	55	110	50	110	100	210	705	705	260	550	500	140	600	200		35	23	165	290	45	635	490	21	
250	60	140	55	110	110	210	785	785	290	620	560	145	680	225		40	27	180	315	50	705	645	29	
280	65	140	60	140	120	210	875	875	325	690	630	160	750	250		45	27	200	355	55	785	845	39	
315	75	140	70	140	140	250	975	975	355	770	700	170	840	280		50	33	220	405	60	875	1170	51	
355	90	170	80	170	160	300	1085	1085	390	840	770	180	950	315		55	33	245	450	75	975	1620	67	
400	100	210	90	170	170	300	1215	1215	440	930	860	190	1070	355		55	33	280	510	90	1105	2230	87	
450	110	210	95	170	190	350	1365	1365	490	1030	940	200	1200	400	940	60	39	315	575	100	1245	3080	115	

Shaft ends with key as per DIN - 6885, Sheet 1, from A  
 Shaft centering as per din-332 form DS (With threads)  
 Tolerance field for shaft ends ISO fit up to  $\pm 50\text{mm k6}$  over  $\pm 50\text{mm m6}$   
 Changes of dimension reserved

NOMINAL GEAR RATIO $i_N$	NOMINAL SPEEDS [RPM]; $n_1$   $n_2$		GEAR SIZE									
			160	180	200	225	250	280	315	355	400	450
			VENTILATOR CAPACITY $P_e$ (kW)									
6.3	1500	240	54	74	102*	141*	194*	267*	370*	510*	708*	972*
	1000	160	36	49	68	94	129	178	247	340	472	648
7.1	1500	210	48	66	91	126*	174*	239*	332*	457*	632*	871*
	1000	140	32	44	61	84	116	159	221	305	421	581
8	1500	188	43	59	82	113	156	213*	296*	408*	565*	778*
	1000	125	29	39	55	75	104	142	197	272	376	519
9	1500	167	38	53	73	101	139	190	264*	364*	504*	694*
	1000	111	25	35	49	67	93	127	176	243	336	463
10	1500	150	34	47	65	90	124	170	236	325*	450*	620*
	1000	100	23	31	43	60	83	113	157	217	300	413
11.2	1500	134	30	42	58	80	111	152	211	290	402*	554*
	1000	89	20	28	39	53	74	101	141	193	268	369
12.5	1500	120	27	37	52	72	99	136	188	259	359	494
	1000	80	18	25	35	48	66	91	125	173	239	329
14	1500	107	24	33	46	64	88	121	168	231	320	441
	1000	71	16	22	31	43	59	81	112	154	213	294
16	1500	94	22	30	41	57	79	108	150	207	286	394
	1000	62	15	20	27	38	53	72	100	138	191	263
18	1500	83	19	27	37	51	70	96	134	184	255	352
	1000	56	13	18	25	34	47	64	89	123	170	235
			LIMITING THERMAL OUT PUT (PG(kW)) FOR GEAR WITHOUT COOLING.									
			65	80	100	125	160	200	250	315	400	500
			PERMISSIBLE AXIAL LOAD OF THE OUTPUT SHAFT.									
			1600	1800	2000	2300	2650	3000	4000	5000	6000	7000

\* THE CAPACITIES MARKED WITH REQUIRED AN ADDITIONAL COOLING  
**ABOVE RATINGS ARE INCLUSIVE OF SF=2.0, HENCE NO SF IS TO BE CONSIDERED ON MOTOR POWER**

## Hollow shaft design with shrink disc

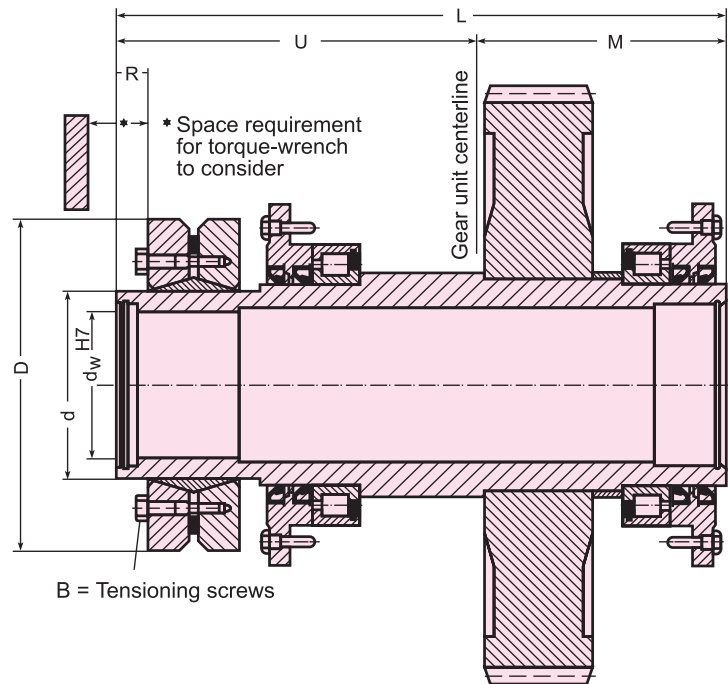

Size of Gear Unit	Hollow shaft					Shrink disc							Weight [kg]
	$d_w$	L	M	R	U	Type	D	d	$M_t$ [da Nm]	B	$M_s$ [da Nm]		
160	80	370	145	26	225	110-72	185	110	900	M 10	5.8	5.9	
180	90	410	160	27	250	125-72	215	125	1300	M 10	5.8	8.3	
200	100	450	175	32	275	140-71	230	140	1760	M 12	10	10	
225	110	485	190	33	295	155-71	263	155	2500	M 12	10	15	
250	120	535	210	37	325	165-71	290	165	3500	M 12	24	22	
280	135	590	230	35	360	175-71	300	175	4800	M 16	24	22	
315	160	680	260	37	420	220-71	370	220	10000	M 16	24	54	
355	180	735	285	38	450	240-71	405	240	13800	M 20	47	67	
400	200	795	305	46	490	260-71	430	260	18400	M 20	47	82	
450	220	895	345	48	550	280-71	460	280	24500	M 20	47	102	
500	280	1190	475	61	715	350-71	570	350	50000	M 20	47	204	
560	310	1270	510	67	760	390-71	660	390	71000	M 20	47	260	
630	340	1400	560	71	840	420-71	690	420	84000	M 20	47	316	
710	380	1490	600	73	890	460-71	770	460	114000	M 20	47	420	
800	420	1600	645	82	955	500-71	850	500	160000	M 20	47	575	

$M_a$  = Required tightening torque.

$M_t$  = Maximum torque transmitted by shrink disc.



# Machine shafts

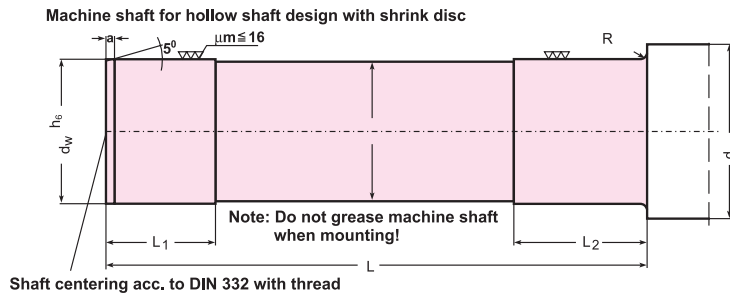

Size of gear unit	a	$d_M$ (min)	$d_w$	$d_i$	L	$L_1$	$L_2$	R
160	5	100	80	78	355	65	90	1.6
180	5	110	90	88	395	70	100	1.6
200	5	125	100	98	430	75	110	1.6
225	5	135	110	108	465	80	120	1.6
250	6	150	120	118	510	90	130	2.5
280	6	165	135	133	565	100	140	2.5
315	6	190	160	158	655	120	160	2.5
355	6	210	180	178	710	125	170	2.5
400	8	240	200	198	765	145	190	4
450	8	260	220	218	860	150	200	4
500	10	320	280	278	1145	240	290	4
560	10	350	310	308	1225	260	310	4
630	12	380	340	338	1355	280	330	6
710	12	430	380	378	1440	300	350	6
800	12	470	420	418	1550	320	380	6

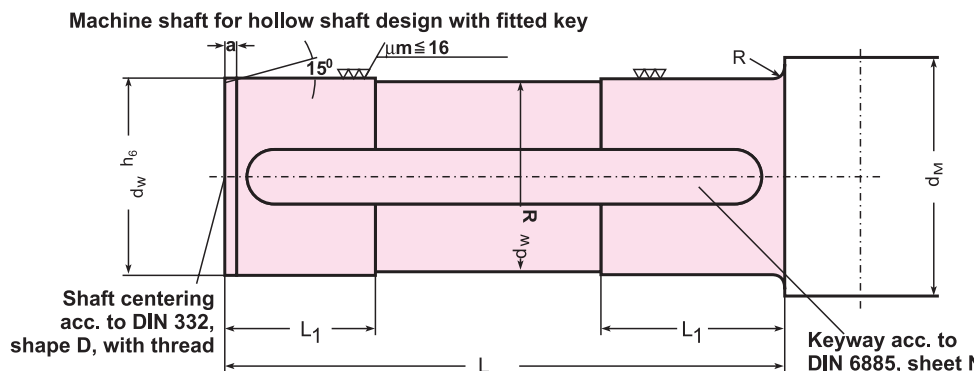

Size of gear unit	a	$d_M$ (min)	$d_w$	L	$L_1$	R
80	3	55	35	157	35	2.5
90	3	60	40	177	40	2.5
100	3	70	50	197	50	2.5
110	4	75	55	217	55	2.5
125	4	80	60	237	60	2.5
140	4	90	70	267	70	2.5
160	5	95	75	287	75	4
180	5	110	90	317	90	4
200	5	125	105	347	105	4
225	5	135	110	377	115	4
250	6	150	120	417	130	6

1) Dim.  $d_w$  with fitting tolerance g6 from diameter 160mm upwards.

**Inertia, GD<sup>2</sup> [kgm<sup>2</sup>]  
relative to the input shaft**

**Type SAN**

Size of gear unit	Transmission ratio												
	1.6	1.8	2	2.24	2.5	2.8	3.15	3.55	4	4.5	5	5.6	6.3
80	0.0056	0.0049	0.0044	0.0038	0.0035	0.0031	0.0028	0.0022	0.0019	0.0017			
90	0.0114	0.0099	0.0087	0.0075	0.0066	0.0057	0.0050	0.0041	0.0035	0.0030	0.0027		
100	0.0192	0.0167	0.0150	0.0134	0.0117	0.0103	0.0092	0.0074	0.0065	0.0056	0.0049	0.0039	
110	0.0329	0.0287	0.0256	0.0229	0.0205	0.0183	0.0164	0.0120	0.0104	0.0090	0.0078	0.0063	0.0057
125	0.0609	0.0538	0.0485	0.0428	0.0385	0.0338	0.0303	0.0229	0.0197	0.0171	0.0149	0.0119	0.0103
140	0.1043	0.0917	0.0813	0.0725	0.0644	0.0564	0.0510	0.0388	0.0343	0.0290	0.0256	0.0208	0.0178
160	0.1892	0.1649	0.1486	0.1316	0.1183	0.1042	0.0926	0.0723	0.0631	0.0538	0.0472	0.0392	0.0333
180	0.3497	0.3074	0.2743	0.2416	0.2157	0.1745	0.1675	0.1291	0.1125	0.0967	0.0846	0.0695	0.0586
200	0.5755	0.5108	0.4507	0.4038	0.3514	0.3106	0.2735	0.2160	0.1898	0.1618	0.1403	0.1139	0.0983
225	1.0014	0.8801	0.7836	0.6958	0.6205	0.5547	0.4881	0.3858	0.3318	0.2896	0.2529	0.2074	0.1741
250	1.6644	1.4768	1.3113	1.1620	1.0322	0.9146	0.8067	0.6536	0.5627	0.4931	0.4262	0.3441	0.2923
280	2.8507	2.5158	2.2396	1.9785	1.7872	1.5897	1.3822	1.1240	0.9668	0.8525	0.7310	0.5995	0.5100
315	5.0031	4.2731	3.9611	3.4713	3.0799	2.7385	2.4019	1.9364	1.6713	1.4486	1.2665	1.0508	0.8938
355	9.1381	8.0405	7.1603	6.3085	5.5454	4.8798	4.3155	3.6141	3.1717	2.7258	2.3560	1.9570	1.6424
400	16.3460	14.3211	12.8302	11.4472	10.0618	8.9604	7.8642	6.5225	5.6872	4.9513	4.2079	3.5074	3.0731
450	29.2141	25.8859	23.1367	20.5245	18.3050	15.9891	14.0735	11.8213	10.3121	8.9278	7.5931	6.3265	5.4216
500	48.5777	43.0958	38.3208	34.3368	29.8913	26.5409	23.5798	19.0048	16.4526	14.2221	12.2434	10.4745	8.6746
560	104.1878	90.0541	78.9130	69.1569	60.2662	52.6663	44.6843	37.1439	31.8064	26.8264	23.5155	19.6305	16.414
630			115.9194	103.1766	91.1936	79.6143	70.0504	58.1917	50.6604	43.1408	37.5024	31.5732	26.3924

**Type SBN/SBH/SBA**

Size of gear unit	Transmission ratio												
	6.3	7.1	8	9	10	11.2	12.5	14	16	18	20	22.4	25
110	0.0090	0.0077	0.0066	0.0052	0.0049	0.0039	0.0038	0.0030	0.0026	0.0020	0.0019	0.0017	0.0015
125	0.0169	0.0145	0.0125	0.0100	0.0095	0.0076	0.0073	0.0057	0.0049	0.0037	0.0036	0.0030	0.0025
140	0.0299	0.0253	0.0220	0.0174	0.0166	0.0132	0.0127	0.0103	0.0089	0.0068	0.0066	0.0051	0.0043
160	0.0549	0.0466	0.0407	0.0326	0.0312	0.0250	0.0242	0.0174	0.0150	0.0113	0.0109	0.0085	0.0071
180	0.0994	0.0845	0.0742	0.0591	0.0565	0.0450	0.0434	0.0321	0.0277	0.0210	0.0203	0.0154	0.0132
200	0.1633	0.1415	0.1228	0.0983	0.0939	0.0748	0.0721	0.0539	0.0473	0.0355	0.0344	0.0296	0.0244
225	0.3024	0.2530	0.2181	0.1749	0.1667	0.1344	0.1292	0.0974	0.0853	0.0645	0.0624	0.0496	0.0412
250	0.5403	0.4711	0.4111	0.3185	0.3042	0.2470	0.2380	0.1747	0.1517	0.1174	0.1138	0.0882	0.0736
280	0.9018	0.7849	0.6641	0.5260	0.5013	0.3937	0.3781	0.2941	0.2527	0.1944	0.1882	0.1461	0.1224
315	1.6963	1.4344	1.2139	0.9651	0.9213	0.7223	0.6947	0.5394	0.4621	0.3575	0.3466	0.2753	0.2284
355	2.9148	2.4747	2.1188	1.6496	1.5775	1.2259	1.1805	0.9374	0.8020	0.6291	0.6111	0.4685	0.3957
400	5.1242	4.2802	3.6704	2.9296	2.7935	2.1581	2.0724	1.6275	1.3936	1.0846	1.0506	0.8179	0.6895
450	9.0475	7.5773	6.4916	5.0463	4.7941	3.7423	3.5835	2.8159	2.3971	1.8429	1.7799	1.4377	1.1943
500	15.6595	13.2983	11.3664	9.7636	8.3816	7.2303	6.2735	5.2473	4.5506	3.9246	3.4127	2.9676	
560	28.5989	24.1245	20.5463	17.8981	15.4434	13.4355	11.6863	9.6167	8.2983	7.1766	6.2952	5.5222	
630	48.5326	42.2890	36.7028	31.7153	27.6493	24.0980	20.7686	17.4848	14.7742	12.8378	11.1630	9.7070	
710	80.7450	70.2130	61.0548	53.0911	46.1662	40.1445	34.9080	30.3550	26.3956	22.9528	19.9590	17.3555	
800	141.7000	132.4300	108.2000	102.0750	78.5200	74.0200	64.9800	54.1500	52.5700	40.4400	33.7010	26.0800	

**Type SCN/SCH/SCA**

Size of gear unit	Transmission ratio																		
	14	16	18	20	22.4	25	28	31.5	35.5	40	45	50	56	63	71	80	90	100	112
160	0.0174	0.0157	0.0129	0.0117	0.0098	0.0090	0.0078	0.0079	0.0056	0.0044	0.0041	0.0032	0.0027	0.0029	0.0025	0.0021	0.0021	0.0018	0.0015
180	0.0325	0.0291	0.0235	0.0214	0.0179	0.0165	0.0142	0.0144	0.0104	0.0080	0.0076	0.0060	0.0051	0.0055	0.0046	0.0039	0.0034	0.0034	0.0029
200	0.0553	0.0500	0.0403	0.0366	0.0305	0.0282	0.0243	0.0246	0.0177	0.0137	0.0129	0.0105	0.0088	0.0096	0.0080	0.0071	0.0060	0.0059	0.0047
225	0.0996	0.0903	0.0729	0.0657	0.0548	0.0505	0.0437	0.0436	0.0323	0.0261	0.0247	0.0176	0.0152	0.0158	0.0138	0.0115	0.0099	0.0098	0.0080
250	0.1826	0.1633	0.1381	0.1202	0.1002	0.0923	0.0800	0.0803	0.0589	0.0460	0.0434	0.0329	0.0280	0.0299	0.0256	0.0218	0.0188	0.0185	0.0148
280	0.3105	0.2784	0.2243	0.2035	0.1706	0.1570	0.1356	0.1361	0.0999	0.0779	0.0751	0.0566	0.0487	0.0512	0.0444	0.0372	0.0319	0.0317	0.0256
315	0.5831	0.5197	0.4214	0.3819	0.3179	0.2921	0.2503	0.2559	0.1841	0.1442	0.1358	0.1049	0.0897	0.0956	0.0823	0.0700	0.0608	0.0604	0.0486
355	1.0166	0.9124	0.7365	0.5718	0.5680	0.5229	0.4469	0.4596	0.3266	0.2542	0.2395	0.1857	0.1578	0.1694	0.1449	0.1246	0.1066	0.1059	0.0883
400	1.7520	1.5565	1.2424	1.1259	0.9546	0.8772	0.7499	0.7576	0.5444	0.4308	0.3942	0.3144	0.2666	0.2837	0.2423	0.2040	0.1761	0.1768	0.1448
450	3.1215	2.8049	2.2637	2.0636	1.7214	1.5810	1.3347	1.3679	1.0294	0.7653	0.7194	1.4814	1.2834	0.5138	0.4353	0.3723	0.3254	0.3229	0.2623
500	5.8534	5.2496	4.7588	4.2648	3.4638	3.1941	2.6824	2.7422	2.3254	2.0025	1.7257	0.5686	0.4785	1.0966	0.8836	0.7504	0.6464	0.5541	0.4496
560	10.4749	9.4324	8.5255	7.6012	6.1504	5.6342	4.6583	4.8222	4.0167	3.5039	3.0039	2.6135	2.2658	1.9339	1.5501	1.3115	1.1272	0.9613	0.7812
630	18.8051	16.7974	15.1032	13.6513	11.0804	10.1255	8.4253	8.6461	7.2564	6.2751	5.3475	4.5608	3.9203	3.3567	2.7032	2.2840	1.9413	1.6734	1.3761
710	34.5261	31.0451	28.3490	25.3529	20.5090	18.6702	15.6148	15.9983	13.5037	11.7029	9.9412	8.4943	7.2717	6.2523	5.2272	4.4962	3.8431	3.3761	2.7487
800	62.6566	56.4285	49.8868	45.3500	36.6775	33.6053	28.1079	28.7399	24.2636	20.8916	17.9747	15.3505	13.2479	11.3545	9.3779	8.0165	6.9272	5.9810	4.9460

**Type SDN/SDH/SDA**

Size of gear unit	Transmission ratio																	
	100	112	125	140	160	180	200	224	250	280	315	355	400	450	500	560	630	710
225		0.0058	0.0054	0.0045	0.0044	0.0035	0.0042	0.0034	0.0043	0.0037	0.0030	0.0025	0.0021	0.0021	0.0019	0.0015	0.0013	0.0013
250		0.0108	0.0099	0.0084	0.0082	0.0065	0.0079	0.0063	0.0080	0.0068	0.0054	0.0046	0.0039	0.0038	0.0034	0.0029	0.0024	0.0023
280		0.0185	0.0170	0.0144	0.0141	0.0114	0.0136	0.0110	0.0136	0.0118	0.0096	0.0081	0.0071	0.0068	0.0058	0.0046	0.0038	0.0039
315		0.0341	0.0312	0.0284	0.0277	0.0203	0.0268	0.0195	0.0247	0.0232	0.0167	0.0143	0.0120	0.0114	0.0096	0.0080	0.0064	0.0066
355		0.0619	0.0571	0.0484	0.0473	0.0359	0.0456	0.0346	0.0456	0.0394	0.0297	0.0254	0.0218	0.0217	0.0187	0.0149	0.0126	0.0122
400		0.1034	0.0954	0.0818	0.0798	0.0615	0.0767	0.0591	0.0755	0.0660	0.0507	0.0441	0.0369	0.0369	0.0317	0.0257	0.0216	0.0210
450		0.1897	0.1748	0.1503	0.1467	0.1135	0.1411	0.1091	0.1395	0.1225	0.0944	0.0815	0.0693	0.0692	0.0602	0.0485	0.0408	0.0396
500	0.4291	0.3349	0.3019	0.2767	0.3020	0.2349	0.1966	0.1842	0.1396	0.1317	0.1243	0.1183	0.1130	0.1086	0.1054	0.0879	0.0738	0.0723
560	0.7323	0.5804	0.5152	0.4722	0.5070	0.4030	0.3363	0.3146	0.2362	0.2223	0.2084	0.1975	0.1884	0.1804	0.1741	0.1426	0.1207	0.1172
630	1.3285	1.0482	0.9351	0.8599	0.9184	0.7254	0.6019	0.5608	0.4320	0.0457	0.3832	0.3645	0.3477	0.3340	0.3220	0.2615	0.2181	0.2118
710	2.36																	

**Inertia, GD<sup>2</sup> [kgm<sup>2</sup>]  
relative to the input shaft**

**Type KBN/KBH/KBA**

Size of gear unit	Transmission ratio										
	6.3	7.1	8	9	10	11.2	12.5	14	16	18	20
80	0.0025	0.0025	0.0024	0.0020	0.0016	0.0014	0.0012	0.0010	0.0009	0.0008	0.0007
90	0.0050	0.0047	0.0044	0.0036	0.0029	0.0024	0.0020	0.0017	0.0014	0.0012	0.0011
100	0.0073	0.0070	0.0068	0.0055	0.0046	0.0038	0.0032	0.0027	0.0023	0.0020	0.0018
110	0.0110	0.0106	0.0103	0.0083	0.0068	0.0056	0.0046	0.0039	0.0034	0.0028	0.0024
125	0.0205	0.0197	0.0190	0.0155	0.0128	0.0105	0.0087	0.0072	0.0061	0.0052	0.0046
140	0.0383	0.0368	0.0354	0.0288	0.0236	0.0193	0.0160	0.0134	0.0112	0.0095	0.0082
160	0.0696	0.0667	0.0645	0.0522	0.0429	0.0350	0.0290	0.0241	0.0199	0.0169	0.0148
180	0.1237	0.1190	0.1149	0.0939	0.0776	0.0642	0.0538	0.0453	0.0378	0.0323	0.0286
200	0.2235	0.2155	0.2087	0.1698	0.1411	0.1172	0.0982	0.0831	0.0695	0.0599	0.0531
225	0.3932	0.3782	0.3655	0.2966	0.2442	0.2010	0.1666	0.1400	0.1169	0.0992	0.0873
250	0.6985	0.6750	0.6526	0.5257	0.4290	0.3502	0.2878	0.2378	0.1994	0.1658	0.1435
280	1.1869	1.1473	1.1087	0.8920	0.7220	0.5894	0.4798	0.3935	0.3270	0.2696	0.2327
315	2.1780	2.1049	2.0365	1.6315	1.3242	1.0811	0.8748	0.7174	0.5946	0.4869	0.4168
355	3.9871	3.8329	3.7203	2.9970	2.4383	1.9923	1.6328	1.3515	1.1319	0.9386	0.8113
400	7.0063	6.7242	6.5116	5.2455	4.2737	3.4949	2.8625	2.3740	1.9920	1.6536	1.4315
450	13.4583	13.0192	12.6252	10.1628	8.2825	6.7342	5.5142	4.5677	3.8215	3.2505	2.7662
500	24.6957	23.8791	23.2011	18.5713	15.0635	12.1569	9.8988	8.0856	6.6975	5.5200	
560	43.8212	42.5667	41.4512	32.9657	26.7468	21.5321	17.3616	14.0481	11.5030	9.5517	

**Type KCN/KCH/KCA**

Size of gear unit	Transmission ratio																	
	14	16	18	20	22.4	25	28	31.5	35.5	40	45	50	56	63	71	80	90	100
110	0.0059	0.0056	0.0043	0.0041	0.0039	0.0031	0.0036	0.0029	0.0024	0.0020	0.0016	0.0014	0.0012	0.0010	0.0009	0.0009	0.0008	0.0007
125	0.0103	0.0097	0.0073	0.0069	0.0066	0.0052	0.0061	0.0048	0.0039	0.0032	0.0026	0.0022	0.0018	0.0015	0.0013	0.0012	0.0011	0.0010
140	0.0180	0.0170	0.0127	0.0121	0.0114	0.0091	0.0107	0.0085	0.0069	0.0056	0.0047	0.0039	0.0032	0.0027	0.0023	0.0023	0.0020	0.0018
160	0.0283	0.0266	0.0201	0.0189	0.0181	0.0155	0.0166	0.0129	0.0106	0.0086	0.0070	0.0058	0.0048	0.0040	0.0034	0.0033	0.0029	0.0025
180	0.0516	0.0483	0.0369	0.0348	0.0321	0.0259	0.0304	0.0238	0.0194	0.0158	0.0130	0.0107	0.0089	0.0073	0.0061	0.0061	0.0053	0.0046
200	0.0930	0.0877	0.0749	0.0627	0.0599	0.0472	0.0553	0.0436	0.0354	0.0287	0.0235	0.0193	0.0159	0.0134	0.0111	0.0110	0.0095	0.0082
225	0.1686	0.1594	0.1208	0.1136	0.1082	0.0854	0.0995	0.0785	0.0638	0.0517	0.0424	0.0346	0.0287	0.0239	0.0197	0.0196	0.0167	0.0146
250	0.3007	0.2815	0.2140	0.2019	0.1918	0.1526	0.1767	0.1406	0.1145	0.0936	0.0774	0.0641	0.0536	0.0452	0.0377	0.0375	0.0321	0.0284
280	0.5381	0.5060	0.3881	0.3675	0.3504	0.2793	0.3238	0.2583	0.2093	0.1703	0.1415	0.1175	0.0984	0.0833	0.0696	0.0692	0.0598	0.0529
315	0.9763	0.8792	0.6969	0.6575	0.6249	0.4928	0.5790	0.4565	0.3720	0.3019	0.2484	0.2044	0.1693	0.1421	0.1186	0.1179	0.0999	0.0879
355	1.7275	1.6234	1.2372	1.1725	1.1155	0.8762	1.0353	0.8129	0.6597	0.5313	0.4335	0.3538	0.2907	0.2400	0.2012	0.2001	0.1663	0.1439
400	2.9719	2.7765	2.1019	1.9853	1.8875	1.4265	1.7360	1.3624	1.1064	0.8902	0.7205	0.5883	0.4790	0.3928	0.3264	0.3243	0.2675	0.2309
450	5.3823	5.0658	3.8302	3.6301	3.4523	2.6776	3.1827	2.4645	2.0058	1.6071	1.3045	1.0654	0.8624	0.7076	0.5870	0.5830	0.4777	0.4093
500	10.1081	9.5043	7.0135	6.5195	6.4334	4.8493	5.7118	4.4923	3.6492	2.9403	2.3928	1.9561	1.6042	1.3290	1.1141	1.1141	0.9246	0.7999
560	18.0444	17.0019	12.9050	12.1708	11.3425	8.5222	10.0144	7.8806	6.4023	5.1584	4.2038	3.4391	2.8185	2.3393	1.9647	1.6321	1.4140	
630	34.1775	32.1698	24.4756	23.0237	22.1193	16.6199	19.6851	15.4510	12.4880	10.0535	8.1947	6.6642	5.4589	4.5242	3.7872	3.2234	2.7443	
710	65.1838	61.7030	46.0068	44.0107	41.6337	31.7949	37.0690	29.3624	23.4664	18.7828	15.2333	12.2922	10.0057	8.1699	6.7638	5.5724	4.7764	
800	116.5060	110.2779	83.7362	79.1994	75.2618	56.2157	67.3242	52.3714	41.8444	33.2792	26.9985	21.7329	17.5200	14.1730	11.6013	9.6294	8.2563	

**Type KCN/KCH/KCA**

Size of gear unit	Transmission ratio																	
	100	112	125	140	160	180	200	224	250	280	315	355	400	450	500	560	630	710
160	0.0039	0.0031	0.0029	0.0033	0.0026	0.0031	0.0025	0.0017	0.0016	0.0016	0.0016	0.0016	0.0015	0.0015	0.0015	0.0013	0.0011	0.0010
180	0.0050	0.0040	0.0036	0.0039	0.0031	0.0035	0.0028	0.0019	0.0018	0.0018	0.0017	0.0017	0.0016	0.0016	0.0016	0.0013	0.0011	0.0011
200	0.0070	0.0056	0.0049	0.0050	0.0040	0.0042	0.0034	0.0024	0.0022	0.0021	0.0020	0.0019	0.0018	0.0018	0.0017	0.0015	0.0012	0.0012
225	0.0129	0.0102	0.0090	0.0092	0.0073	0.0078	0.0062	0.0043	0.0040	0.0038	0.0036	0.0034	0.0033	0.0033	0.0032	0.0027	0.0023	0.0022
250	0.0226	0.0181	0.0160	0.0161	0.0131	0.0138	0.0112	0.0078	0.0073	0.0069	0.0065	0.0062	0.0060	0.0060	0.0059	0.0046	0.0039	0.0031
280	0.0431	0.0324	0.0285	0.0313	0.0231	0.0270	0.0197	0.0134	0.0124	0.0117	0.0110	0.0105	0.0101	0.0101	0.0098	0.0082	0.0066	0.0064
315	0.0743	0.0572	0.0505	0.0533	0.0406	0.0453	0.0344	0.0242	0.0225	0.0211	0.0199	0.0190	0.0183	0.0182	0.0178	0.0142	0.0121	0.0118
355	0.1297	0.1009	0.0887	0.0915	0.0708	0.0771	0.0594	0.0419	0.0387	0.0361	0.0341	0.0326	0.0312	0.0312	0.0303	0.0245	0.0207	0.0202
400	0.2258	0.1758	0.1555	0.1611	0.1248	0.1367	0.1057	0.0756	0.0703	0.0659	0.0625	0.0598	0.0575	0.0574	0.0560	0.0451	0.0381	0.0373
450	0.4046	0.3157	0.2793	0.2877	0.2237	0.2431	0.1886	0.1340	0.1243	0.1162	0.1100	0.1052	0.1009	0.1008	0.0981	0.0846	0.0692	0.0678
500	0.8270	0.6557	0.5589	0.4920	0.4925	0.3923	0.3279	0.3006	0.2308	0.2133	0.1992	0.1882	0.1796	0.1720	0.1670	0.1372	0.1165	0.1139
560	1.4702	1.1598	0.9904	0.8731	0.8846	0.6987	0.5809	0.5331	0.4186	0.3880	0.3632	0.3440	0.3290	0.3157	0.3070	0.2497	0.2086	0.2039
630	2.7618	2.1947	1.8587	1.6236	1.6038	1.2830	1.0650	0.9693	0.7554	0.6942	0.6460	0.6086	0.5791	0.5565	0.5374	0.4364	0.3685	0.3593
710	5.0979	4.0413	3.4298	2.9620	2.8973	2.3087	1.9089	1.7251	1.3437	1.2261	1.1346	1.0612	1.0049	0.9573	0.9254	0.7526	0.6377	0.6201
800	9.1156	7.2374	6.0509	5.2156	5.0515	4.0376	3.3351	3.0060	2.3461	2.1355	1.9670	1.8331	1.7302	1.6513	1.5964	1.3147	1.1007	1.0698

Conversion GD<sup>2</sup> into WR<sup>2</sup> : 1kgm<sup>2</sup> = 5.93 lbf<sup>2</sup> i.e. multiply listed figures with 5.93.

**Water cooling/Cooling coils  
Dimensions for connections**

**SAN**

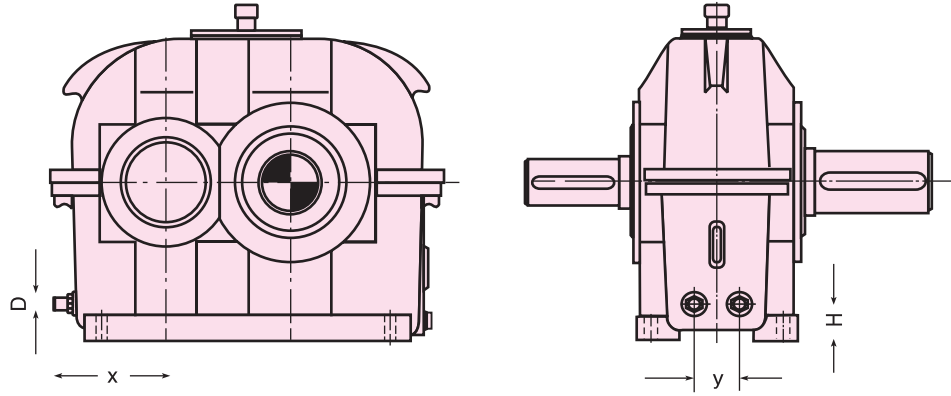

**SBN / SBH**

Type SBA  
Dimensions  
on request

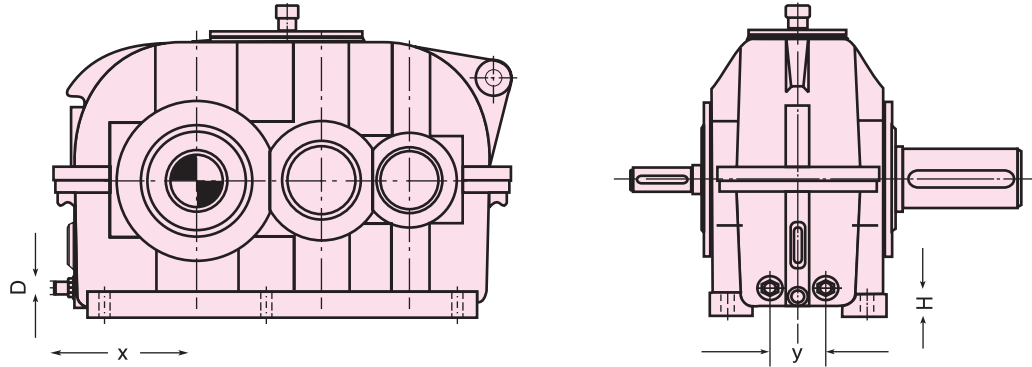

**SCN / SCH**

Type SCA  
Dimensions  
on request

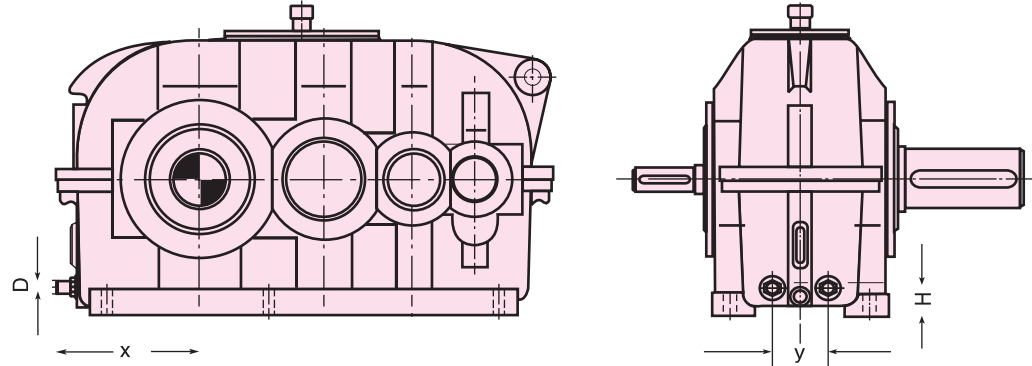

Type of gear unit	Dimen- sions	Size of gear unit																					
		80	90	100	110	125	140	160	180	200	225	250	280	315	355	400	450	500	560	630	710	800	
SAN	D	On request			R 1/2"							R 3/4"					On request						
	H	On request			45	50			60	70				100		130		On request					
	x	135		145	155	170	180	200	215	235	255	280	305	335	375	405	445	480	On request				
	y	40		55			80				100				150		200		On request				
SBN/SBH	D	R 3/8"				R 1/2"					R 3/4"					On request							
	H	37			40		45			55		65		70		80		105		On request			
	x	160		180	195	215	230	250	270	295	325	350	380	425	470	515	570	630	On request				
SCN/SCH	D	R 3/8"				R 1/2"					R 3/4"					On request							
	H	40			45		55			65		70		80		105		On request					
	x	215		230	250	270	295	325	350	380	425	470	515	570	630	On request							
	y	70		100				170				230				On request							

Thermal capacities for gear units with built-in cooling coil according to the values in the power tables (see also calculation example).

If desired an oil pump and external oil cooler can be offered instead of a cooling coil.

The values given in the power tables apply for a maximum inlet temperature of 20°C. At higher inlet temperatures, please inquire.

## Water cooling/Cooling coils Dimensions for connections

### KBN/KBH

Type KBA  
Dimensions  
on request

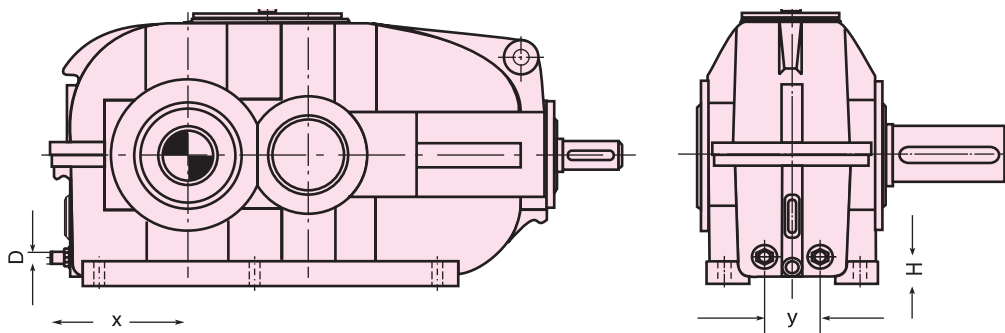

### KCN/KCH

Type KCA  
Dimensions  
on request

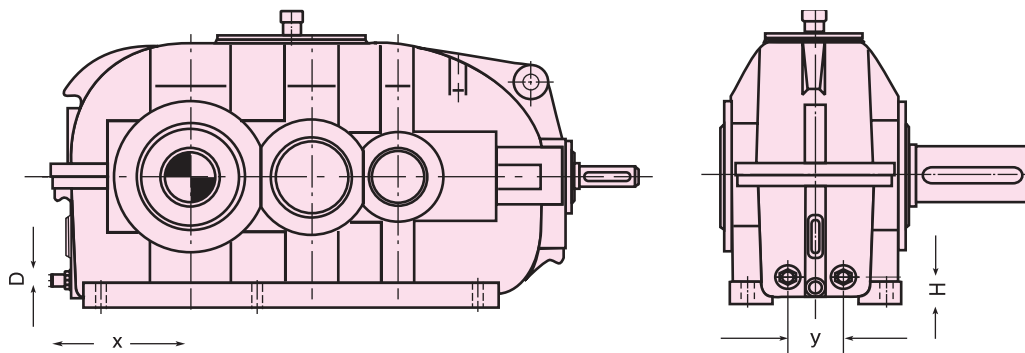

## Connections

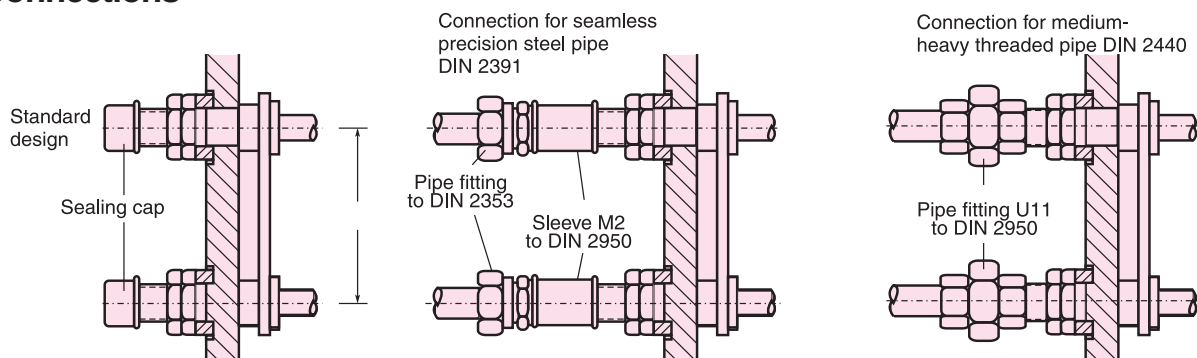

Type of gear unit	Dimen- sions	Size of gear unit																On request																
		80	90	100	110	125	140	160	180	200	225	250	280	315	355	400	450		500	560	630	710	800											
KBN / KBH	D	R 1/2"										R 3/4"						On request																
	H	37										40		45		60			65		70		80		105									
	x	160		180		195		215		230		250		270		295			325		350		380		425		470		515		570		630	
	y	56				70				100				170					230															
KCN / KCH	D	R 1/2"										R 3/4"						On request																
	H	40										45		60		65			70		80		105											
	x	215		230		250		270		295		325		350		380			425		470		515		570		630							
	y	70				100				170				230																				

Built-in cooling coils of normal design suitable for fresh water .  
(mains and recirculated water and water not chemically polluted)  
Sea water and brackish water require cooling coils of special  
design.  
Maximum permissible pressure of water : 10 bar.  
The direction of flow of the water is optional  
Contact thermometers and water control valves can also be  
offered.

Missing data on request.

# Backstops for helical gear units

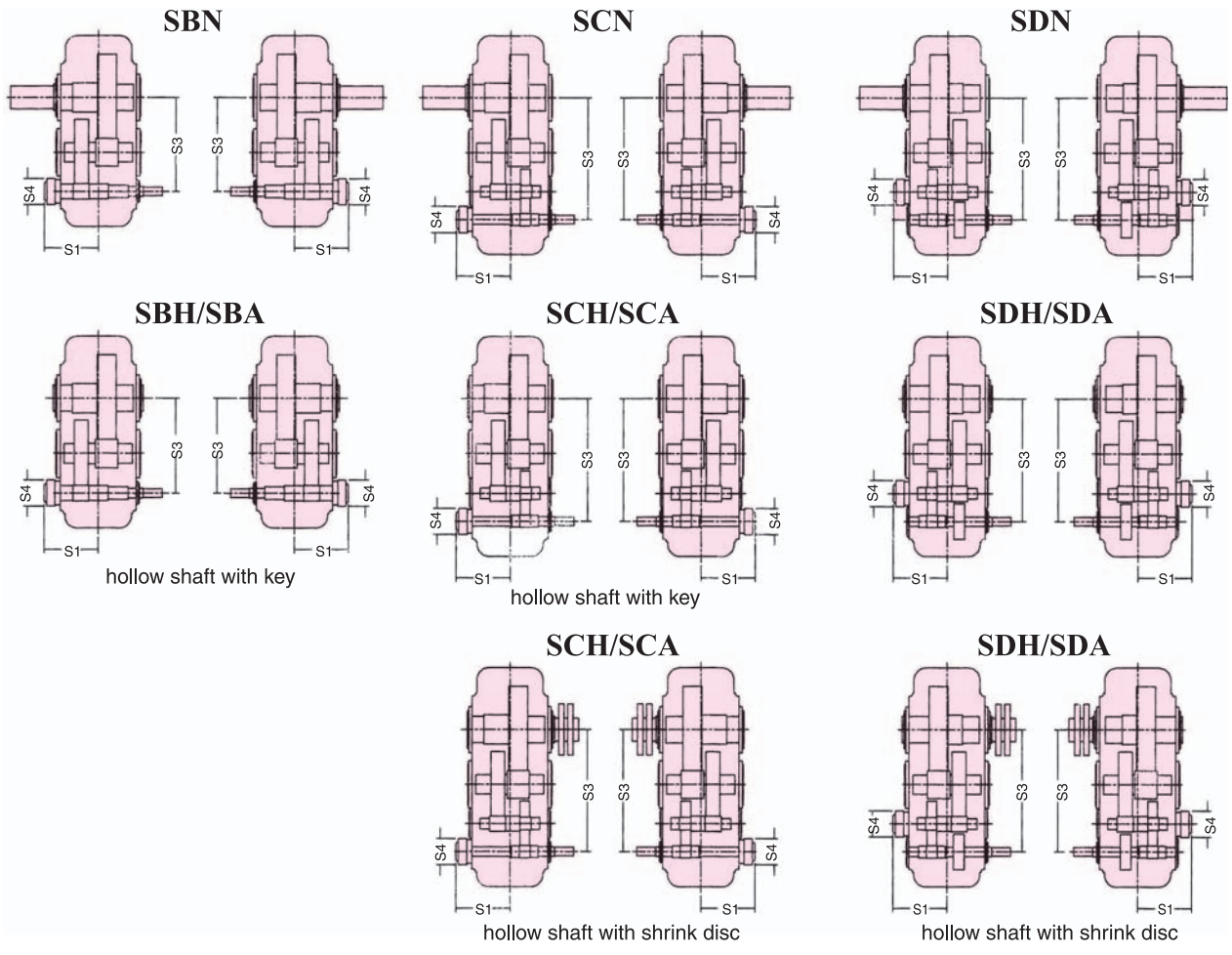

Gear unit types SBN/SBH/SBA						Gear unit types SCN/SCH/SCA					Gear unit types SDN/SDH/SDA							
Gear unit size	Dimensions [mm]					Gear unit size	Dimensions [mm]					Gear unit size	Dimensions [mm]					
	$S_3$	$i_N \leq 10$		$i_N \geq 10$			$S_3$	$i_N \leq 35.5$		$i_N > 35.5$			$S_2$	$S_3$	$i_N \leq 180$		$i_N > 180$	
	$S_1$	$S_4$	$S_1$	$S_4$		$S_1$	$S_4$	$S_1$	$S_4$		$S_1$	$S_4$	$S_1$	$S_4$	$S_1$	$S_4$		
110	190	175	105	175	105	160	270	210	105	210	105	225	110	385	255	165	245	165
125	215	190	105	190	105	180	305	220	105	220	105	250	125	430	295	175	280	175
140	240	195	125	195	125	200	340	235	105	235	105	280	140	480	315	200	310	185
160	270	210	135	210	135	225	385	243	132	241	105	315	160	540	340	220	340	220
180	305	220	145	220	145	250	430	266	132	266	132	355	180	605	375	265	375	265
200	340	245	165	235	165	280	480	293	150	281	132	400	200	680	415	285	400	285
225	385	270	175	255	175	315	540	328	175	313	150	450	225	765	455	335	445	335
250	430	300	200	295	185	355	605	348	190	348	175	500	250	855	555	355	555	355
280	480	330	220	315	210	400	680	393	210	376	190	560	280	960	600	410	600	410
315	540	355	230	340	230	450	765	425	210	403	190	630	315	1080	640	420	640	420
355	605	390	265	375	265							710	355	1210	695	480	695	480
400	680	425	290	415	285	500	855	525	245	515	210	800	400	1360	735	520	735	520
450	765	470	320	455	300	560	960	580	290	565	245							
500	855	560	410	535	375	630	1080	620	310	620	290							
560	960	600	420	595	420	710	1210	657	400	665	310							
630	1080	660	430	640	420	800	1360	707	400	705	310							
710	1210	695	480	695	480													
800	1360	805	520	735	520													

Note : Gear unit type SDN, SDH and SDA - the input shaft is situated at a distance of  $h-h_1$  below the joint. (See dimensional drawing SDN/SDH.)

## Backstops for helical gear units

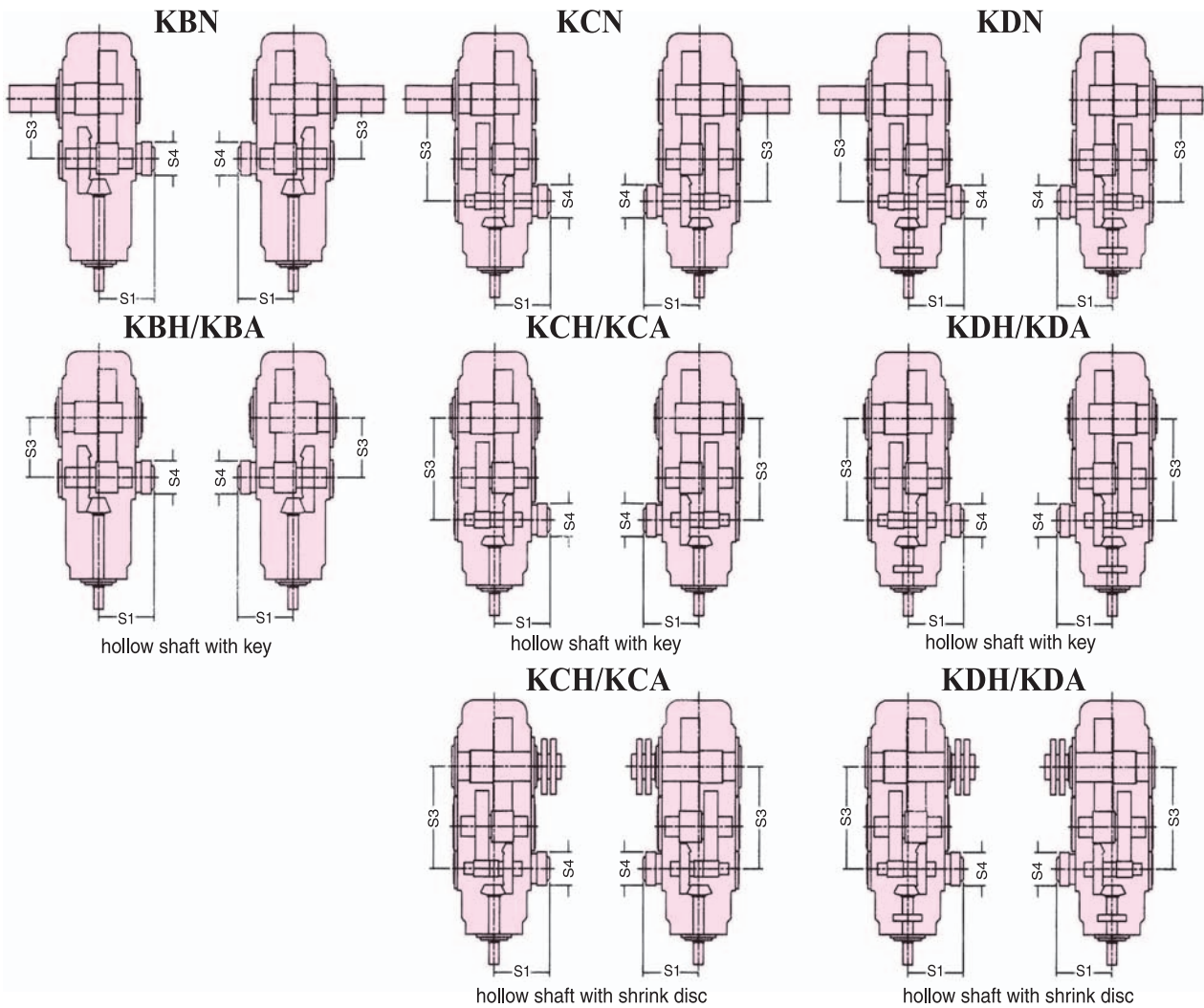

Gear unit types KBN/KBH/KBA				Gear unit types KCN/KCH/KCA						Gear unit types KDN/KDH/KDA			
Size of gear unit	Dimensions [mm]			Size of gear unit	Dimensions [mm]					Size of gear unit	Dimensions [mm]		
	S <sub>4</sub>	S <sub>1</sub>	S <sub>3</sub>		S <sub>3</sub>	S <sub>1</sub> <sup>i<sub>N</sub> ≤ 25</sup>	S <sub>4</sub> <sup>i<sub>N</sub> &gt; 25</sup>	S <sub>1</sub> <sup>i<sub>N</sub> &gt; 25</sup>	S <sub>4</sub>		S <sub>3</sub>	S <sub>1</sub>	S <sub>4</sub>
80	105	150	80	110	190	175	105	175	105	160	270	210	125
90	105	160	90	125	215	190	105	190	105	180	305	220	135
100	105	170	100	140	240	195	105	195	105	200	340	235	145
110	125	175	110	160	270	210	125	210	125	225	385	245	165
125	135	190	125	180	305	220	135	220	135	250	430	280	175
140	145	195	140	200	340	235	145	235	145	280	480	310	185
160	165	220	160	225	385	255	165	245	165	315	540	340	220
180	175	245	180	250	430	295	175	280	175	355	605	375	265
200	200	265	200	280	480	315	200	310	185	400	680	400	285
225	220	275	225	315	540	340	220	340	220	450	765	445	335
250	265	315	250	355	605	375	265	375	265	500	855	540	355
280	285	345	280	400	680	415	285	400	285	560	960	575	375
315	335	380	315	450	765	455	335	445	335	630	1080	635	420
355	355	415	355							710	1210	675	480
400	410	440	400	500	855	555	355	540	355	800	1360	735	520
450	420	475	450	560	960	600	410	575	375				
500	480	580	500	630	1080	640	420	635	420				
560	520	620	560	710	1210	695	480	675	480				
				800	1360	735	520	735	520				

Backstops for types KBH and KBA with shrink disc on request.

## National Branches :

### Ahmedabad

Tel: +91 79 26406683/26406684/26406685  
 Fax: +91 79 2640 1363  
 Email : salesahd@elecon.com

### Bangalore

Tel: +91 80-25290082, 25250219, 25252925  
 Fax: +91 80-25251834  
 Email : salesbgl@elecon.com

### Bilaspur

Tel: +91 7752 247723 / 247625  
 Fax: +91 7752 247720  
 Email : salesbil@elecon.com

### Chennai

Tel: +91 44 24349237/24349497/24322455  
 Fax: +91 44 2434 9643  
 Email : saleschn@elecon.com

### Indore

Tele Fax: + 91 731 257 6100  
 Email : salesindr@elecon.com

### Kolkata

Tel: +91 33 2476 1861 / 2476 0876  
 Fax: +91 33 2476 1831  
 Email : saleskol@elecon.com

### Madurai

Tel: +91 4549 293488  
 Email : salesmadu@elecon.com

### Nagpur

Tel: +91 712 6642600 / 6642 601  
 Fax: +91 712 6642 622  
 Email : salesnag@elecon.com

### Mumbai

Tel: +91 22 22821315/22820725/22821365  
 Fax: +91 22 2287 0791  
 Email : salesbom@elecon.com

### New Delhi

Tel: +91 11 2341 4340 / 2341 4341  
 Fax: +91 11 2370 9046  
 Email : salesdel@elecon.com

### Pune

Tel: +91 20 4019 1400  
 Fax: +91 20 4019 1411  
 Email : salespune@elecon.com

### Raipur

Tele Fax: +91 771 2259 321 /23/24/30  
 Email : salesrai@elecon.com

### Hyderabad

Tele Fax: +91 40 64561199  
 Email : salessec@elecon.com

### Vadodara

Tel: +91 265 2313 670  
 Tele Fax: 91 265 2312 972 / 2312 980  
 Email : salesvad@elecon.com

### Vallabh Vidyanagar

Tel. +91 02692-231125 / 227559/227549/ 227560  
 E mail : salesvvn@elecon.com

## International Network :

### MIDDLE EAST :

**ELECON MIDDLE EAST FZCO, Dubai**  
 Phone : +97 146 091 424, +97 146 091 425  
 Fax : +97 146 091 426  
 E-mail : salesme@elecon.com

### FAR EAST :

**ELECON SINGAPORE PTE. LTD.**  
 Phone : +65 622 782 58  
 Fax : +65 622 789 42  
 E-mail : salesap@elecon.com



### AUSTRALIA

Radicon Transmission  
 ( Australia) Pty. Ltd.  
 Tel: +61 488 054 028  
 Fax: +61 295 213 522  
 salesap@elecon.com  
 www.radicon.com

### UNITED KINGDOM

Radicon Transmission UK LTD.  
 Tel: +44 (0)1484 465800  
 Fax: +44 (0)1484 465801  
 sales@radicon.com  
 www.radicon.com

### THAILAND

Radicon Transmission Thailand Ltd.  
 Tel : +66 38 459 044  
 Fax: +66 38 213 655  
 salesap@elecon.com  
 www.radicon.com

### UNITED STATES OF AMERICA

RADICON USA  
 Tel. 1-847-593-9910  
 Fax. :1-847-593-9950  
 salesusa@radicon.com  
 www.radicon.com

### MIDDLE EAST

Radicon Transmission FZE  
 Tel: + 97165527950  
 Fax: + 97165527951  
 radicon@eim.ae  
 www.radicon.com



### SWEDEN

AB Benzlers  
 Tel: + 46 42 18 68 00  
 Fax: + 46 42 21 88 03  
 info@benzlers.com  
 www.benzlers.com

### NETHERLANDS

Benzler-TBA BV  
 Tel : +31 077 324 5900  
 Fax: +31 077 324 5901  
 mail@benzlers.com  
 www.benzlers.com

### GERMANY

Benzler Antriebstechnik  
 Gmbh  
 Tel: +49 0800 350 4000  
 Fax: +49 0800 350 4001  
 mail@benzlers.com  
 www.benzlers.com

### FINLAND

O.Y. Benzler AB  
 Tel: +358 9 340 1716  
 Fax: +358 10 296 2072  
 info@benzlers.com  
 www.benzlers.com

### DENMARK

Benzler Transmission A/S  
 Tel: +45 36 34 0300  
 info@benzlers.com  
 www.benzlers.com

