

**ELECON**

**EPEX SINGLE SHAFT EXTRUDER GEAR UNITS**

**265/3**

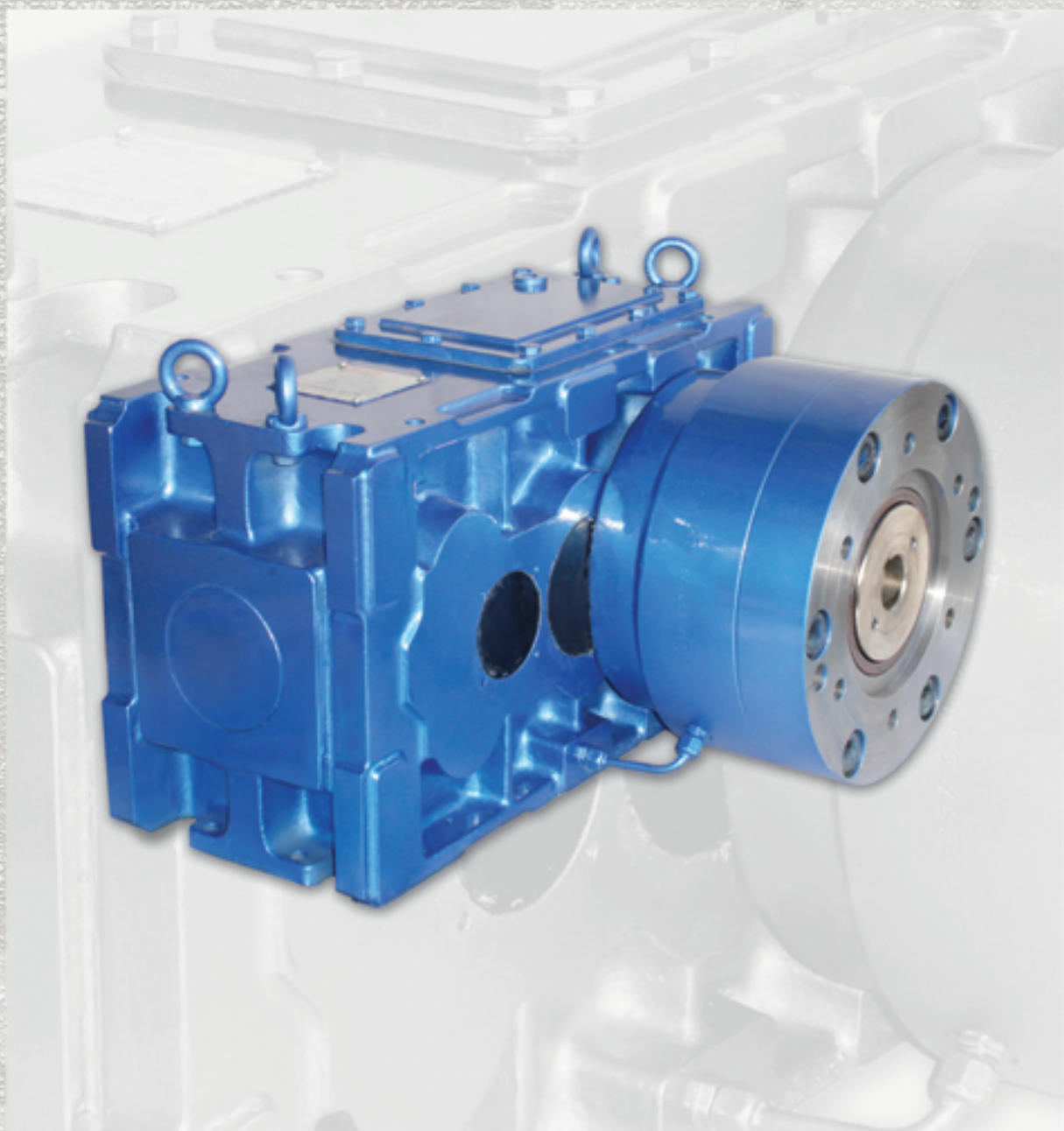

**ELECON** 

*Always a step ahead in technology*

---

# EPEX

## - Modular Single Shaft Extruder Gear Units

<b>Contents</b>	<b>page</b>
General description	1
<hr/>	
Selection of thrust bearing	2
Diagrams of life duration	3-4
Dimension sheets Thrust Bearing	5-7
<hr/>	
Selection of Gear unit	8
Combination Gear Unit-Thrust Bearing Housing, Example	9
Exact Ratio	10
Output Torques / Power Ratings	11-12
Thermal capacities	13
Dimension sheets Gear Units	14-18
Dimension sheet Cooling Coil	19
<hr/>	
Check-list	20
<hr/>	

# ELECON

## Modular Single Shaft Extruder Gear Units

### General Points

Continuously working single-screw extruder presses or single screw extruders, on account of their materials processing technology and construction demands on the driver assembly:

- To be capable of transmitting the high torques for pressurising and plasticising moulding materials and synthetics required for fibre line production and secondly
- Capability of absorbing the high thrust load induced by the process.

While the first point determines gearbox size and ratio, the axial forces and desired bearing life govern the axial bearing and its housing

In order to obtain an economical drive assembly which is adapted in the best possible way to the materials processing technical demands, Elecon has developed an

### Extruder Gear Modular-Series EPEX

The Elecon extruder gear modular consists of a combination of **Gear units** (of different EP Series ) and flanged **axial bearing housing** for the take-up of axial self-aligning roller bearings of different load capacities.

According to their functions both these assemblies are to be designed independently of each other.

#### Selection :

- Gearbox : page 8
- Axial bearing page 2

From the combination of both assemblies the Elecon single shaft extruder gear is produced.  
Combination possibilities : Page 9

#### Assembly :

**Gearboxes** : Elecon EP-Series (as per leaflet no.264) The standard gear range of the Elecon EP Series includes single to 4 stage helical and bevel helical gearboxes in 19 sizes with ratios from 1.25:1 to 710:1

**Gears** : helical gears, low noise, casehardened and ground. Profile correction for optimum load response. Spiral bevel gears Klingelberg, case hardened and ground.

**Casing** : casing of great robustness in grey cast iron, designed according to the latest acoustic and heat transfer technologies.

**Lubrication** : Gear and antifriction bearings are splash lubricated as standard. Force feed lubrication systems are available as standard options.

**Cooling** : as standard option built in cooling coil. Combined cooling and lubricating system are also available on request.

The Elecon quality assurance system in accordance with ISO 9001 registration no.041004756 Rw TUV CERT guarantees a uniformly high standard.

#### Assembly :

#### Axial bearing housing with self-aligning roller bearings

Axial bearing housing : Spheroidal graphite cast iron Extruder flange may be customized to suit client's requirements Versions of the output shafts requirements. Axial screw forces are contained in the axial bearings of 293...E and 294...E series.

Further axial bearing versions are possible upon consultation with our design office.

*Gear box system Elecon EP series (two to three series)*

*Axial bearing housing with self aligning roller bearings*

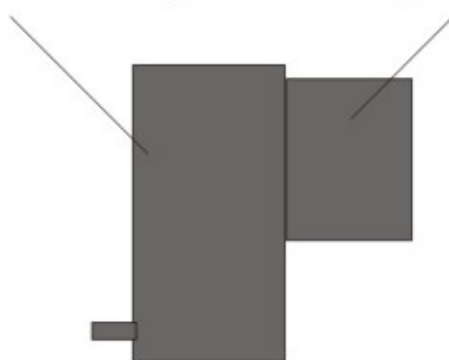

**Axial bearing** function of  
screw diameter  
screw thrust load  
screw speed  
bearing life

## Selection of the thrust bearing

- The thrust pressure  $F_{ax}$  [kN] of the extruder screw (has to be specified by the extruder manufacturer) For an approximate calculation by neglecting possible supplementary forces of technological nature for specific to extruders, it is sufficient to suppose that :

$$F_{ax} = \pi \cdot \frac{D^2 \cdot s}{4 \cdot 10000} \cdot Pa$$

- The necessary dynamical bearing capacity of the thrust bearing  $C_{requ}$  [kN]

$$C_{requ} = f_d \cdot F_{ax} \cdot \left( \frac{L_h \cdot 60 \cdot n_s}{10^6} \right)^{\frac{3}{10}}$$

$$C_{requ} < C_{selection \ table}$$

### Rating example

Screw diameter :  $D_s = 80$  mm  
 Working pressure :  $P_a = 500$  bar  
 Speed of the extruder screw :  $n_s = 100$  min<sup>-1</sup>  
 Thrust bearing life duration :  $L_h = 20\ 000$  h

Determination of the axial force of the extruder screw :

$$F_{ax} = \pi \frac{D^2 s}{4 \cdot 10000} \cdot Pa \text{ [kN]}$$

$$F_{ax} = \pi \frac{80^2}{4 \cdot 10000} \cdot 500 = 251 \text{ kN}$$

### Selection

Choice from the dimension sheet Thrust bearing

Frame size 424  $\varnothing$   $F_{ax}$  permissible = 262 kN >  $F_{ax}$  actual = 251 kN  
 or rating by calculation using the dynamic bearing capacity of the thrust bearing :

$$C_{requ} = 1.06 \cdot 251 \cdot \left( 20000 \cdot 60 \cdot \frac{100}{1000000} \right)^{\frac{3}{10}} = 1119 \text{ kN}$$

Choice of the thrust bearing from the table (page 3) size 29424 E

$$C_{requ} = 1119 \text{ kN} < C_{actual} = 1170 \text{ kN}$$

$n_s$  [min<sup>-1</sup>] Speed of the extruder screw  
 $f_d$  Factor for sense of rotation (max=1.06)

$D_s$  [mm] Extruder screw diameter

$P_a$  [bar] Working pressure

$F_{ax}$  [kN] Thrust pressure from the extruder screw

$L_h$  [h] Bearing life duration

$C_{requ}$  [kN] Required dynamic bearing capacity of the thrust bearing

$C_{selection \ table}$  [kN] Dynamic bearing capacity of the thrust bearing according to the selection table

If the required gearbox / thrust bearing combination cannot be found in the selection table "Combination Gear Unit - Thrust Bearing" (page 9) please proceed as follows :

- for a **smaller** thrust bearing use the smallest bearing housing relative to the chosen reducer size.
- for a **larger** thrust bearing please contact your local engineer at the Elecon sales office.

Requested thrust bearing life duration

20 000 h

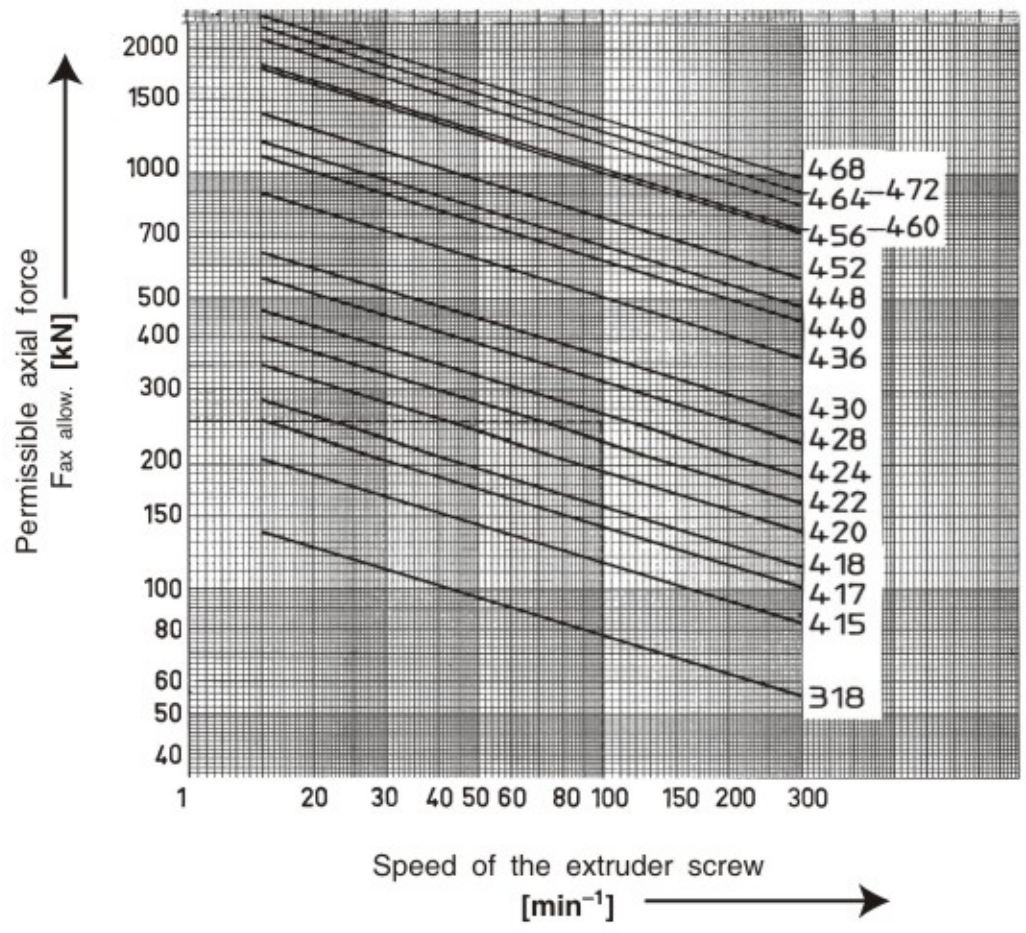

30 000 h

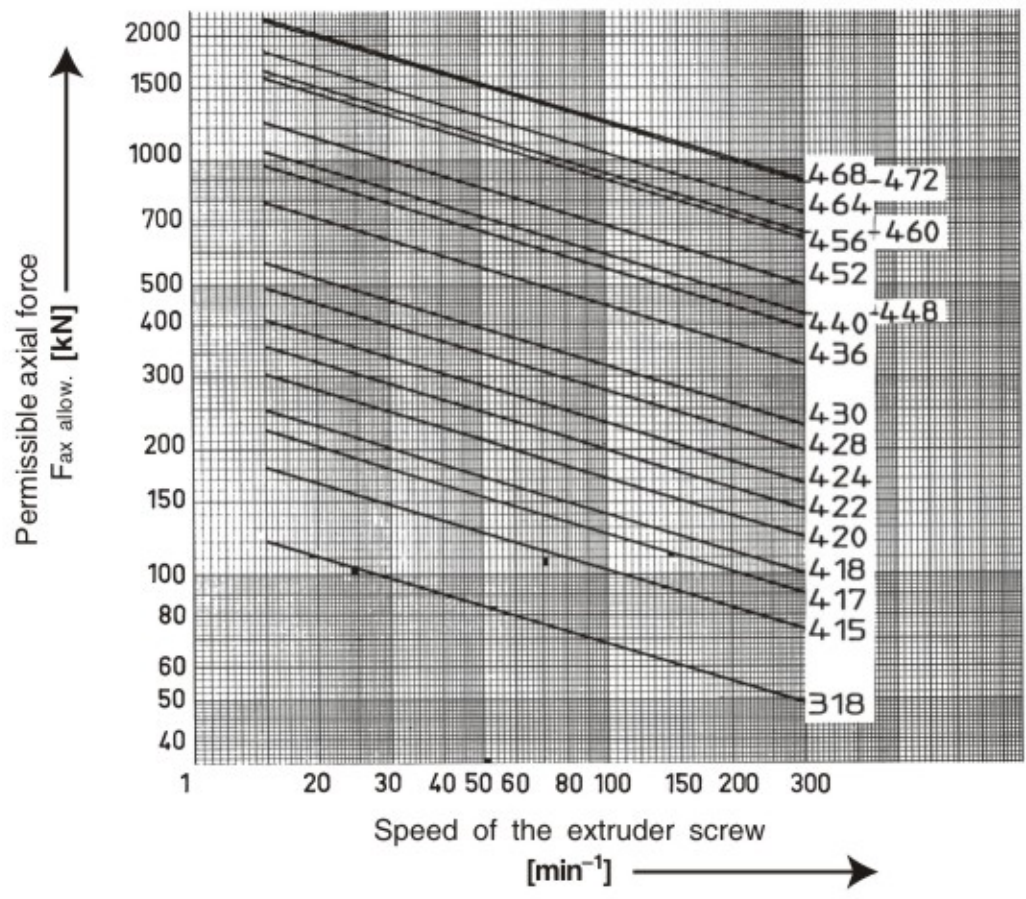

# Requested thrust bearing life duration

**40 000 h**

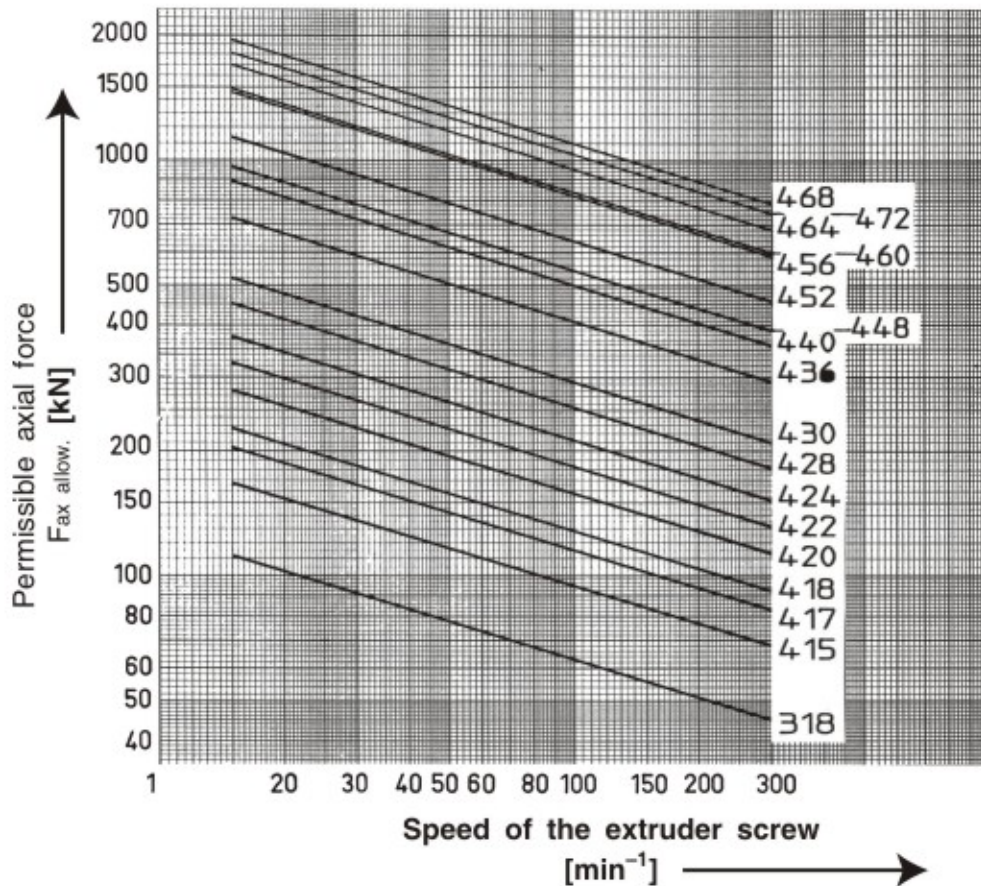

**50 000 h**

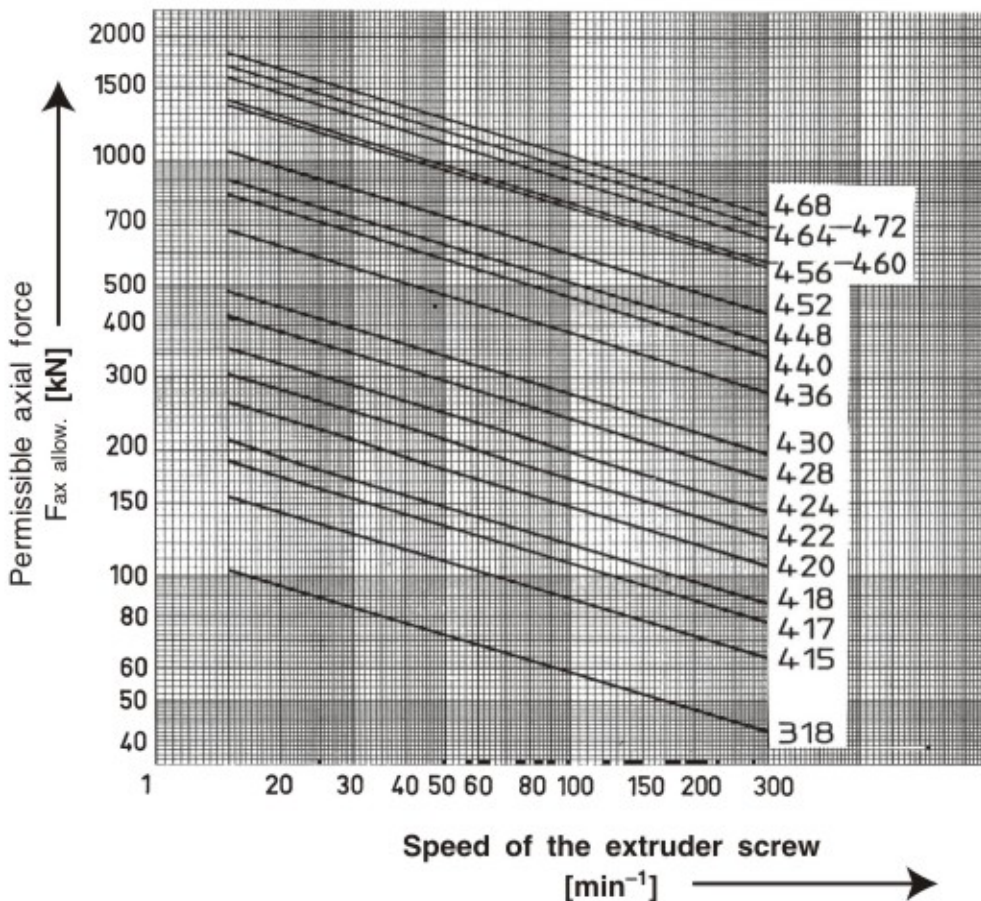

Thrust bearing and Hollow shaft Elecon Standard

Keyway as per per DIN 6885/1

EPEX Type	Axial self aligning roller bearing		Thrust bearing housing										Hollow shaft					
	Dynamic capacity [kN]	Index	D <sub>r</sub> ∅	d <sub>r</sub> ∅ <sub>hr</sub>	L <sub>r</sub>	F	d <sub>i</sub>	d <sub>o</sub>	t <sub>s</sub>	x	No. Of Bolts	d <sub>H</sub> ∅	L <sub>H</sub>	d <sub>i</sub> ∅	d <sub>Hmax</sub> ∅	L <sub>i</sub>	Keys	d <sub>o</sub> ∅
X.14-318	345	29318E	250	160	95	8	210	M16	30	5	8	110	336	50	61	100	1	25
X.14-415	518	29415E	250	160	108	8	210	M16	30	5	8	100	365	45	57	80	2	25
X.14-417	633	29417E	280	180	120	8	230	M20	35	5	8	110	361	50	61	100	1	25
X.14-418	702	29418E	280	190	125	8	240	M20	35	5	8	110	366	50	61	100	1	25
X.14-420	863	29420E	298	210	140	8	260	M20	35	5	8	120	381	50	61	100	1	25
X.16-418	702	29418E	280	190	125	8	240	M20	35	5	8	110	386	50	61	110	2	30
X.16-420	863	29420E	298	210	140	8	260	M20	35	5	8	120	381	60	74	90	2	30
X.16-422	1010	29422E	330	230	145	8	280	M24	40	5	8	130	386	70	84	120	1	30
X.16-424	1170	29424E	355	250	150	10	310	M24	40	5	8	150	391	80	95	100	1	30
X.18-420	863	29420E	298	210	140	8	260	M20	35	5	8	120	469	60	74	130	2	30
X.18-422	1010	29422E	330	230	145	8	280	M24	40	5	8	130	454	70	84	110	2	30
X.18-424	1170	29424E	355	250	150	10	310	M24	40	5	8	150	459	80	96	140	1	30
X.18-428	1400	29428E	378	280	170	10	340	M24	40	5	8	170	479	80	96	140	1	30
X.20-424	1170	29424E	355	250	150	10	310	M24	40	5	8	150	484	80	96	110	2	40
X.20-428	1400	29428E	378	280	170	10	340	M24	40	5	8	170	479	90	106	150	1	40
X.20-430	1610	29430E	410	300	175	10	360	M24	40	5	8	180	484	100	118	120	1	40
X.22-428	1400	29428E	378	280	170	10	340	M24	40	5	8	170	543	90	106	140	2	40
X.22-430	1610	29430E	410	300	175	10	360	M24	40	5	8	180	548	100	118	160	1	40
X.22-436	2250	29436E	468	360	205	10	420	M30	50	5	8	220	578	130	151	140	1	40
X.25-436	2250	29436E	468	360	205	10	420	M30	50	5	8	220	606	130	151	170	1	50
X.25-440	2760	29440E	510	400	225	12	460	M30	50	5	8	240	626	140	165	150	1	50
X.28-436	2250	29436E	468	360	205	10	420	M30	50	5	8	220	670	130	151	150	2	60
X.28-440	2760	29440E	510	400	225	12	460	M30	50	5	8	240	690	140	165	180	1	60
X.28-448	2990	29448E	558	440	230	12	510	M36	60	5	8	290	695	170	197	180	1	60
X.31-440	2760	29440E	510	400	225	12	460	M30	50	5	8	240	692	140	165	160	2	60
X.31-448	2990	29448E	558	440	230	12	510	M36	60	5	8	290	697	170	197	180	1	60
X.31-452	3510	29452E	620	480	245	12	550	M36	60	5	8	310	712	180	210	200	1	60
X.35-440	2760	29440E	510	400	335	23	460	M30	50	10	8	200	840	130	147	195	2	60
X.35-448	2990	29448E	570	440	340	23	510	M36	60	10	12	240	845	170	191	255	1	60
X.35-452	3510	29452E	620	480	360	23	550	M36	60	10	12	260	865	190	213	285	1	60
X.35-456	4310	29456E	680	520	395	27.5	600	M36	60	10	12	280	900	200	223	300	1	70
X.40-448	2990	29448E	570	440	325	23	510	M36	60	10	12	240	835	170	191	255	2	60
X.40-452	3510	29452E	620	480	355	23	550	M36	60	10	12	260	865	190	213	285	2	60
X.40-456	4310	29456E	680	520	385	27.5	600	M36	60	10	12	280	895	200	223	300	1	70
X.40-460	4370	29460E	700	540	410	32.5	620	M36	60	10	12	300	920	220	245	330	1	70
X.42-452	3510	29452E	620	480	355	23	550	M36	60	10	12	260	930	190	213	285	2	60
X.42-456	4310	29456E	680	520	385	27.5	600	M36	60	10	12	280	960	200	223	300	2	70
X.42-460	4370	29460E	700	540	410	32.5	620	M36	60	10	12	300	985	220	245	330	1	70
X.42-464	4950	29464E	800	650	445	33	720	M36	60	10	12	320	1020	240	267	360	1	80
X.45-456	4310	29456E	680	520	385	27.5	600	M36	60	10	12	280	985	200	223	300	2	70
X.45-460	4370	29460E	700	540	410	32.5	620	M36	60	10	12	300	1010	220	245	330	2	70
X.45-464	4950	29464E	800	650	445	33	720	M36	60	10	12	320	1045	240	267	360	1	80
X.45-468	5750	29468E	860	700	500	40	780	M42	70	10	12	340	1100	250	277	375	1	80
X.47-460	4370	29460E	700	540	370	32.5	620	M36	60	10	12	300	975	220	245	330	2	70
X.47-464	4950	29464E	800	650	405	33	720	M36	60	10	12	320	1010	240	267	360	2	80
X.47-468	5750	29468E	860	700	470	40	780	M42	70	10	12	340	1075	250	277	375	1	80
X.47-472	5350	29472E	900	700	490	41.5	800	M42	70	10	12	360	1095	270	297	405	1	90

Thrust bearing and Hollow shaft Elecon Standard

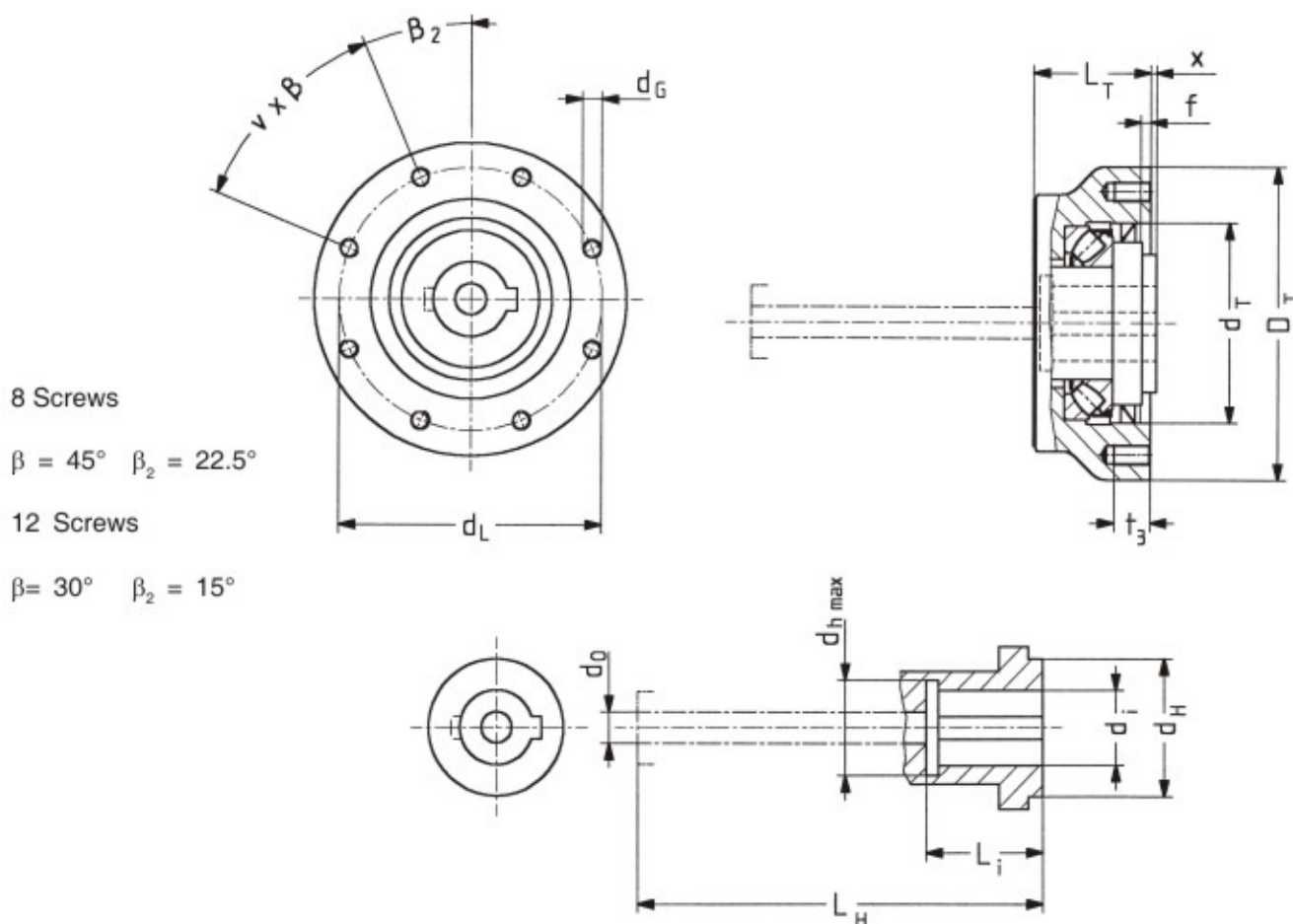

Dimensions

Thrust bearing and Hollow shaft - acc. to client's requirements

Dimensions see overleaf

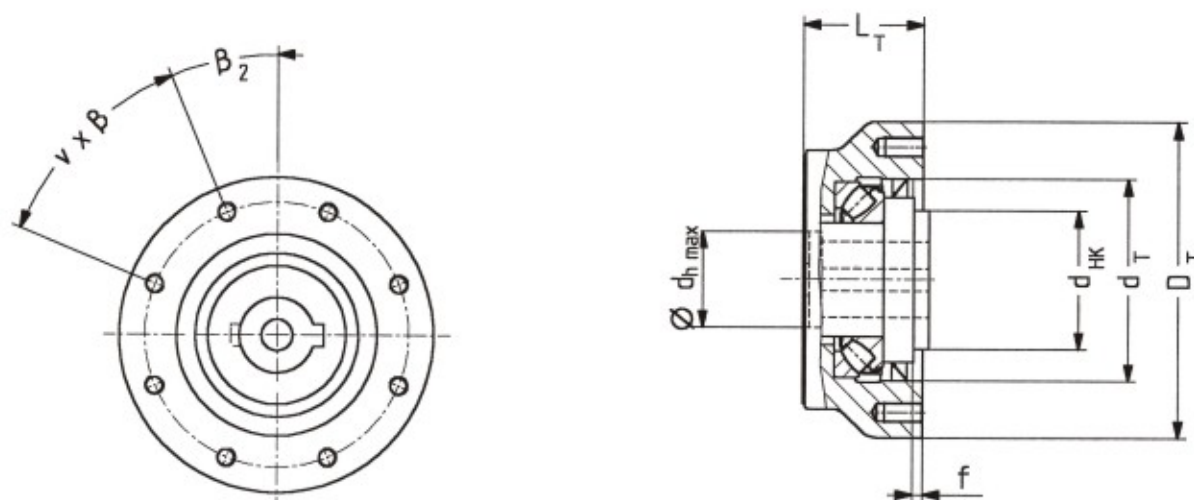

## Thrust bearing and Hollow shaft - acc. to client's requirements

Keyway as per DIN 6885/1

Output hollow shaft with involute splines acc. to DIN 5480 or other profiles acc.to client's requirements

EPEX Type	Axial self aligning roller bearing		Thrust bearing housing					Hollow shaft	
	Dynamic Capacity [kN]	Index	D <sub>T</sub> —	d <sub>T</sub> —H7	L <sub>T</sub>	f	v No. of Bolts	d <sub>H</sub> —	d <sub>H</sub> max —
X.14-318	345	29318E	250	160	95	8	8	110	61
X.14-415	518	29415E	250	160	108	8	8	100	57
X.14-417	633	29417E	280	180	120	8	8	110	61
X.14-418	702	29418E	280	190	125	8	8	110	61
X.14-420	863	29420E	298	210	140	8	8	120	61
X.16-418	702	29418E	280	190	125	8	8	110	61
X.16-420	863	29420E	298	210	140	8	8	120	74
X.16-422	1010	29422E	330	230	145	8	8	130	84
X.16-424	1170	29424E	355	250	150	10	8	150	95
X.18-420	863	29420E	298	210	140	8	8	120	74
X.18-422	1010	29422E	330	230	145	8	8	130	84
X.18-424	1170	29424E	355	250	150	10	8	150	96
X.18-428	1400	29428E	378	280	170	10	8	170	96
X.20-424	1170	29424E	355	250	150	10	8	150	96
X.20-428	1400	29428E	378	280	170	10	8	170	106
X.20-430	1610	29430E	410	300	175	10	8	180	118
X.22-428	1400	29428E	378	280	170	10	8	170	106
X.22-430	1610	29430E	410	300	175	10	8	180	118
X.22-436	2250	29436E	468	360	205	10	8	220	151
X.25-436	2250	29436E	468	360	205	10	8	220	151
X.25-440	2760	29440E	510	400	225	12	8	240	165
X.28-436	2250	29436E	468	360	205	10	8	220	151
X.28-440	2760	29440E	510	400	225	12	8	240	165
X.28-448	2990	29448E	558	440	230	12	8	290	197
X.31-440	2760	29440E	510	400	225	12	8	240	165
X.31-448	2990	29448E	558	440	230	12	8	290	197
X.31-452	3510	29452E	620	480	245	12	8	310	210
X.35-440	2760	29440E	510	400	335	23	8	200	147
X.35-448	2990	29448E	570	440	340	23	12	240	191
X.35-452	3510	29452E	620	480	360	23	12	260	213
X.35-456	4310	29456E	680	520	395	27.5	12	280	223
X.40-448	2990	29448E	570	440	325	23	12	240	191
X.40-452	3510	29452E	620	480	355	23	12	260	213
X.40-456	4310	29456E	680	520	385	27.5	12	280	223
X.40-460	4370	29460E	700	540	410	32.5	12	300	245
X.42-452	3510	29452E	620	480	355	23	12	260	213
X.42-456	4310	29456E	680	520	385	27.5	12	280	223
X.42-460	4370	29460E	700	540	410	32.5	12	300	245
X.42-464	4950	29464E	800	650	445	33	12	320	267
X.45-456	4310	29456E	680	520	385	27.5	12	280	223
X.45-460	4370	29460E	700	540	410	32.5	12	300	245
X.45-464	4950	29464E	800	650	445	33	12	320	267
X.45-468	5750	29468E	860	700	500	40	12	340	277
X.47-460	4370	29460E	700	540	370	32.5	12	300	245
X.47-464	4950	29464E	800	650	405	33	12	320	267
X.47-468	5750	29468E	860	700	470	40	12	340	277
X.47-472	5350	29472E	900	700	490	41.5	12	360	297

## Gear box rating

- I Selection of type and size of the reducer
- I Required ratio  $i_{requ} = \frac{n1}{n2}$
- I Choice of the corresponding nominal ratio  $iN$   
(for the actual ratio  $iN$  see the page 10)
- I Selection of reducer size  
Check of the nominal power rating of the reducer  
 $P_N \quad P_e \cdot f_1$   
 $f_1$  = application factor (between 1.5 and 2.0 in accord.with ELECON)  
Determine the required torque  
 $T_{requ} = 9550 \frac{P_N}{n2} \cdot f_1$
- I Selection of cooling system  
 $P_t \quad P_e$   
 $P_t = P_{t_3} \cdot f_w \cdot f_A \cdot f_L$

$n1$	[min <sup>-1</sup> ]	input speed of the reducer
$n2$	[min <sup>-1</sup> ]	output speed of the reducer
$i_{requ}$		required ratio
$iN$		nominal ratio
$i_{actual}$		actual ratio
$P_M$	[kW]	motor power
$P_N$	[kW]	nominal reducer power
$P_e$	[kW]	effective machine power
$f_1$		application factor
$f_A$		utilisation factor
$f_w$		thermal factor
$f_L$		thrust bearing factor
$T_{requ}$	[Nm]	required reducer output torque
$P_t$	[kW]	thermal limit power of the reducer
$P_{t0}$	[kW]	thermal limit power of the reducer without special cooling measures
$P_{t3}$	[kW]	thermal limit power of the reducer with cooling coil
$\vartheta_u$	[°C]	ambient temperature

### Rating example

**Working machine** : Profile extruding machine

Actual extruder power :  $P_e = 50$  kW

Speed :  $n2 = 100$  min<sup>-1</sup>

Ambient temperature :  $\vartheta_u = 30^\circ$  C

Application factor :  $f_1 = 1.6$

**Driving machine** : three phase A.C. motor (squirrel-cage motor)

Motor power :  $P_M = 55$  kW, motor speed:  $n1 = 1450$  min<sup>-1</sup>

### Selection

1. Demanded : extruder drive for horizontal installation, disposition R11 with hollow shaft (see the ordering example)

2. Ratio :

$$i_{requ} = n1 / n2 = 1450/100 = 14.5$$

$$iN = 14$$

3. Required output torque of the gear box :  $T_{requ} = 9550 \frac{P_e}{n2} \cdot f_1$

$$T_{requ} = 9550 \frac{50}{100} \cdot 1.6 = 7650 \text{ Nm}$$

In the torque table (Page 11) may be found the design XC 18 with 8360 Nm

The actual ratio of this reducer is :  $i_{actual} = 14.2$  (page 10)

4. Thermal limit verification :  $P_e \leq P_t$  in which  $P_t = P_{t_3} \cdot f_A \cdot f_w \cdot f_L$  (thermal limit power and factors see page 13)

$P_{t_3}$  :  $P_{t3}$  thermal limit power with cooling coil

$$P_{t3} = 133 \text{ kW}$$

with the utilisation factor  $f_A$  from the table 2 :

$$f_A = 0.91 \quad \text{for} \quad \frac{P_e}{P_N} = \frac{50}{94} \cdot 100\% = 53\%$$

with the thrust bearing factor  $f_L$  from the table 3 :

$$f_L = 0.89$$

With the temperature factor  $f_w$  from the table 1 :

$$f_w = 0.86 \text{ for } \vartheta_u = 30^\circ \text{ C}$$

Reducer with cooling coil:  $P_t = 133 \cdot 0.91 \cdot 0.86 \cdot 0.89 = 92.6$  kW

$$P_e = 50 \text{ kW} < P_t = 92.6 \text{ kW}$$

**Complete designation** for the reducer and the thrust bearing housing

XC	18	-	R1	1	-	H	11	-	14	-	Z	3	-	424
----	----	---	----	---	---	---	----	---	----	---	---	---	---	-----

Input drive using belt pulleys:

Because of the different loads and because of the dependence of the bearing life duration on the belt radial force working angle, please ask for precisions if this occurs.

If, after the verification of the standard bearing configuration, the bearing life duration results as insufficient, optionally reinforced bearing configuration may be offered.

# Combination

## Combination : Gear Unit – Thrust Bearing Case

Size	318	415	417	418	420	422	424	428	430	436	440	448	452	456	460	464	468	472
XC/XD 14	•	•	•	•	•													
XC/XD 16				•	•	•	•											
XC/XD 18					•	•	•	•										
XC/XD 20							•	•	•									
XC/XD 22								•	•	•								
XC/XD 25										•	•							
XC/XD 28										•	•	•						
XC/XD 31											•	•	•					
XC/XD 35											•	•	•	•				
XC/XD 40												•	•	•	•			
XC/XD 42													•	•	•	•		
XC/XD 45														•	•	•	•	
XC/XD 47															•	•	•	•

### Example

**K XD 22-R1 1-H 11-25-Z 3-420** ——— *Thrust bearing housing*

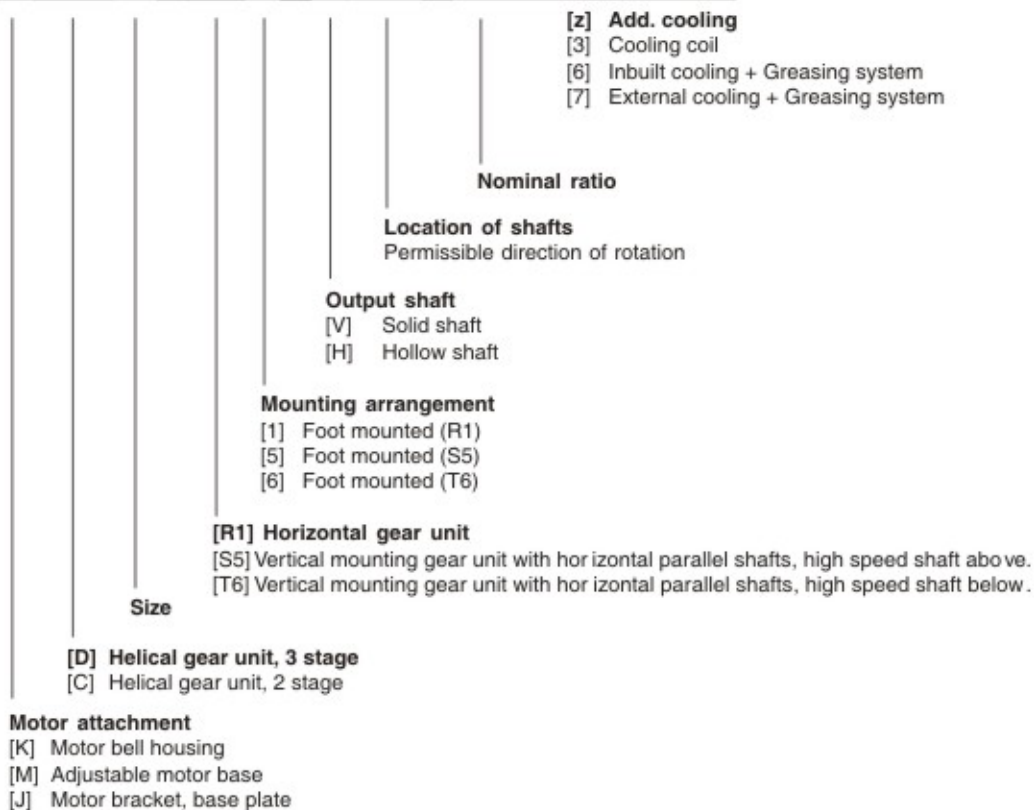

## Exact ratios

### Helical Gear Units, two-stage

Type	Size												
<b>XC</b>	<b>14</b>	<b>16</b>	<b>18</b>	<b>20</b>	<b>22</b>	<b>25</b>	<b>28</b>	<b>31</b>	<b>35</b>	<b>40</b>	<b>42</b>	<b>45</b>	<b>47</b>
<b>iN</b>	<b>Exact ratios</b>												
<b>4</b>	3.98		4.00		3.95		4.03		3.97		3.92		
<b>4.5</b>	4.46		4.49		4.44		4.52		4.48		4.39		
<b>5</b>	5.01		5.06		5.01		5.10		5.06	5.24	4.92	4.83	
<b>5.6</b>	5.64		5.72	5.77	5.66	5.39	5.76	5.45	5.74	5.90	5.54	5.41	
<b>6.3</b>	6.38	6.48	6.35	6.49	6.29	6.06	6.40	6.13	6.27	6.68	6.27	6.08	6.00
<b>7.1</b>	7.24	7.26	7.26	7.31	7.18	6.83	7.31	6.90	7.16	7.58	7.12	6.84	6.72
<b>8</b>	7.89	8.15	7.94	8.26	7.86	7.71	8.00	7.80	7.68	8.27	7.76	7.73	7.54
<b>9</b>	8.89	9.18	9.00	9.18	8.91	8.57	9.07	8.67	8.70	9.45	8.74	8.79	8.49
<b>10</b>	10.1	10.4	9.90	10.5	9.80	9.80	9.98	9.90	9.99	10.1	9.95	9.58	9.60
<b>11.2</b>	11.2	11.8	11.4	11.5	11.3	10.7	11.5	10.8	10.9	11.5	11.0	10.8	10.9
<b>12.5</b>	13.0	12.9	12.7	13.0	12.6	12.1	12.8	12.3	12.8	13.2	12.8	12.3	11.9
<b>14</b>	14.5	14.5	14.2	14.3	14.0	13.4	14.3	13.5	14.4	14.3	14.2	13.5	13.4
<b>16</b>	16.2	16.5	16.1	16.5	15.7	15.4	16.2	15.6	15.9	16.9	15.5	15.7	15.3
<b>18</b>	17.8	18.2	17.8	18.4	17.3	17.1	18.2	17.3	17.8	18.9	17.6	17.6	16.8
<b>20</b>		21.1		20.5		19.1		19.3		21.0		19.1	19.5
<b>22.4</b>		23.5		23.2		21.4		22.0		23.5		21.8	21.8
<b>25</b>		26.3		25.7		23.6		24.7					23.7
<b>28</b>		28.9											27.0

### Helical Gear Units, three-stage

Type	Size												
<b>XD</b>	<b>14</b>	<b>16</b>	<b>18</b>	<b>20</b>	<b>22</b>	<b>25</b>	<b>28</b>	<b>31</b>	<b>35</b>	<b>40</b>	<b>42</b>	<b>45</b>	<b>47</b>
<b>iN</b>	<b>Exact ratios</b>												
<b>16</b>			15.9				16.1		16.1		16.1		
<b>18</b>			17.7				18.0		18.1		17.9		
<b>20</b>	20.8		20.1		19.6		20.4		20.0	21.2	19.5	19.8	
<b>22.4</b>	23.2		22.5	22.9	21.9		23.0	21.8	23.0	23.8	23.0	22.1	
<b>25</b>	25.8		25.1	25.6	24.5	26.7	25.7	24.3	25.9	26.4	25.6	24.1	24.6
<b>28</b>	28.4		28.5	29.0	27.0	29.8	29.2	27.7	28.6	30.3	27.9	28.3	27.4
<b>31.5</b>	32.1	33.8	31.5	32.5	31.4	33.4	32.8	31.2	32.1	34.1	31.7	31.6	29.9
<b>35.5</b>	35.8	37.7	35.1	36.2	35.1	36.8	35.7	34.8	35.9	37.7	35.6	34.4	35.2
<b>40</b>	40.0	42.1	39.8	41.1	39.3	42.9	40.6	39.6	39.7	42.4	38.7	39.2	39.2
<b>45</b>	43.9	46.2	44.0	45.5	43.2	47.8	45.5	44.4	44.6	47.4	44.1	43.9	42.7
<b>50</b>	51.9	52.3	51.7	50.7	49.3	53.6	51.2	48.3	51.1	52.4	51.0	47.8	48.6
<b>56</b>	57.9	58.2	57.7	57.5	55.0	58.9	57.1	54.9	57.4	58.8	56.9	54.4	54.5
<b>63</b>	64.6	65.0	65.5	63.6	61.7	67.3	64.9	61.7	63.6	67.4	62.0	63.0	59.3
<b>71</b>	71.0	71.5	72.4	74.7	67.8	75.0	72.9	69.3	71.3	75.8	70.5	70.2	67.5
<b>80</b>		84.5	79.0	83.3		84.1	80.0	77.3	79.0	83.9	80.9	76.5	78.2
<b>90</b>		94.2	89.6	94.6		92.5	90.9	87.9	87.4	94.1	88.2	87.0	87.1
<b>100</b>		105	99.1	105			102	98.7	98.1	104	100	99.9	94.9
<b>112</b>		116		114				108		115		109	108
<b>125</b>				129				123		129		124	124
<b>140</b>				143				138					135
<b>160</b>													154

iN = Nominal Ratio

## Nominal Output Torques

Type	Size													
XC	14	16	18	20	22	25	28	31	35	40	42	45	47	
iN	Nominal Output Torques T <sub>2N</sub> [kNm]													
4	3.10		5.86		13.8		21.4		45.8		63.7			
4.5			6.59		14.3		24.1		50.1		71.6			
5	3.12		7.32		14.6		24.5		50.9	57.3	79.6	79.6		
5.6	3.26		8.20	8.20	15.3	19.3	25.3	29.9	53.5	62.4	89.1	89.1		
6.3		4.61	8.48	9.23	16.0	20.1	26.5	33.7	57.0	64.2	92.3	100	100	
7.1		5.10	8.85	10.4	16.6	20.8	27.1	34.8		67.8	101	113	113	
8			8.86	11.8	16.8	20.9	29.0	36.2		71.8		117	127	
9						21.4	30.8	37.8	76	105	126	155	143	146
10						22.8	32.2	38.2						
11.2			5.41	11.8	16.8	23.2	32.2	42.0	59.3	76	105	126	155	
12.5						24.2	33.9		60.4					
14			8.36	11.8	16.8	24.6	32.0	43.5	57.0	79	104	131	155	
16		3.10	8.20											44.9
18	3.16				23.3		46.4		76		129	161		
20					21.4		43.7				126	164		
22.4					22.8		42.8					160		
25		5.10										160		
28												155		

## Power ratings

Type	Size															
XC	14	16	18	20	22	25	28	31	35	40	42	45	47			
Helical Gear Units, two-stage	iN	n <sub>1</sub>	n <sub>2</sub>	Nominal Power P <sub>N</sub> [kW]												
		[min <sup>-1</sup> ]														
	4	1500 1000	375 250	121 81		230 153		542 360		840 560		1800 1200		2500 1670		
	4.5	1500 1000	335 220	108 72		230 153		500 360		840 560		1750 1170		2500 1670		
	5	1500 1000	300 200	98 65		230 153		460 350		770 513		1600 1070	1800 1200	2500 1670	2500 1670	
	5.6	1500 1000	270 180	91 58		230 153	230 153	430 310	540 360	710 473	840 560	1500 1000	1750 1170	2500 1670	2500 1670	
	6.3	1500 1000	240 160	81 52	115 85	211 141	230 153	400 270	500 360	661 441	840 560	1430 955	1600 1070	2300 1535	2500 1660	2500 1660
	7.1	1500 1000	211 141	72 46	112 75	196 131	230 153	367 245	460 350	600 400	770 513	1260 840	1500 1000	2230 1490	2500 1670	2500 1670
	8	1500 1000	188 125	64 41	106 71	174 116	232 155	330 220	410 310	570 380	711 474	1120 746	1490 990	1985 1325	2300 1530	2500 1660
	9	1500 1000	167 111	57 36	94 63	155 103	206 137	294 196	374 249	538 358	660 440	995 663	1320 880	1763 1175	2200 1470	2500 1665
	10	1500 1000	150 100	51 33	85 57	139 93	185 123	264 176	358 239	483 322	600 400	895 600	1200 800	1590 1058	1980 1320	2300 1530
	11.2	1500 1000	134 89	46 29	76 51	124 83	165 110	236 157	326 217	452 301	589 391	800 533	1070 710	1420 945	1770 1180	2175 1450
	12.5	1500 1000	120 80	41 26	68 45	111 74	148 99	211 141	304 203	426 284	527 351	745 500	955 640	1320 880	1585 1055	1950 1300
	14	1500 1000	107 71	37 23	61 41	94 63	132 88	189 126	276 184	373 249	470 312	680 452	853 570	1180 786	1415 945	1740 1160
	16	1500 1000	94 63	30 20	53 35	81 54	116 77	160 110	242 161	314 209	427 285	560 370	775 520	1020 680	1290 860	1520 1015
	18	1500 1000	83 56	28 18	47 31	71 48	103 69	145 96	215 143	280 187	392 261	500 330	690 460	878 590	1170 780	1355 900
	20	1500 1000	75 50		42 28		93 62		183 122		364 243		596 398		1010 675	1270 845
	22.4	1500 1000	67 44.5		38 25		82 55		160 105		306 204		533 355		884 587	1150 770
	25	1500 1000	60 40		32 21		74 49		143 95		269 179					1005 670
	28	1500 1000	54 35.5		29 19											875 575

### Nominal Output Torques

Type	Size													
XD	14	16	18	20	22	25	28	31	35	40	42	45	47	
iN	Nominal Output Torques T <sub>2N</sub> [kNm]													
16			8.86				27.6		59.3					
18			8.36				30.8		60.4					
20	3.26		8.20				32.0		57.0	79.0	105	131		
22.4			8.86		16.8		33.9	37.5	59.3			134		
25	3.01		8.36			24.6		42.0	60.4	76.0		131	161	
28	3.16		8.20			23.3		32.0	45.7	57.0	79.0		164	
31.5	3.26	5.41	8.36			16.8	22.8	33.9	47.0	60.4		101	134	161
35.5												76.0	105	129
40	3.10	5.10	8.20			16.5	24.6	32.0	43.7	57.0		101	126	164
45	3.16							23.3		42.8	57.0	79.0	101	134
50	3.26	5.41	8.86			16.8	22.8	33.9	47.0	59.3		105	129	155
56					8.36									126
63	3.10	5.10	8.20			16.5	24.6	32.0	42.8	57.0	79.0		131	160
71	3.16							23.3		47.0	57.0	79.0	101	134
80		5.41	8.36				22.8	30.8		60.4		105	129	161
90									32.0	43.7	57.0		101	126
100		5.10	8.20						42.8		79.0	101	134	160
112												76.0		129
125									43.7				126	164
140									42.8					160
160														155

### Power ratings

Type	Size															
XD	14	16	18	20	22	25	28	31	35	40	42	45	47			
iN	Nominal Power P <sub>N</sub> [kW]															
16	1500 1000	n1 94 63							300 200		582 388		1031 687			
18	1500 1000	83 56							267 178		527 351		917 611			
20	1500 1000	75 50	26 17						252 168		447 298	621 414	817 545	1029 686		
22.4	1500 1000	67 44.5	23 15.2						238 159	294 195	416 277	554 369	737 491	937 625		
25	1500 1000	60 40	19.5 13						155 103	213 142	264 176	380 253	477 318	660 440	808 539	1013 675
28	1500 1000	54 35.5	18 12						130 87	180 120	256 171	322 209	443 295	584 389	735 490	922 615
31.5	1500 1000	47.5 31.5	16 11	27 18					113 75	160 107	235 157	284 189	394 263	502 333	666 444	796 531
35.5	1500 1000	42.5 28	14 9.3	24 16					101 67	150 100	208 139	267 178	338 223	465 310	569 379	713 475
40	1500 1000	37.5 25	12.2 8.1	20 13.3					97 65	126 84	172 115	224 149	300 200	409 273	495 330	645 430
45	1500 1000	33.5 22.2	11 7.3	18 12					81 54	112 75	150 100	200 133	276 184	354 235	466 311	557 371
50	1500 1000	30 20	10 6.7	17 11					71 47	106 71	148 99	186 124	234 156	330 220	404 269	487 324
56	1500 1000	27 17.9	9.1 6.1	15 10					64 43	95 63	123 82	169 113	215 142	295 197	356 236	461 307
63	1500 1000	23.8 16	7.7 5.2	12.7 8.5					61 41	80 53	107 71	142 95	197 131	259 173	327 218	398 265
71	1500 1000	21 14	7.0 4.7	11 7.3					51 34	71 47	104 69	126 84	175 117	222 148	295 197	340 227
80	1500 1000	18.8 12.5		11 7.3					45 30	60 40	92 61	119 79	149 99	206 137	252 168	317 211
90	1500 1000	16.7 11.1		9.4 6.3					40 27	56 37	76 51	99 66	133 89	182 121	220 146	284 191
100	1500 1000	15 10		7.7 5.1						50 33	67 45	90 60	124 83	158 105	210 140	251 167
112	1500 1000	13.4 8.9		7.2 4.8							59 39		106 71		180 120	217 144
125	1500 1000	12 8									55 37		96 64		158 105	206 137
140	1500 1000	10.7 7.1									48 32					179 119
160	1500 1000	9.4 6.3														152 102

## Thermal capacities

Average air speed	Type XC...R1													
	Size													
	14	16	18	20	22	25	28	31	35	40	42	45	47	
<b>P<sub>10</sub> [kw] without add. cooling</b>														
Vw=0.5 m/s 1)	30	40	50	64	78	94	111	132	149	191	216	260	315	
Vw=1.2 m/s 2)	42	55	70	89	108	130	154	184	207	265	300	361	437	
Vw=4.0 m/s 3)	54	71	90	114	138	166	197	236	265	339	384	462	559	
<b>P<sub>13</sub> [kw] with cooling coil</b>														
Vw = 0.5 m/s 1)	85	163	113	232	201	414	347	576	469	876	728	945	1000	
Vw = 1.2 m/s 2)	97	178	133	257	231	450	390	628	527	950	812	1046	1122	
Vw = 4.0 m/s 3)	109	193	153	282	261	486	433	680	585	1024	896	1147	1244	
Vw = 0.5 m/s	Values of P <sub>10</sub> and P <sub>13</sub> meant for gearbox sizes 22-47 are applicable from ratios as indicated.						8	8	8	8	12.5	12.5	12.5	12.5
Vw = 1.2 m/s							(For smaller ratios consult ELECON)			7.1	7.1	9	9	9
Vw = 4.0 m/s										5	5	6.3	6.3	6.3
<b>Type XD...R1</b>														
<b>P<sub>10</sub> [kw] without add. cooling</b>														
Vw = 0.5 m/s 1)	20	27	34	42	52	62	73	89	111	127	144	174	210	
Vw = 1.2 m/s 2)	28	37	47	59	72	86	102	123	154	177	200	241	291	
Vw = 4.0 m/s 3)	36	47	60	76	92	110	131	157	197	227	256	308	372	
<b>P<sub>13</sub> [kw] with cooling coil</b>														
Vw = 0.5 m/s 1)	57	109	76	154	134	276	231	385	325	584	485	631	667	
Vw = 1.2 m/s 2)	65	119	89	171	154	300	260	419	368	634	541	698	748	
Vw = 4.0 m/s 3)	73	129	102	188	174	324	289	453	411	684	597	765	829	
Vw = 0.5 m/s	Values of P <sub>10</sub> and P <sub>13</sub> meant for gearbox sizes 35-47 are applicable from ratios as indicated.									20	20	22.4	22.4	22.4
Vw = 1.2 m/s										16	20	16	20	25
Vw = 4.0 m/s										16	20	16	20	25

- 1) Small closed room, little air movement
- 2) Large hall with free air movement
- 3) Constantly strong air movement

θ <sub>u</sub> [°C]	ED 100%	ED 80%
10	1.14	1.21
20	1.00	1.06
30	0.86	0.91
40	0.71	0.76
50	0.57	0.61

Thermal capacities of types XC / XD-S5 and - T6 on request

Utilization P <sub>e</sub> / P <sub>N</sub> [%]								
20	30	40	50	60	70	80	90	100
0.7	0.8	0.86	0.9	0.93	0.96	0.98	0.99	1

Size	Thrust Bearing Case																			
	318	415	417	418	420	422	424	428	430	436	440	448	452	456	460	464	468	472		
XC/XD 14	1.06	1.05	1.05	1.03	1.02															
XC/XD 16				1.02	1.01	1.00	0.97													
XC/XD 18					1.01	1.00	0.98	0.94												
XC/XD 20							0.98	0.96	0.93											
XC/XD 22								0.96	0.94	0.86										
XC/XD 25										0.88	0.81									
XC/XD 28										0.90	0.84	0.79								
XC/XD 31											0.87	0.82	0.76							
XC/XD 35											0.94	0.90	0.85	0.78						
XC/XD 40												0.92	0.88	0.82	0.82					
XC/XD 42													0.90	0.84	0.84	0.81				
XC/XD 45														0.87	0.87	0.84	0.80			
XC/XD 47															0.88	0.85	0.82	0.85		
<b>f<sub>t</sub> for P<sub>13</sub> (with cooling coil)</b>																				
XC/XD 14	1.00	0.98	0.97	0.96	0.93															
XC/XD 16				0.98	0.96	0.94	0.92													
XC/XD 18					0.95	0.92	0.89	0.84												
XC/XD 20							0.94	0.92	0.89											
XC/XD 22								0.92	0.90	0.81										
XC/XD 25										0.89	0.84									
XC/XD 28											0.87	0.81	0.76							
XC/XD 31												0.88	0.85	0.81						
XC/XD 35													0.88	0.85	0.80	0.72				
XC/XD 40														0.91	0.89	0.84	0.83			
XC/XD 42															0.87	0.82	0.81	0.77		
XC/XD 45																0.86	0.85	0.82	0.77	
XC/XD 47																	0.85	0.83	0.78	0.80

Type **XC 14-R1 ... XC 31-R1** (two-stage)  
**XD 14-R1 ... XD 31-R1** (three-stage)

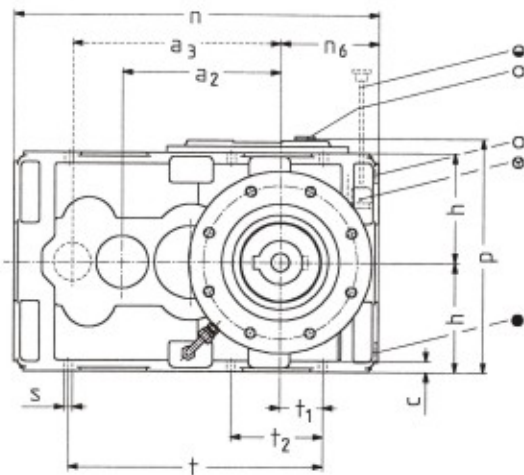

Location of input and output shaft - Directions of rotation

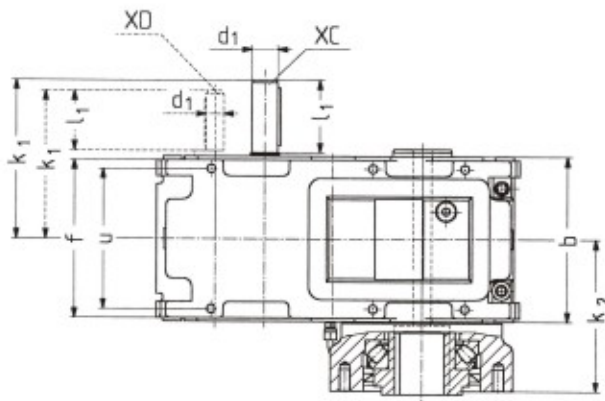
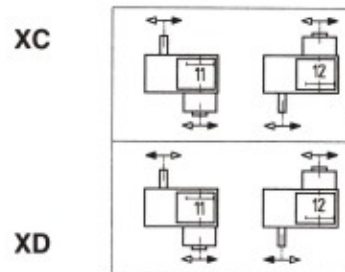

Location of shafts on the same side on request

- Filling Plug
- Oil Level
- Oil Drain
- ⊕ Breather

Type	Input shaft				Oil filling *)[l]	Type	Input shaft				Oil filling *)[l]	
	a <sub>2</sub>	ød <sub>1</sub>	k <sub>1</sub>	l <sub>1</sub>			a <sub>3</sub>	in	ød <sub>1</sub> k <sub>6</sub>	k <sub>1</sub>		l <sub>1</sub>
XC 14	216	35k6	218	100	8	XD 14	285	20...71				8
XC 16	272	35k6	218	100	11	XD 16	341	31.5...112	25	203	82	11
XC 18	293	45k6	275	120	17	XD 18	387	16...45 50...100	35 30	283	100	17
XC 20	347	45k6	275	120	23	XD 20	441	22.4...63 71...140	35 30	283	100	23
XC 22	376	60m6	337	140	31	XD 22	492	20...45 50...71	50 40	347	120	31
XC 25	434	60m6	337	140	40	XD 25	550	25...56 63...90	50 40	347	120	40
XC 28	464	70m6	369	140	51	XD 28	591	16...45 50...100	50 40	362	120	51
XC 31	532	70m6	369	140	70	XD 31	659	22.4...63 71...140	50 40	362	120	70

Tapped centre holes in shaft ends DIN 332 Form DS				
d <sub>1</sub>				
25...30	35	40...50	65...85	>85
M10	M12	M16	M 20	M24

Keys to DIN 6885/1 supplied by ELECON

Type of protection as per IP 55

\*) Standard value only, oil filling acc. to dip stick or oil level glass

Type	b	c	f	h -0.2	n	n <sub>6</sub>	p	ø s	t	t <sub>1</sub>	t <sub>2</sub>	u	Thrust bearing											Weight kg 1)			
													318	415	417	418	420	422	424	428	430	436	440		448	452	
XC/XD 14	226	15	216	150	500	134	333	12	348	58	125	192	208	221	233	238	253									150	
XC/XD 16	226	15	216	180	605	183	393	12	453	107	217	192				238	253	258	263								215
XC/XD 18	294	18	284	190	654	171	419	14.5	486	87	175	248					287	292	297	317							300
XC/XD 20	294	18	284	225	764	227	489	14.5	596	143	285	248						297	317	322							400
XC/XD 22	358	24	346	235	826	215	513	18.5	622	113	226	306							349	354	384						530
XC/XD 25	358	24	346	265	940	271	573	18.5	736	169	340	306									384	404					730
XC/XD 28	420	28	408	280	1000	256	610	24	752	132	265	360										415	435	440			920
XC/XD 31	420	28	408	315	1137	325	680	24	889	201	402	360												435	440	455	1260

1) Combination with bearing of medium size

Type **XC 35-R1 ... XC 47-R1** (two-stage)

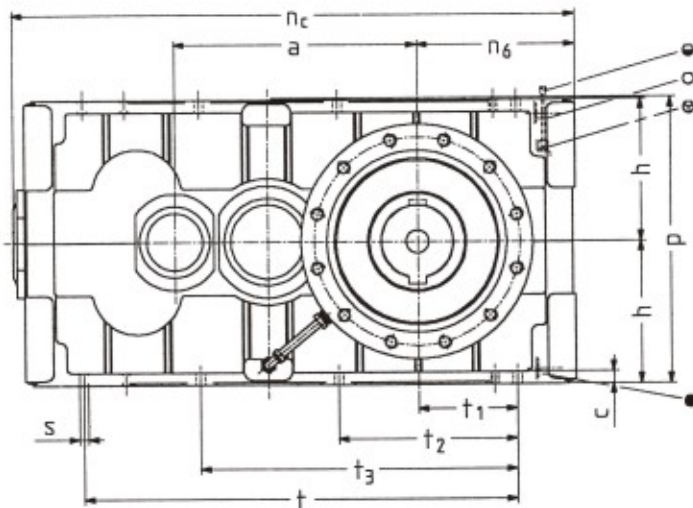

Location of input and output shaft - Directions of rotation

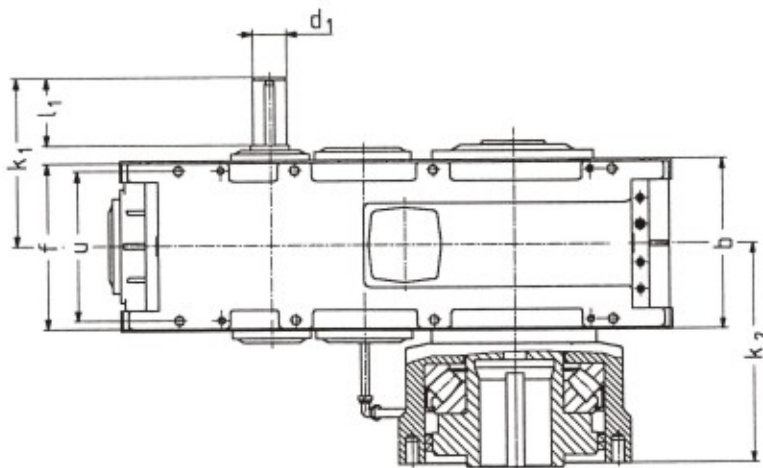
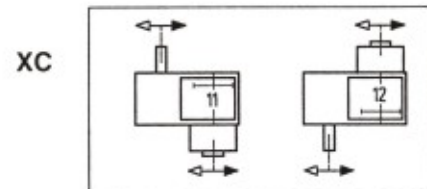

Location of shafts on the same side on request

- Filling Plug
- Oil Level
- Oil Drain
- ⊕ Breather

Tapped centre hole in shaft ends DIN 332 Form DS	
d1	≥ 90
	M24

Type	Input shaft				Oil filling
	a	ød1	k1	l1	*) [l]
XC 35	570	90 <sub>m6</sub>	446	180	60
XC 40	647	90 <sub>m6</sub>	446	180	81
XC 42	693	100 <sub>m6</sub>	537	215	98
XC 45	759	100 <sub>m6</sub>	537	215	140
XC 47	845	100 <sub>m6</sub>	537	215	187

Keys to DIN 6885/1 supplied by **ELECON**. Type of protection as per IP 55

\*) Standard value only, oil filling acc. to dip stick or oil level glass

Type	b	c	f	h -0.2	nc	n6	p	ø s	t	t1	t2	t3	u	Thrust bearing							Weight kg 1)	
														440	448	452	456	460	464	468		472
														k2								
XC 35	450	32	438	300	1346	345	610	24	1005	190	325	695	396	560	565	585	620					2150
XC 40	450	32	438	375	1501	423	760	24	1157	265	477	847	396		550	580	610	635				2605
XC 42	530	40	514	355	1652	422	720	28	1230	225	390	820	460			620	650	675	710			3185
XC 45	530	40	514	425	1786	490	860	28	1356	285	516	946	460			650	675	710	765			4095
XC 47	530	40	514	500	1957	575	1010	28	1527	370	687	1117	460				635	670	735	755		4860

1) Combination with bearing of medium size

Type XC 35-R1 ... XC 47-R1 (Three-stage)

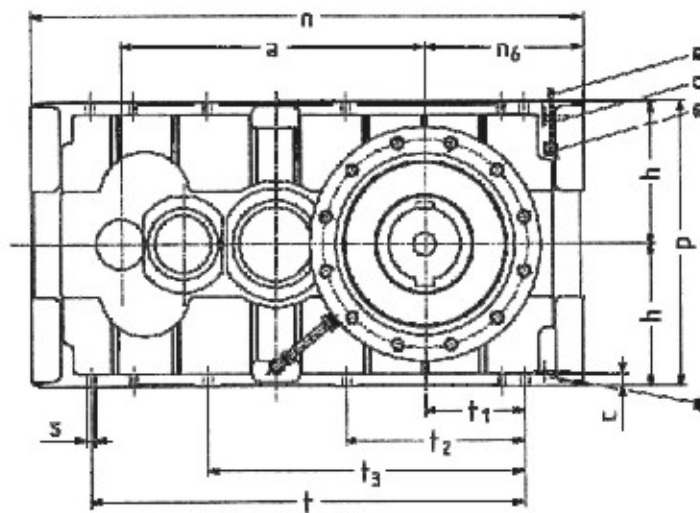

Location of input and output shaft - Directions of rotation

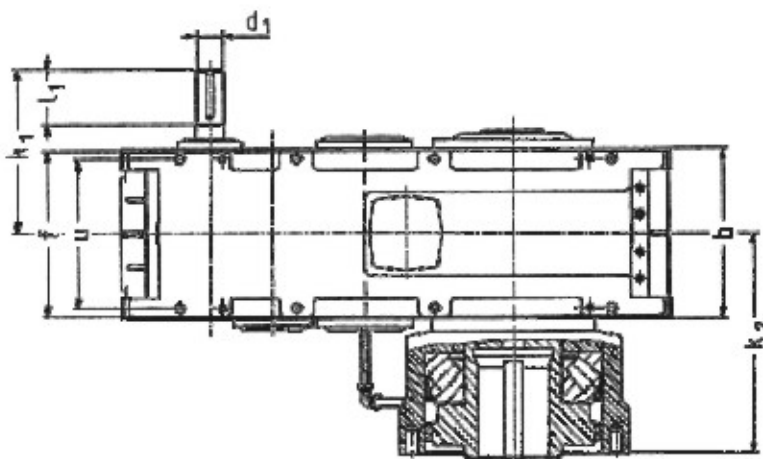
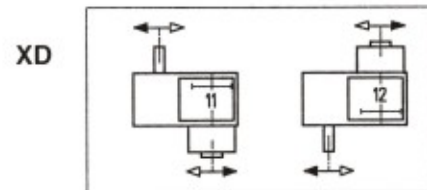

Location of shafts on the same side on request

- Filling Plug
- Oil Level
- Oil Drain
- ⊕ Breather

Keys to DIN 6885/1 supplied by ELECON. Type of protection as per IP 55

\*) Standard Value only, oil filling acc. to dip stick or oil level glass

Type	a	Input shaft					Oil filling *)[l]			
		iN	ød1 m6	k1	l1	iN				
XD 35	734	16...45	70	435	145	50...100	50 <sub>k6</sub>	415	125	65
XD 40	811	20...56	70	435	145	63...125	50 <sub>k6</sub>	415	125	86
XD 42	894	16...45	80	508	170	50...100	65	483	145	108
XD 45	960	20...56	80	508	170	63...125	65	483	145	150
XD 47	1046	25...71	80	508	170	80...160	65	483	145	202

Tapped centre holes in shaft ends DIN 332 Form DS	
d1	
50	60...80
M16	M 20

Type	b	c	f	h -0.2	n	n6	p	ø s	t	t1	t2	t3	u	Thrust bearing						Weight kg 1)						
														440	448	452	456	460	464		468	472				
XD 35	450	32	438	300	1315	345	610	24	1005	190	325	695	396	560	565	585	620					2200				
XD 40	450	32	438	375	1470	423	760	24	1157	265	477	847	396		550	580	610	635					2655			
XD 42	530	40	514	355	1615	422	720	28	1230	225	390	820	460			620	650	675	710					3255		
XD 45	530	40	514	425	1749	490	860	28	1356	285	516	946	460				650	675	710	765					4165	
XD 47	530	40	514	500	1920	575	1010	28	1527	370	687	1117	460					635	670	735	755					4920

1) Combination with bearing of medium size





Cooling coil for horizontal position of gear case R1

XC / XD 14

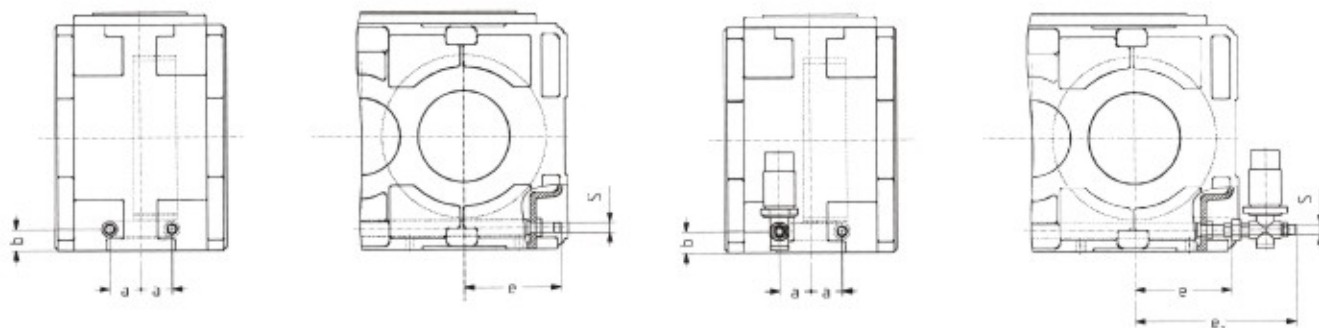

Water connection for cooling coil without cooling water controller

Water connection for cooling coil with cooling water controller

FROM  
XC / XD 16

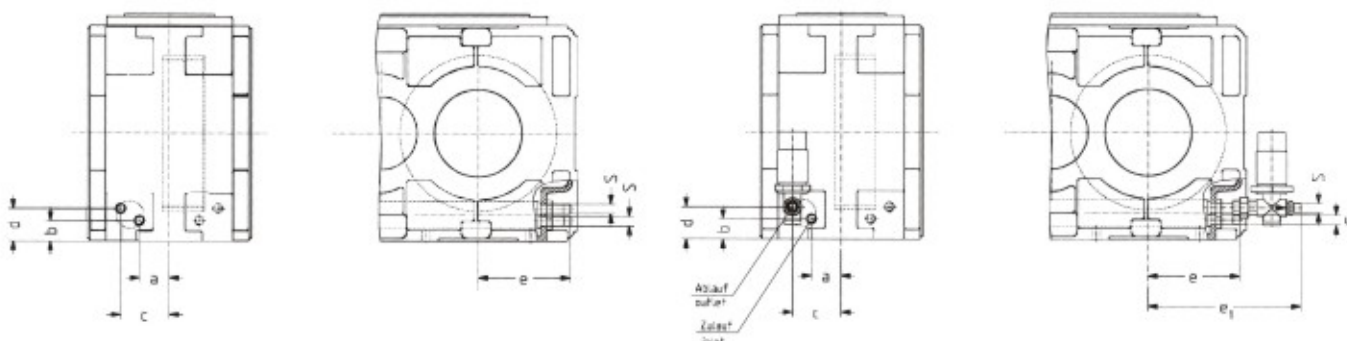

Water connection for cooling coil without cooling water controller

Water connection for cooling coil with cooling water controller

Cooling coil placed adjacent to the final gear wheel. For the gear wheel position see the dimension sheets

Size	a	b	c	d	e	e1	s	water l/min	$\Delta p_w$ bar
14	36	34	-	-	131	294	R 3/8A	6	0.3
16	38	34	38	74	192	346	R 3/8A		0.55
18	44	42	77	65	170	323	R 3/8A		0.3
20	44	42	74	69	225	378	R 3/8A		0.75
22	53	48	88	67	200	353	R 3/8A	12	0.75
25	55	48	76	115	263	399	R 1/2A		0.75
28	55	63	114	101	240	376	R 1/2A		0.55
31	58	60	111	106	300	436	R 1/2A		1.1
35	45	87	115	87	300	436	R 1/2A		0.75
40	35	97	125	97	375	511	R 1/2A		0.5
42	40	100	130	100	336	472	R 1/2A		0.4
45	40	100	130	100	404	540	R 1/2A		0.5
47	40	105	130	105	484	620	R 1/2A	0.5	

# Check-list for ELECON Single shaft Extruder Gearboxes, Series Epex

Client \_\_\_\_\_

## Data specifications of the extruder

Type of machine \_\_\_\_\_

Nominal power \_\_\_\_\_

Nominal output torque \_\_\_\_\_ Maximal output torque \_\_\_\_\_

Nominal speed \_\_\_\_\_

Thrust pressure of the extruder screw \_\_\_\_\_ Extruder screw diameter \_\_\_\_\_

Processing pressure \_\_\_\_\_

Pull-back force of the extruder screw \_\_\_\_\_

Effective duration of the pull back force \_\_\_\_\_

Radial force on the output shaft \_\_\_\_\_

Junction extruder screw - hollow shaft \_\_\_\_\_

- Eccentricity and run-out deviation of the hollow shaft \_\_\_\_\_

- End play of the output hollow shaft \_\_\_\_\_

Fitting dimensions of the screw guide tube \_\_\_\_\_

- Eccentricity and run out deviation on the thrust bearing housing \_\_\_\_\_

## Client's rating specification

Application service factor \_\_\_\_\_

Gear rating acc. to DIN 3990 \_\_\_\_\_

Tooth flank security SH resp. SH<sup>2</sup> \_\_\_\_\_

Root security of the gear tooth SF \_\_\_\_\_

Life duration of the radial bearings \_\_\_\_\_

Life duration of the thrust bearing \_\_\_\_\_ Type of the thrust bearing \_\_\_\_\_

## Technical specification of the gearbox

Type of the driving motor \_\_\_\_\_

Nominal motor power \_\_\_\_\_ Nominal torque of the motor \_\_\_\_\_

Nominal speed of the motor \_\_\_\_\_ Gearbox ratio \_\_\_\_\_

Disposition of the thrust bearing \_\_\_\_\_

Type of the gearbox : - horizontal ● -upright input above ● - upright input below ●

Shaft disposition: "Z" (input opposed to output) ● "U" (input and output on the same side) ●

Drive details: flange mounted motor \_\_\_\_\_ Coupling (type) \_\_\_\_\_

Belt transmission: (iR, d02) \_\_\_\_\_

Lubrication mode \_\_\_\_\_

Cooling measures: - cooling coil ● - separate cooling and press. lubrication device ●

- mounted on cooling and lubrication device ●

Maximal oil temperature \_\_\_\_\_ Temperature of the cooling water \_\_\_\_\_

## Operating and ambient conditions

Operating time \_\_\_\_\_ Ambient temperature \_\_\_\_\_

Special ambient conditions \_\_\_\_\_

Sound pressure level \_\_\_\_\_

## Client's requirements

Acceptance terms and specification \_\_\_\_\_

Test certificates \_\_\_\_\_

Proof of calculation \_\_\_\_\_

Documentation (languages) \_\_\_\_\_

## Commercial specifications

Order quantity \_\_\_\_\_ Annual requirement \_\_\_\_\_

Outline agreement - lot size on call \_\_\_\_\_

Delivery time (first order and former orders) \_\_\_\_\_

Idea of the price \_\_\_\_\_