

ELECON **ELIGN MULTI CROWNED** GEAR COUPLING

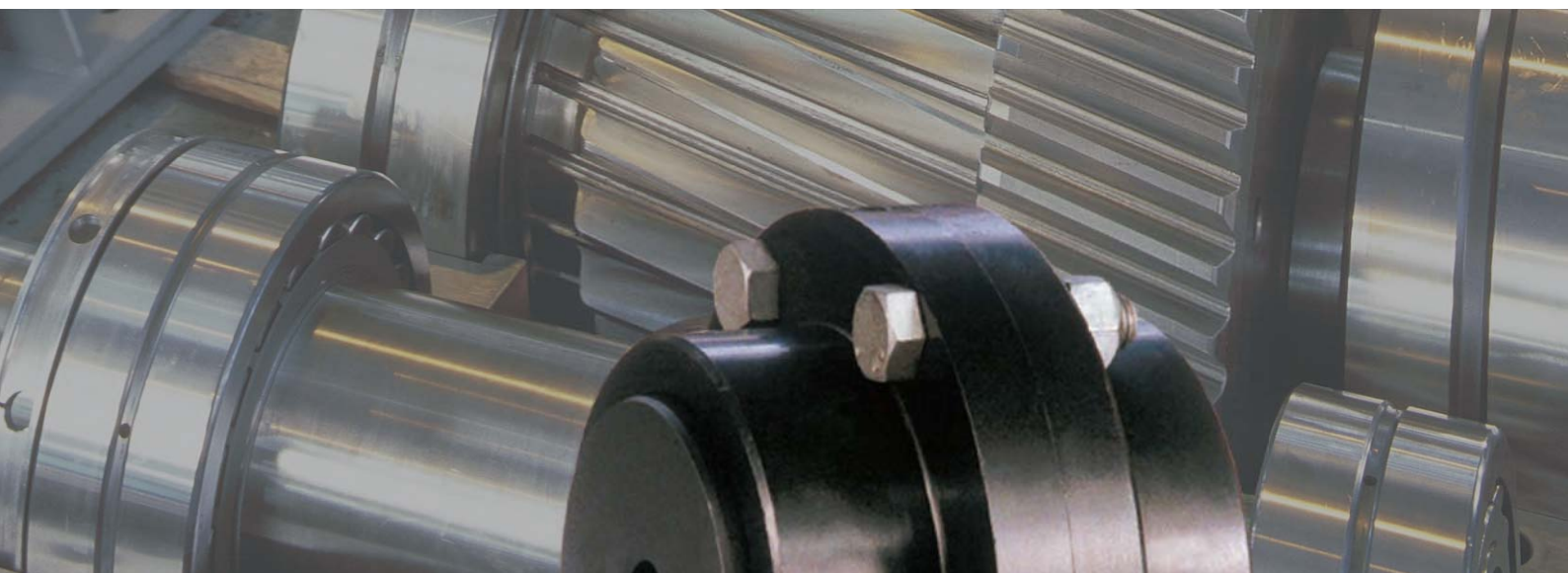

Catalogue No.: 182/G/11/07 R2



www.elecon.com

GEAR COUPLING

Ever Since its inception in 1951 Elecon's endeavour is to constantly update the products and offer superior products to its customers based on the latest technology available. Such a long experience in the field of development, design and manufacture of Power Transmission Equipment has led to the development of a new series of **ELIGN Gear couplings**.

The **ELIGN Gear couplings** are manufactured in Elecon's state of the art technology manufacturing plant on precision CNC machines. The new series of Gear couplings has a technology superiority compared with the other gear coupling available in the market. The usage of high quality material and workmanship is built-in-feature of **ELIGN Gear couplings**.

WHY GEAR COUPLING ?

A Gear Coupling is used to join two rotating shafts for efficient transmission of mechanical power. Although the shafts are accurately aligned at the time of installation, it is likely that during the operation the alignment may get disturbed due to settling of foundation, thermal expansion, shaft deflection, wearing out of other parts, improper maintenance and many more reasons. Due to this unavoidable misalignment occurring during the operation a gear coupling provides a better solution to compensate or minimise the effect of misalignment.

The gear Couplings are therefore ideally suited for wide range of application in the entire field of drive technology.

MISALIGNMENT

The main function of any Gear coupling is not only to connect two rotating shafts but also to accommodate mis-alignments of the connecting shafts **ELIGN Gear coupling** accommodates the following three types of misalignment.

A. Radial

When axes of connected shafts are parallel but not in the same straight line

B. Angular

When axes of connected shafts intersect at center point of coupling but not in the same straight line.

C. Combined radial and angular.

When the axes of connected shafts do not intersect at point of coupling and are not parallel.

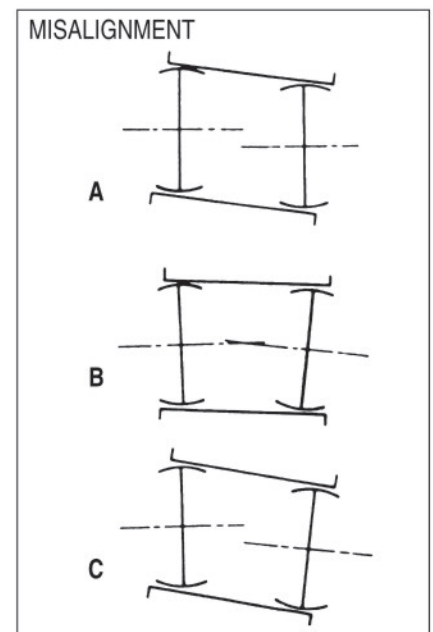
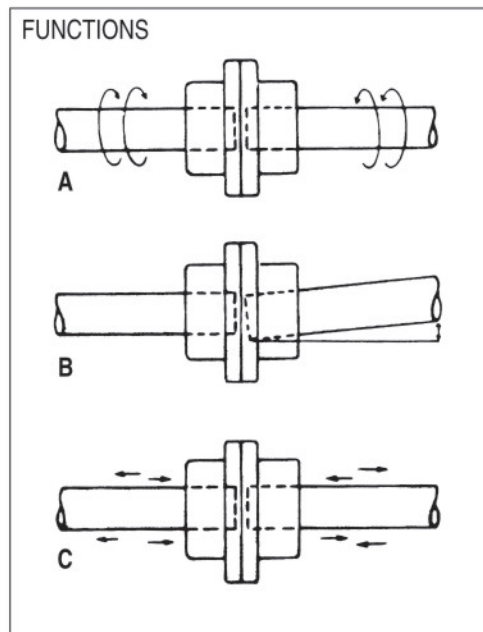

Besides above three types of misalignment, the **ELIGN Gear coupling** also permits axial movement of the shaft..

CAUTION.

Normally permissible angular mis-alignment of **ELIGN gear coupling** is $\pm 0.75^\circ$ for each half. However, it does not mean that the misalignment should be permitted to this limit from the initial installation. Since in case of misalignment occurring during operation the Elign gear coupling takes care of it without undue damage to the connected equipment, however the coupling's life may reduce due to relative motion between hub teeth and housing teeth causing fast wearing out of teeth.

It is therefore extremely important to align the interconnecting shafts precisely during initial installation.

FEATURES OF ELIGN COUPLINGS

ELIGN Gear coupling consists of hubs with multi crowned teeth at Flank, tip and chamfering on teeth.

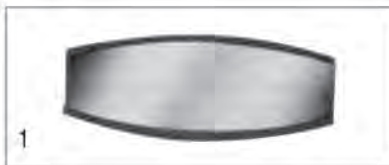
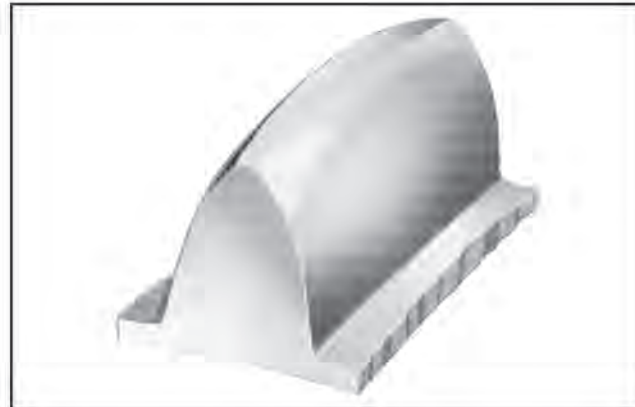

Crowned Flanks : Flanks of the teeth are crowned so that tooth thickness is greatest at that center of the tooth. This assures larger contact area per tooth for higher torque requirements and puts more teeth in contact for a given angle. Actual tooth loading takes place near the center of the tooth face where tooth thickness is greatest, Crowned flanks also eliminate end-of-tooth loading, provide optimum load distribution, and accommodate all types of misalignment with minimum backlash.

Crowned Tips : Tips of teeth are crowned. The crowned tip contacts the root of internal gear teeth in the external sleeve, accurately piloting the sleeve with true concentric ball-and-socket action. This allows minimum diametral sleeve clearance and centers the sleeve physically to assure good dynamic balance characteristics under various loading and misalignment conditions.

Crowned Chamfers : Faces of the teeth adjacent to the tips are chamfered to eliminate interference with the sleeve tooth fillets. This allows the true involute flanks of the gear teeth to be in contact with the sleeve teeth and assures freedom to misalign.

The hub teeth are manufactured on CNC machine. The hub is the heart of any gear coupling and a superior design and tooth profile of the hub enables the gear coupling to operate satisfactorily under all operating conditions with increased reliability and long life.

The multi crowned teeth also reduce the alignment adjustment and improve the load carrying capacity of the teeth. the backlash between the teeth is minimal due to multi-crown tooth design. This is where **ELIGN gear coupling** scores over other gear coupling available in the market.

ELIGN gear coupling is a simple, compact and light unit for transmitting the same power when compared to the couplings of similar capacity available in the market. It is manufactured out of tested quality forged carbon steel and passes through a number of quality checks.

Each half of the **ELIGN gear coupling** is interchangeable with any of other half, of same size of coupling

ORDERING INFORMATION
WHEN ORDERING, SPECIFY FOLLOWING INFORMATION

- 1 Quantity and delivery requirements
- 2 Shaft or bore sizes and keyway dimensions. Give exact dimensions with tolerances.
- 3 **Load** — Horsepower and/or torque at a specific RPM. State normal and maximum conditions.
- 4 **Speed** — minimum, normal and maximum.
- 5 **Application** — type of driver and driven equipment.
- 6 Coupling Series, Type and Size.
- 7 **Space limitations** — envelope dimensions, shaft extensions and shaft spacing.
- 8 Unusual misalignment conditions.
- 9 **Modifications** — tapered bores, special keys, hub cut off, counterbores or others
- 10 Unusual operating conditions ambient temperatures and atmospheres.

SELECTION

- 1 **Obtain Shaft Sizes** Compare shaft sizes of driving and driven equipment with listed maximum bores of desired Series or Type coupling to determine "tentative" Coupling size
- 2 **Compute effective kW/rpm or torque to be transmitted** select a service factor from adjacent table Determine

$$\text{kW/rpm (effective)} = \frac{\text{kW TRANSMITTED X SERVICE FACTOR}}{\text{rpm}}$$

or determine Torque daNm as

$$\text{Torque (effective) daNm} = \frac{955 \text{ X kW TRANSMITTED X SERVICE FACTOR}}{\text{rpm}}$$

Confirm "Tentative" Coupling size or increase to a size which has a kW/rpm torque rating equal to or greater than value computed above.

- 3 **Check Maximum Speed of Application** Refer to maximum speed ratings. These speeds are given only as a guide since the maximum speed depends on the system characteristics.
- 4 **Check Space Limitations** Dimensions of the selected coupling should be compared with space provided in the application to assure proper clearances. Shaft extensions, separation, and clearances to align coupling should be checked.

5 Service Factor

Factor of driven machine											
driven machines	Daily duty (h)			driven machines	Daily duty (h)			driven machines	Daily duty (h)		
	8	16	24		8	16	24		8	16	24
lifts				wood working machinery				Pump			
freight elevators normal duty	1.25	1.35	1.5	decorating drums	1.25	1.35	1.35	rotary pumping plants	1.35	1.5	1.6
freight elevators heavy duty	1.35	1.5	1.7	frames	1.1	1.1	1.25	shaking machines	1.35	1.5	1.6
elevators	1.35	1.5		iron and steel industry				swing sieves	1.1	1.25	1.35
excavators and stackers				blast furnace blowers	1.35	1.35	1.35	textile industry			
bucket excavators (fixed chain)	1.4	1.5	1.7	inclined skip hoists for blast furnaces	1.5	1.5	1.6	bobbin winding machine	1.1	1.25	1.35
bucket chain excavators (loose chain)	1.25	1.35	1.5	cranes				printing and dyeing machines	1.1	1.25	1.35
travels (track)	1.4	1.4	1.4	travels	1.1	1.25	1.35	tan liquor vessels	1.1	1.25	1.35
travels (rail)	1.4	1.4	1.4	hoists	1.25	1.35	1.5	calenders	1.1	1.25	1.35
bucket wheel stackers				slews	1.25	1.3	1.4	willowing machines	1.1	1.25	1.35
bucket wheels	1.4	1.5	1.6	winches	1.25	1.3	1.4	looms	1.1	1.25	1.35
(Clearing/lime/coal)				metal working				compressors, vents			
slew drives	1.25	1.3	1.4	bending machines			1.35	rotary piston compress (U1:100-200)	1.35	1.5	1.6
winches	1.25	1.3	1.4	sheet straightening machine			1.4	rotary piston compressors (U<100)	1.4	1.6	1.6
mining, rock, earth industry				crank presses			1.5	vent N/n .005	1	1	1.1
jaw crushers			1.6	shears			1.35	vent N/n >0.05-0.1	1	1.1	1.25
pit fans			1.4	forging presses			1.5	ventN/n.0.1	1.1	1.15	1.35
cone crushers			1.6	punches			1.5	rolling mills			
chain tramways			1.4	mixers				working roller tables			
rotary crushers			1.6	mixers, liquids	1	1	1.1	strip reels			1.6
jolting machines			1.5	mixture semiliquid	1.1	1.25	1.35	sheet shears			1.6
scale breakers			1.6	mixture granular material	1.1	1.25	1.35	sheet manipulators			1.35
wagon pushers			1.4	concrete mixers	1.1	1.25	1.35	bloom conveying plants	1.6	1.9	1.9
crushing rolls			1.5	mills				wire reels			1.35
chemical industry				hammer mills			2	capstan handles			1.5
agitators, constant density	1	1	1.1	ball mills			1.9	revolving turrets, cont. casting			1.25
agitators, viscous liquids	1.1	1.25	1.35	pendulum mills			1.9	de-scaling crushers			1.4
wire pulls	1.25	1.35	1.5	impact mills			2	lifting tables			1.35
rotary drums				roll mills			1.9	walking beam conveyers			1.5
rotary kilns	1.1	1.25	1.35	roll crushers			1.9	chain transporters			1.4
cooling drums	1.1	1.25	1.35	oil industry				billet shares			1.5
drying drums	1.1	1.25	1.35	filter presses			1.35	cooling beds			1.25
threshers	1.1	1.25	1.35	pipeline pumps			1.35	straightening presses			1.7
conveying plants				scavenging pump			1.35	roll straighteners	1.35	1.6	1.6
shaft sinking machines	1.35	1.5	1.7	paper machines				plate trimming shears			1.4
bucket belts	1.1	1.25	1.25	couchers	1.35	1.5	1.5	winding turret			1.25
rubber belt conveyers light	1	1.1	1.1	horizontal rollers	1.35	1.5	1.6	winding tractors			1.25
rubber belt conveyers heavy	1.1	1.25	1.25	calenders	1.35	1.5	1.5	cropping shears			1.5
band bucket elevators	1	1.1	1.1	glue presses	1.35	1.5	1.6	rope tractors			1.4
trolley conveyers	1.1	1.25	1.25	wet ends	1.35	1.5	1.5	s-roller high speed			1.25
coilers	1.25	1.25	1.25	wet presses	1.35	1.5	1.5	s-rolls, low speed			1.1
bucket chain conveyers	1.25	1.35	1.35	suction formers	1.35	1.5	1.5	roller transporters			1.35
apron feeds	1.25	1.35	1.35	suction rollers	1.35	1.5	1.5	positioning and tilting mech.	1.6	1.9	1.9
Screw conveyers	1.1	1.25	1.35	dry glazing calenders	1.35	1.5	1.6	hot and cold saws			1.5
trough chain conveyers	1.1	1.25	1.35	dry cylinders	1.35	1.5	1.6	live rollertables			1.35
blowers, fans, generators				reversing suction presses	1.35	1.5	1.5	machine tools			
axial blowers	1	1.1	1.25	presses				turning movement	1.1	1.25	1.35
rotary piston blowers	1.1	1.25	1.35	folding presses	1.4	1.4	1.5	planing machines metal	1.25	1.35	1.5
radial blowers	1	1.1	1.25	briquetting presses	1.4	1.4	1.5	horizontal saw-mills	1.35	1.5	1.6
exhaust fans, ind.-drft fans	1.1	1.25	1.35	eccentric presses	1.4	1.4	1.5	wood grinding machines	1.25	1.35	1.5
turbo blowers	1	1.1	1.25	forging presses	1.4	1.4	1.5	centrifuges	1.25	1.36	1.5
light generators	1	1	1.1	brick presses	1.4	1.4	1.5	tackles	1.25	1.3	1.4
generators, pulsating load	1.1	1.25	1.35	pumps							
welding generators	1.35	1.4	1.6	centrifugal pumps, liquids	1	1	1.1				
rubber and plastics machines				centrifugal pumps semiliquids	1.1	1.1	1.25				
extruders	1.25	1.35	1.5	piston pumps(U1:100-200)	1.25	1.35	1.5				
rubber calenders	1.25	1.35	1.5	piston pumps (U<100)	1.4	1.5	1.6				
rubber kneading machines	1.25	1.35	1.5	cargo pumps	1.15	1.25	1.35				
rubber rolling machines	1.25	1.35	1.5	propeller pumps	1.25	1.35	1.5				
mixers	1.25	1.35	1.35	sand pumps	1.15	1.25	1.35				

- Lifting Hole**

The hubs of the couplings from size ED 1600 onwards are supplied with lifting holes to facilitate lifting of coupling.

- Lubrication**

Each coupling half is provided with grease nipple/plug on the housing from where grease can be filled directly. The coupling are supplied with some quality of grease to facilitate assembly. It is recommended to fill the required quality and quantity of grease before putting the coupling in operation.

- Special Protection**

All the components of **ELIGN gear couplings** are applied a special rust preventive oil coating. Besides all the bolts & nuts are zinc/cadmium plated to give protection towards rust & corrosion.

TYPES OF ELIGN GEAR COUPLINGS

The following types are available

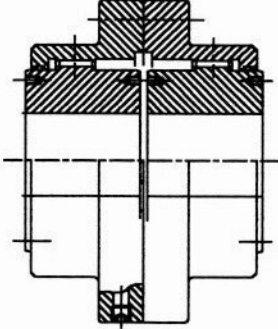
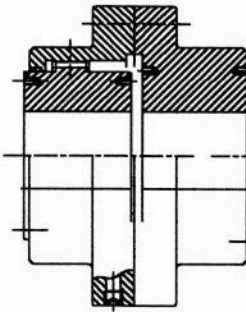
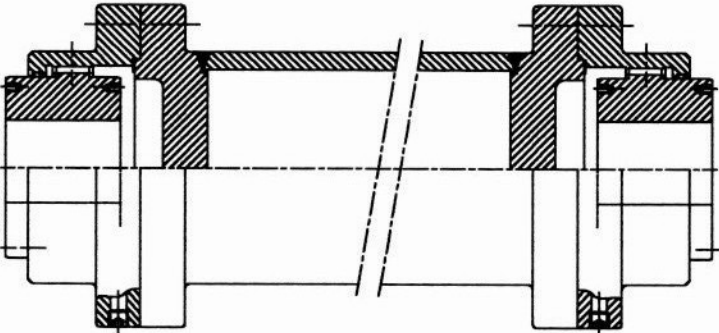
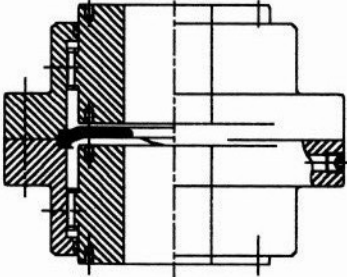
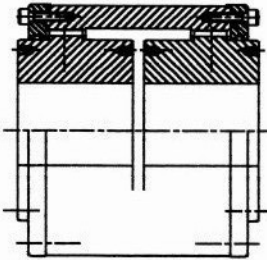
<p>Type ED</p>		<p>With Double housing The couplings are available with bore limitations upto 540 mm and torque ratings upto 110000 da Nm</p>
<p>Type ER</p>		<p>With one end rigid The coupling are available with bore limitations up to 370 mm one side and 410 mm on rigid end and torque ratings upto 45000 da Nm.</p>
<p>Type ET</p>		<p>With Spacer The couplings are available with bore limitations upto 540 mm and torque ratings upto 110000 da Nm</p>
<p>Type EV</p>		<p>For vertical application The couplings are available with bore limitations upto 275 mm and torque ratings upto 17400 da Nm</p>
<p>Type ES</p>		<p>With Single housing The couplings are available with bore limitations from 40 mm to 275 mm and torque ratings from 1600 da Nm to 17400 da Nm</p>

Multi Crowned Toothed Couplings For Shaft Connections

Type ED

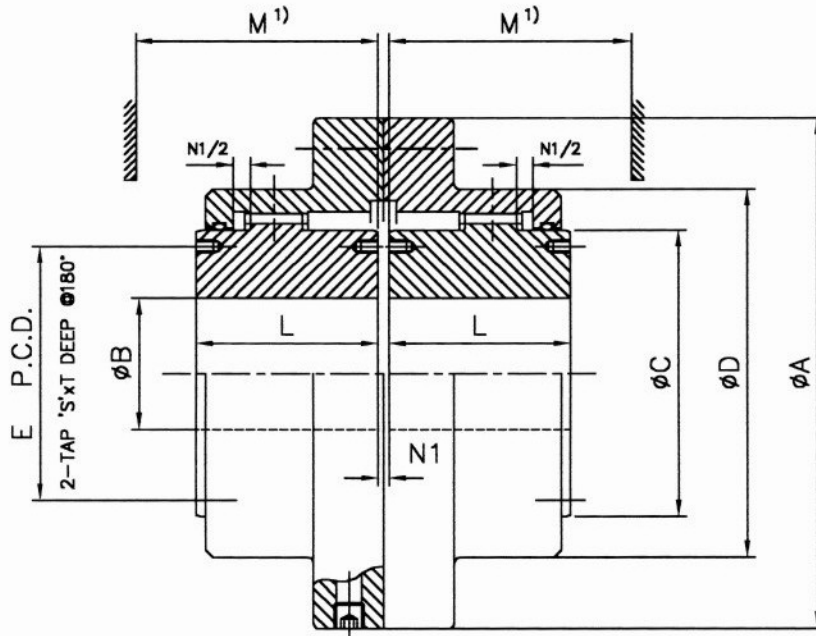

Design 1

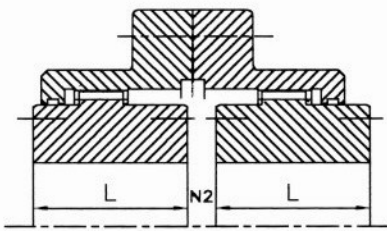

Design 2

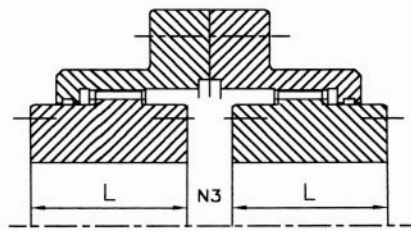

Design 3

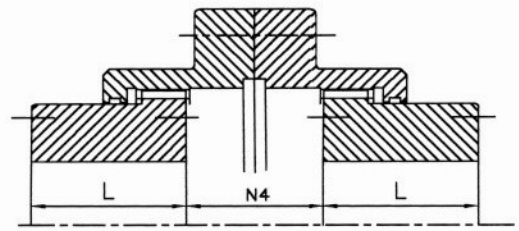

Design 4

SIZE TkN CONTINUOUS	Tk max shock	PkN n conti.	DIAMETER						LENGTH						TAPPING		MISALIGNMENT		WEIGHT kg	MO- MENTS OF INERTIA J (kgm ²)	MAXI- MUM ADM. SPEED 1/min
			A	B			C	D	L	M1	N1	N2	N3	N4	E	SxT	°	± mm			
				PILOT	MIN.	Maxi															
daNm	daNm	kW/rpm	mm						mm						mm		Degree	± mm	kg	J (kgm ²)	1/min
ED 130	260	0.136	111	10	15	45	67	80	43	74	3	12	21	43	—	—	2x0.75	0.35	4	0.005	7000
ED 280	560	0.293	141	15	20	60	87	103.5	50	84	3	9	15	45	—	—	2x0.75	0.4	7	0.015	6200
ED 500	1000	0.524	171	25	30	75	106	129.5	62	105	3	17	31	63	—	—	2x0.75	0.5	14	0.039	5650
ED 1000	2000	1.047	210	30	35	95	130	156	76	123	5	17	29	74	—	—	2x0.75	0.6	25	0.101	5100
ED 1600	3200	1.675	234	35	40	110	151	181	90	148	5	19	33	86	130	M8x12	2x0.75	0.7	37	0.188	4700
ED 2200	4400	2.304	274	50	55	130	178	209	105	172	6	23	40	103	155	M8x12	2x0.75	0.9	60	0.431	4350
ED 3200	6400	3.351	312	60	65	155	213	247	120	193	6	24	42	116	185	M10x15	2x0.75	1.0	90	0.845	4000
ED 4500	9000	4.712	337	75	80	175	235	273	135	215	8	29	50	130	205	M12x18	2x0.75	1.1	118	1.322	3800
ED 6200	12400	6.492	380	85	90	195	263	307	150	241	8	32	56	144	226	M16x24	2x0.75	1.2	169	2.450	3600
ED 8400	16800	8.796	405	95	100	215	286	338	175	279	8	39	70	170	250	M16x24	2x0.75	1.4	224	3.720	3450
ED 11500	23000	12.042	444	115	120	240	316	368	190	304	8	46	84	188	276	M16x24	2x0.75	1.5	277	5.390	3300
ED 17400	34800	18.221	506	145	150	275	372	426	220	339	10	42	74	204	330	M20x30	2x0.75	1.7	414	10.88	3050

1 SPACE REQUIRED TO CHANGE THE SEAL

2 KEYWAYS ACCORDING TO DIN:6885PART-1

3 MAXIMUM ANGULAR MISALIGNMENT PER COUPLING HALF ±0.75°

4 WEIGHT & MOMENT OF INERTIA BASED ON PILOT BORE CONDITION.

5 CONTINUOUS TORQUE RATING SUBJECT TO ACCURATE ALIGNMENT OF CONNECTING SHAFTS.

6 FOR HIGHER SIZE REQUIREMENT SEND REQUEST.

In accordance with our established policy to constantly improve our products, the specifications contained herein are subject to change without notice

Multi Crowned Toothed Couplings For Shaft Connections

Type ED (SUPER SERIES)

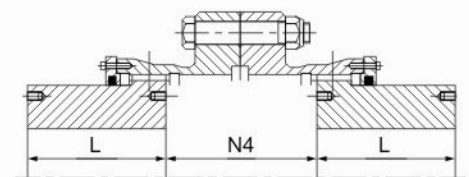
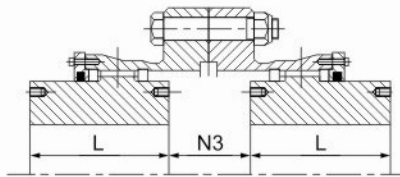
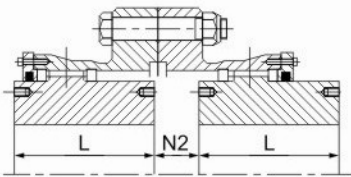
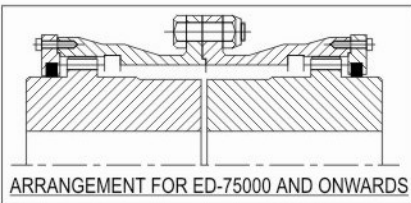
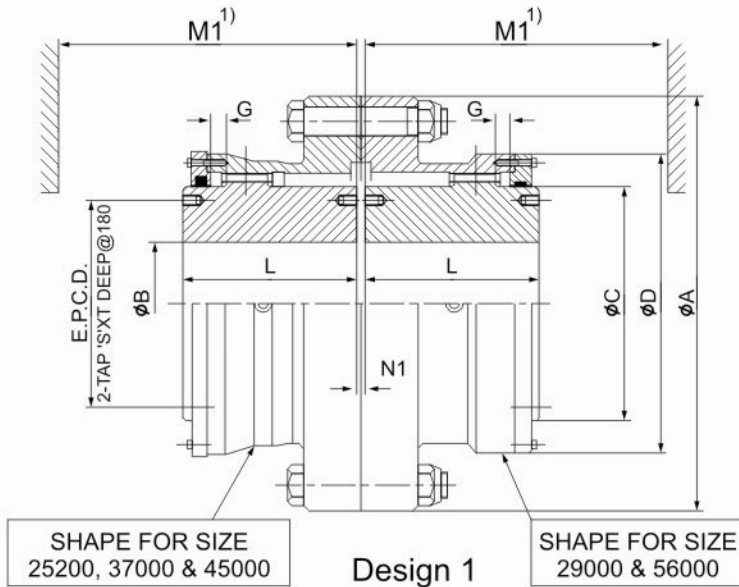

SIZE TkN CONTINUOUS	Tk max shock	Pkn n conti.	DIAMETER						LENGTH						TAPPING		MISALIGNMENT		WEIGHT	MOMENTS OF INERTIA	MAXIMUM ADM. SPEED	
			A	B			C	D	L	G	M1	N1	N2	N3	N4	E	SxT	°				± mm
				PILOT	MIN.	Maxi.																
daNm	daNm	kW/rpm	mm						mm						mm		Degree	± mm	kg	J (kgm ²)	1/min	
ED 25200	50400	26.39	632	155	160	310	422	550	280	10	335	15	119	223	346	360	M20x30	2x0.75	1.8	670	26.75	1830
ED 29000	58000	30.366	640	195	200	320	432	518	292	6.5	324	13	33	53	255	380	M20x30	2x0.75	2.1	760	31	1800
ED 37000	74000	38.746	715	205	210	355	472	616	310	12	370	20	133	246	383	410	M24x40	2x0.75	2.2	930	48	1460
ED 45000	90000	47.123	750	225	230	370	502	648	330	11.5	395	20	144	268	408	435	M24x40	2x0.75	2.2	1110	65.8	1395
ED 56000	112000	58.639	804	275	280	450	594	682	350	6.5	379	13	61	109	335	544	M24x40	2x0.75	2.7	1532	105	1300
ED 75000	150000	78.539	910	285	290	480	620	812	410	10.5	485	25	121	217	*	550	M36x55	2x0.75	3.0	2180	198	1000
ED 90000	180000	94.247	980	315	320	515	670	860	430	15.5	510	25	102	179	*	585	M36x55	2x0.75	3.0	2520	265	940
ED 110000	220000	115.19	1020	325	330	540	700	908	450	16	530	25	97	169	*	615	M36x55	2x0.75	4.0	2910	333	900

- 1 SPACE REQUIRED TO CHANGE THE SEAL
- 2 KEYWAYS ACCORDING TO DIN:6885 PART-1
- 3 MAXIMUM ANGULAR MISALIGNMENT PER COUPLING HALF $\pm 0.75^\circ$
- 4 WEIGHT & MOMENT OF INERTIA BASED ON PILOT BORE CONDITION.
- 5 CONTINUOUS TORQUE RATING SUBJECT TO ACCURATE ALIGNMENT OF CONNECTING SHAFTS.
- 6 FOR HIGHER SIZE REQUIREMENT SEND REQUEST.
- 7 FOR * MARKED DIMENSIONS, PLEASE CONSULT US.

In accordance with our established policy to constantly improve our products, the specifications contained herein are subject to change without notice

Multi Crowned Toothed Couplings For Shaft Connections

Type ER

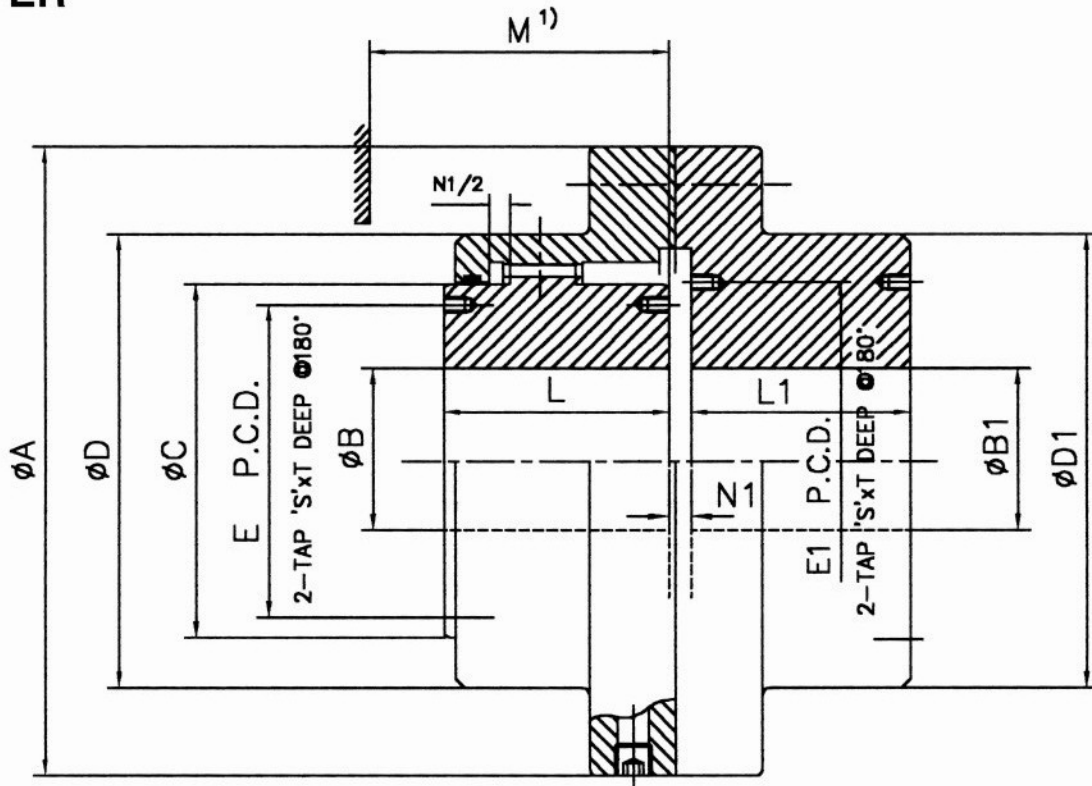

SIZE TKN CONTINUOUS	Tk max shock	P.kN n conti.	DIAMETER									LENGTH				TAPPING			WEIGHT	MO- MENTS OF INERTIA	MAXI- MUM ADM. SPEED		
			A	B			B1			C	D	D1	L	L1	M1	N1	E	E1				SxT	
				PILOT	MIN.	Maxi	PILOT	MIN.	Maxi														Degree
daNm	daNm	kW/rpm	mm									mm				mm							
ER 130	260	0.136	111	10	15	45	10	15	55	67	80	80	43	40	74	5	—	—	—	0.75	4	0.005	7000
ER 280	560	0.293	141	15	20	60	15	20	75	87	103.5	103.5	50	47	84	5	—	—	—	0.75	8	0.015	6200
ER 500	1000	0.524	171	25	30	75	25	30	95	106	129.5	126	62	58	105	5	—	—	—	0.75	14	0.039	5650
ER 1000	2000	1.047	210	30	35	95	30	35	110	130	156	152	76	74	123	6	—	—	—	0.75	26	0.102	5100
ER 1600	3200	1.675	234	35	40	110	35	40	130	151	181	178	90	87	148	6	130	155	M8x12	0.75	38	0.196	4700
ER 2200	4400	2.304	274	50	55	130	50	55	155	178	209	208	105	101	172	6.5	155	180	M8x12	0.75	61	0.450	4350
ER 3200	6400	3.351	312	60	65	155	60	65	180	213	247	245	120	113	193	6.5	185	210	M10x15	0.75	91	0.871	4000
ER 4500	9000	4.712	337	75	80	175	75	80	200	235	273	270	135	129	215	8	205	235	M12x18	0.75	120	1.368	3800
ER 6200	12400	6.492	380	85	90	195	85	90	230	263	307	305	150	150	241	8	226	265	M16x24	0.75	175	2.586	3600
ER 8400	16800	8.796	405	95	100	215	95	100	250	286	338	330	175	175	279	8	250	290	M16x24	0.75	232	3.910	3450
ER 11500	23000	12.042	444	115	120	240	115	120	280	316	368	362	190	190	304	10	276	320	M16x24	0.75	287	5.655	3300
ER 17400	34800	18.221	506	145	150	275	145	150	330	372	426	416	220	220	339	13	330	370	M20x30	0.75	430	11.5	3050

- 1 SPACE REQUIRED TO CHANGE THE SEAL
- 2 KEYWAYS ACCORDING TO DIN:6885 PART-1
- 3 MAXIMUM ANGULAR MISALIGNMENT $\pm 0.75^\circ$
- 4 WEIGHT & MOMENT OF INERTIA BASED ON PILOT BORE CONDITION.
- 5 CONTINUOUS TORQUE RATING SUBJECT TO ACCURATE ALIGNMENT OF CONNECTING SHAFTS.
- 6 FOR HIGHER SIZE REQUIREMENT SEND REQUEST.

In accordance with our established policy to constantly improve our products, the specifications contained herein are subject to change without notice

Multi Crowned Toothed Couplings For Shaft Connections

Type ER (SUPER SERIES)

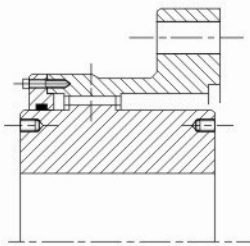
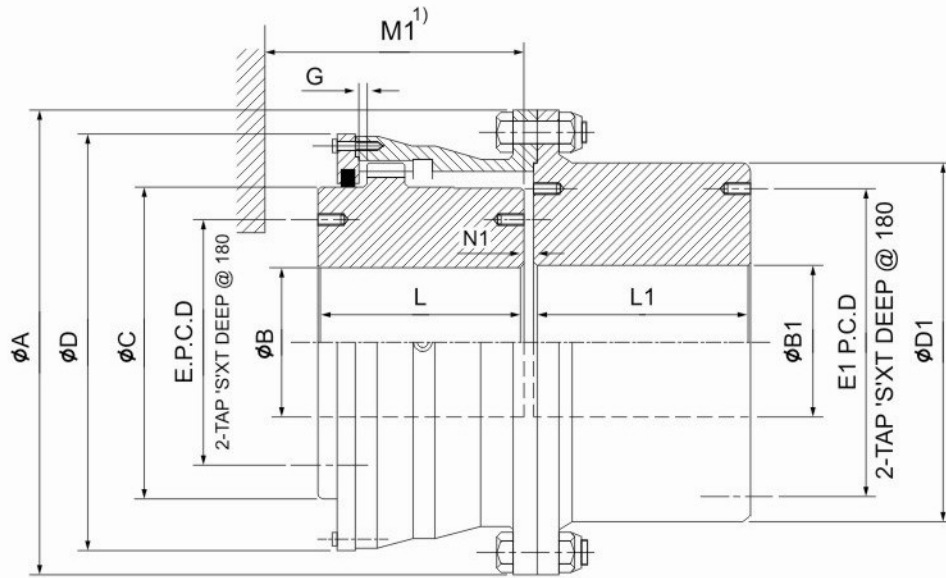

SHAPE OF GEAR HALF FOR
COUPLING SIZE 29000

SIZE TKN CONTINUOUS	Tk max shock	PkN n conti.	DIAMETER										LENGTH					TAPPING			WEIGHT	MOMENTS OF INERTIA	MAXIMUM ADM. SPEED	
			A	B			B1			C	D	D1	L	G	L1	M1	N1	E	E1	SxT				Degree
				PILOT	MIN.	Maxi.	PILOT	MIN.	Maxi.															
daNm	daNm	kW/rpm	mm										mm					mm				kg	(kgm ²)	1/min
ER 25200	50400	26.39	632	155	160	310	155	160	340	422	550	470	280	10	280	335	12	360	395	M20x30	0.75	706	26.17	1830
ER 29000	58000	30.366	640	195	200	320	195	200	365	432	518	512	292	6.5	292	324	14.5	380	455	M20x30	0.75	820	33.53	1880
ER 37000	74000	38.746	715	205	210	355	205	210	380	472	616	535	310	12	310	370	16.5	410	445	M24x40	0.75	984	48.26	1460
ER 45000	90000	47.123	750	225	230	370	225	230	410	502	648	570	330	11.5	330	395	16.5	435	480	M24x40	0.75	1170	64.04	1395

- 1 SPACE REQUIRED TO CHANGE THE SEAL
- 2 KEYWAYS ACCORDING TO DIN:6885 PART-1
- 3 MAXIMUM ANGULAR MISALIGNMENT PER COUPLING HALF $\pm 0.75^\circ$
- 4 WEIGHT & MOMENT OF INERTIA BASED ON PILOT BORE CONDITION.
- 5 CONTINUOUS TORQUE RATING SUBJECT TO ACCURATE ALIGNMENT OF CONNECTING SHAFTS.
- 6 FOR HIGHER SIZE REQUIREMENT SEND REQUEST.
- 7 FOR * MARKED DIMENSIONS, PLEASE CONSULT US.

In accordance with our established policy to constantly improve our products, the specifications contained herein are subject to change without notice

Multi Crowned Toothed Couplings For Shaft Connections

Type ET

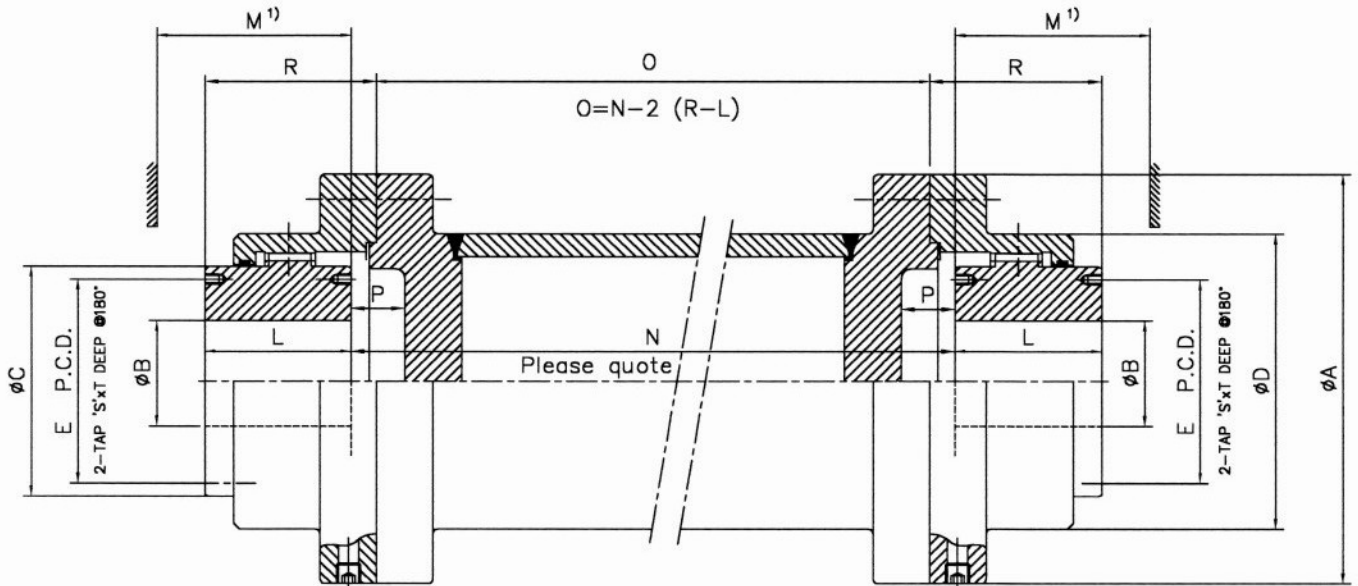

SIZE TkN CONTINUOUS	Tk max shock	PkN n conti.	DIAMETER					LENGTH				TAPPING		MISALIGNMENT		WEIGHT	MO- MENTS OF INERTIA	MAXIMUM ADM. SPEED	
			A	B		C	D	L	M1	P	R	E	SxT		\pm mm				kg
daNm	daNm	kW/rpm	mm					mm				mm		Degree	\pm mm	kg	J (kgm ²)	1/min	
ET 130	260	0.136	111	10	15	45	67	80	43	74	16	53.5	—	—	0.75	1.5	4	0.005	LIMITED BY THE CRITICAL SPEED AND WEIGHT OF THE INTERMEDIATE HOLLOW SHAFT
ET 280	560	0.293	141	15	20	60	87	103.5	50	84	13	57.5	—	—	0.75	1.5	8	0.015	
ET 500	1000	0.524	171	25	30	75	106	129.5	62	104	20	77.5	—	—	0.75	1.5	14	0.039	
ET 1000	2000	1.047	210	30	35	95	130	156	76	123	20	90.5	—	—	0.75	2.5	25	0.101	
ET 1600	3200	1.675	234	35	40	110	151	181	90	148	22	106.5	130	M8x12	0.75	2.5	37	0.188	
ET 2200	4400	2.304	274	50	55	130	178	209	105	172	25	125	155	M8x12	0.75	3	60	0.431	
ET 3200	6400	3.351	312	60	65	155	213	247	120	192	26	141	185	M10x15	0.75	3	90	0.845	
ET 4500	9000	4.712	337	75	80	175	235	273	135	216	31	160	205	M12x18	0.75	4	118	1.322	
ET 6200	12400	6.492	380	85	90	195	263	307	150	241	33	178	226	M16x24	0.75	4	168	2.450	
ET 8400	16800	8.796	405	95	100	215	286	338	175	279	40	210	250	M16x24	0.75	4	224	3.720	
ET 11500	23000	12.042	444	115	120	240	316	368	190	304	47	232	276	M16x24	0.75	4	277	5.390	
ET 17400	34800	18.221	506	145	150	275	372	426	220	339	42	257	330	M20x30	0.75	5.5	414	10.88	

- 1 SPACE REQUIRED TO CHANGE THE SEAL
- 2 KEYWAYS ACCORDING TO DIN:6885 PART-1
- 3 MAXIMUM ANGULAR MISALIGNMENT PER COUPLING HALF $\pm 0.75^\circ$
- 4 WEIGHT & MOMENT OF INERTIA WITHOUT INTERMEDIATE HOLLOW SHAFT.
- 5 CONTINUOUS TORQUE RATING SUBJECT TO ACCURATE ALIGNMENT OF CONNECTING SHAFTS.
- 6 FOR HIGHER SIZE REQUIREMENT SEND REQUEST.

In accordance with our established policy to constantly improve our products, the specifications contained herein are subject to change without notice

Multi Crowned Toothed Couplings For Shaft Connections

Type ET (SUPER SERIES)

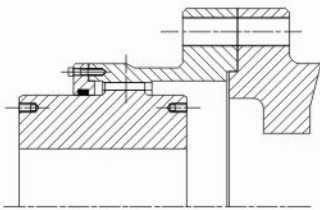
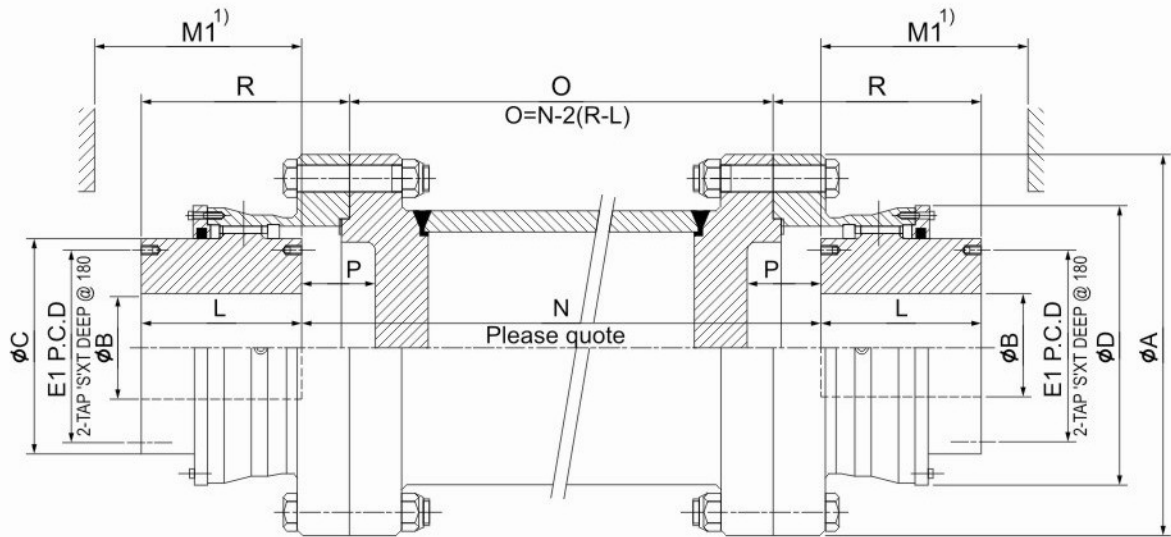

SHAPE OF COUPLING
FOR SIZE 29000 & 56000

SIZE T _k N CONTINUOUS	T _k max shock	P _k N n conti.	DIAMETER						LENGTH				TAPPING		MISALIGNMENT		WEIGHT	MOMENTS OF INERTIA	MAXIMUM ADM. SPEED
			A	B			C	D	L	M1	P	R	E	SxT	Degree	± mm			
				PILOT	MIN.	Maxi.													
daNm	daNm	kW/rpm	mm						mm				mm		Degree	± mm	kg	J (kgm ²)	1/min
ET 25200	50400	26.39	632	155	160	310	422	550	280	335	119	391.5	360	M20x30	0.75	10	670	26.75	LIMITED BY THE CRITICAL SPEED AND WEIGHT OF THE INTERMEDIATE HOLLOW SHAFT
ET 29000	58000	30.366	640	195	200	320	432	518	292	324	33	318.5	380	M20x30	0.75	6.5	760	31	
ET 37000	74000	38.746	715	205	210	355	472	616	310	370	133	433	410	M24x40	0.75	12	930	48	
ET 45000	90000	47.123	750	225	230	370	502	648	330	395	144	464	435	M24x40	0.75	11.5	1110	65.8	
ET 56000	112000	58.639	804	275	280	450	594	682	350	379	61	404.5	544	M24x40	0.75	6.5	1532	105	
ET 75000	150000	78.539	910	285	290	480	620	812	410	485	121	521.5	550	M36x55	0.75	10.5	2180	198	
ET 90000	180000	94.247	980	315	320	515	670	860	430	510	102	523.5	585	M36x55	0.75	15.5	2520	265	
ET 110000	220000	115.19	1020	325	330	540	700	908	450	530	97	539.5	615	M36x55	0.75	16	2910	333	

- 1 SPACE REQUIRED TO CHANGE THE SEAL
- 2 KEYWAYS ACCORDING TO DIN:6885 PART-1
- 3 MAXIMUM ANGULAR MISALIGNMENT PER COUPLING HALF ±0.75°
- 4 WEIGHT & MOMENT OF INERTIA WITHOUT INTERMEDIATE HOLLOW SHAFT.
- 5 CONTINUOUS TORQUE RATING SUBJECT TO ACCURATE ALIGNMENT OF CONNECTING SHAFTS.
- 6 FOR HIGHER SIZE REQUIREMENT SEND REQUEST.

In accordance with our established policy to constantly improve our products, the specifications contained herein are subject to change without notice

Multi Crowned Toothed Couplings For Shaft Connections

Type EV

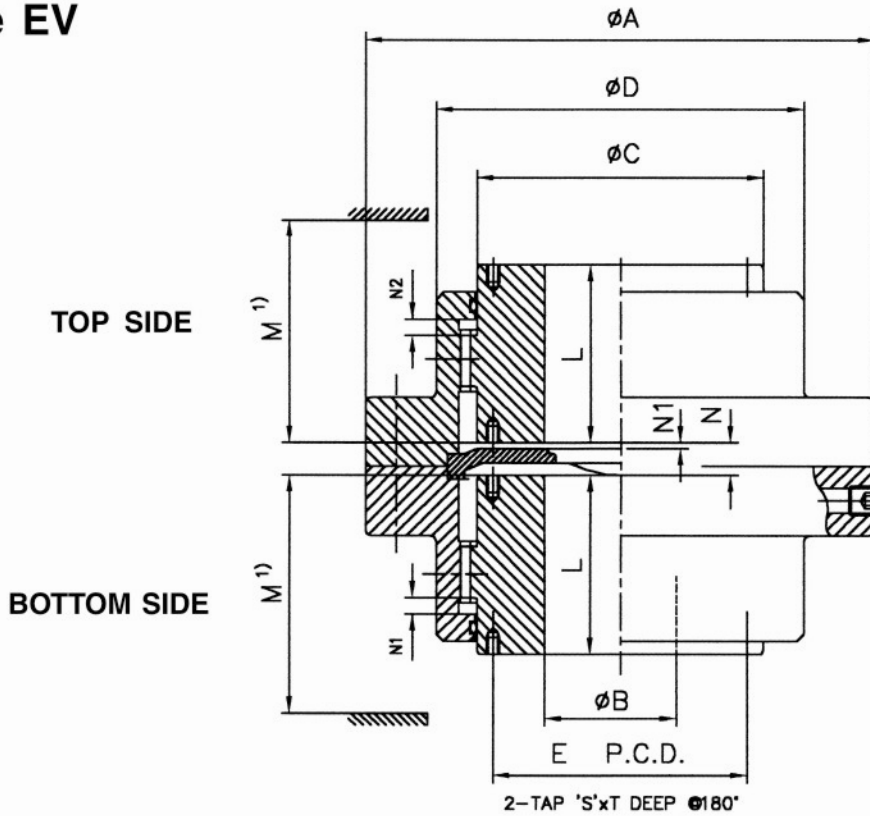

SIZE TkN CONTINUOUS	Tk max shock	PkN n conti.	DIAMETER						LENGTH					TAPPING		MISALIGNMENT		WEIGHT (APPROX) kg	MO- MENTS OF INERTIA J (kgm ²)	MAXI- MUM ADM. SPEED 1/min
			A	B			C	D	L	M1	N	N1	N2	E	SxT					
				PILOT	MIN.	Maxi														
daNm	daNm	kW/rpm	mm						mm					mm	Degree	\pm mm	kg	J (kgm ²)	1/min	
EV 130	260	0.136	111	10	15	45	67	80	43	74	8	1.5	5.5	—	—	2x0.75	0.35	4.5	0.0057	5000
EV 280	560	0.293	141	15	20	60	87	103.5	50	84	5	1.5	5.5	—	—	2X0.75	0.4	8.5	0.017	4400
EV 500	1000	0.524	171	25	30	75	106	129.5	62	105	12.5	1.5	6	—	—	2X0.75	0.5	15	0.043	4000
EV 1000	2000	1.047	210	30	35	95	130	156	76	123	11	2.5	8.5	—	—	2X0.75	0.6	26	0.110	3600
EV 1600	3200	1.675	234	35	40	110	151	181	90	148	13	2.5	8.5	130	M8X12	2X0.75	0.7	39	0.206	3350
EV 2200	4400	2.304	274	50	55	130	178	209	105	172	14	3	12	155	M8X12	2X0.75	0.9	61	0.461	3100
EV 3200	6400	3.351	312	60	65	155	213	247	120	193	15	3	12	185	M10X15	2X0.75	1.0	93	0.935	2800
EV 4500	9000	4.712	337	75	80	175	235	273	135	215	17	4	16	205	M12X18	2X0.75	1.1	122	1.454	2700
EV 6200	12400	6.492	380	85	90	195	263	307	150	241	20	4	16	226	M16X24	2X0.75	1.2	175	2.710	2550
EV 8400	16800	8.796	405	95	100	215	286	338	175	279	27	4	16	250	M16X24	2X0.5*	0.9	236	4.320	2450
EV 11500	23000	12.042	444	115	120	240	316	368	190	304	34	4	16	276	M16X24	2X0.5*	1.0	295	6.480	2300
EV 17400	34800	18.221	506	145	150	275	372	426	220	339	28	5	20	330	M20X30	2X0.5*	1.1	430	11.0	2150

1 SPACE REQUIRED TO CHANGE THE SEAL

2 KEYWAYS ACCORDING TO DIN:6885 PART-1

3 MAXIMUM ANGULAR MISALIGNMENT PER COUPLING HALF $\pm 0.75^\circ$

4 WEIGHT & MOMENT OF INERTIA BASED ON PILOT BORE CONDITION.

5 CONTINUOUS TORQUE RATING SUBJECT TO ACCURATE ALIGNMENT OF CONNECTING SHAFTS.

* MAXIMUM ANGULAR MISALIGNMENT PER COUPLING HALF $\pm 0.5^\circ$

6 FOR HIGHER SIZE REQUIREMENT SEND REQUEST.

In accordance with our established policy to constantly improve our products, the specifications contained herein are subject to change without notice

Multi Crowned Toothed Couplings For Shaft Connections

Type ES

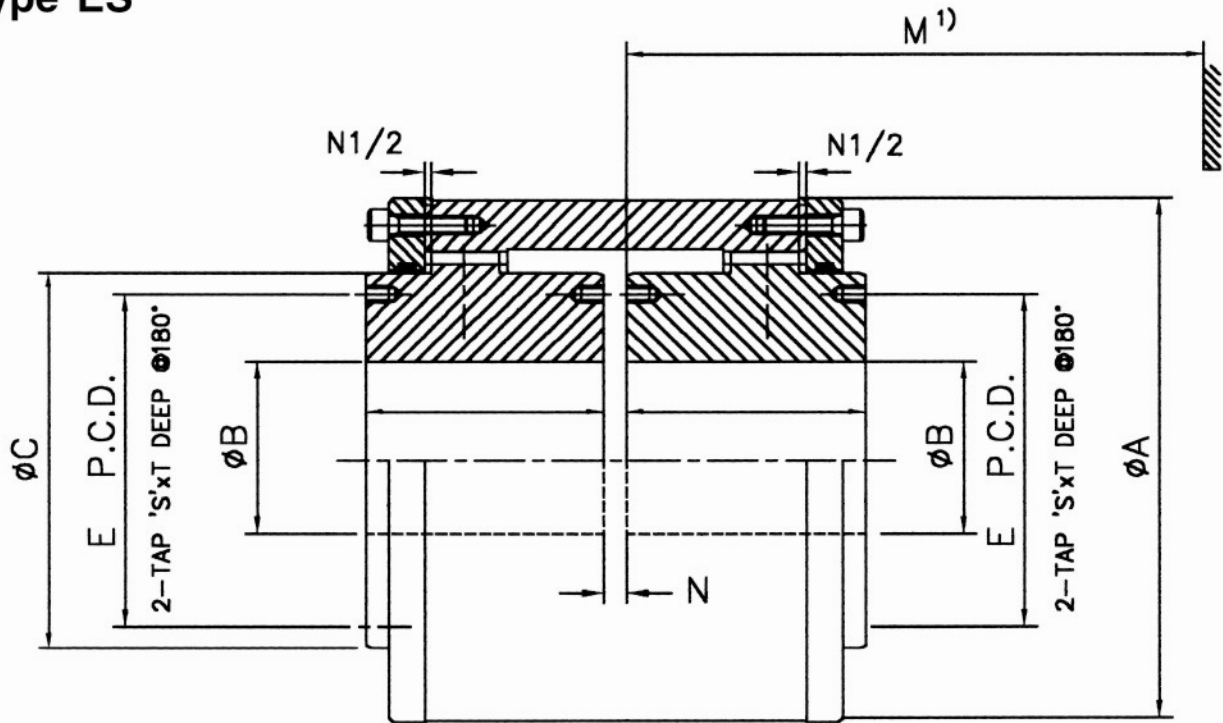

SIZE TkN CONTINUOUS	Tk max shock	PkN n conti.	DIAMETER					LENGTH			TAPPING		MISALIGNMENT		WEIGHT	MOMENTS OF INERTIA	MAXIMUM ADM. SPEED
			A	B			C	L	M1	N	E	SxT	Degree	± mm			
				PILOT	MIN.	Maxi											
daNm	daNm	kW/rpm	mm					mm			mm		kg	J (kgm2)	1/min		
ES 1600	3200	1.675	186	35	40	110	151	90	218	5	130	M8x12	2x0.75	0.7	34	0.158	4700
ES 2200	4400	2.304	216	50	55	130	178	105	257	6	155	M8x12	2x0.75	0.9	52	0.332	4350
ES 3200	6400	3.351	254	60	65	155	213	120	289	6	185	M10X15	2X0.75	1.0	82	0.738	4000
ES 4500	9000	4.712	282	75	80	175	235	135	325	8	205	M12X18	2X0.75	1.1	112	1.255	3800
ES 6200	12400	6.492	317	85	90	195	263	150	358	8	226	M16X24	2X0.75	1.2	154	2.197	3600
ES 8400	16800	8.796	346	95	100	215	286	175	419	8	250	M16X24	2X0.75	1.4	209	3.510	3450
ES 11500	23000	12.042	376	115	120	240	316	190	459	8	276	M16X24	2X0.75	1.5	264	5.352	3300
ES 17400	34800	18.221	436	145	150	275	372	220	513	10	330	M20X30	2X0.75	1.7	398	11.0	3050

- 1 SPACE REQUIRED TO CHANGE THE SEAL
- 2 KEYWAYS ACCORDING TO DIN:6885 PART-1
- 3 MAXIMUM ANGULAR MISALIGNMENT PER COUPLING HALF $\pm 0.75^\circ$
- 4 WEIGHT & MOMENT OF INERTIA BASED ON PILOT BORE CONDITION.
- 5 CONTINUOUS TORQUE RATING SUBJECT TO ACCURATE ALIGNMENT OF CONNECTING SHAFTS.
- 6 FOR HIGHER SIZE REQUIREMENT SEND REQUEST.

In accordance with our established policy to constantly improve our products, the specifications contained herein are subject to change without notice

Notes :

National Branches :

Ahmedabad

Tel: +91 79 26406683/26406684/26406685
 Fax: +91 79 2640 1363
 Email : salesahd@elecon.com

Bangalore

Tel: +91 80-25290082, 25250219, 25252925
 Fax: +91 80-25251834
 Email : salesbgl@elecon.com

Bilaspur

Tel: +91 7752 247723 / 247625
 Fax: +91 7752 247720
 Email : salesbil@elecon.com

Chennai

Tel: +91 44 24349237/24349497/24322455
 Fax: +91 44 2434 9643
 Email : saleschn@elecon.com

Indore

Tele Fax: + 91 731 257 6100
 Email : salesindr@elecon.com

Kolkata

Tel: +91 33 2476 1861 / 2476 0876
 Fax: +91 33 2476 1831
 Email : saleskol@elecon.com

Madurai

Tel: +91 4549 293488
 Email : salesmadu@elecon.com

Nagpur

Tel: +91 712 6642600 / 6642 601
 Fax: +91 712 6642 622
 Email : salesnag@elecon.com

Mumbai

Tel: +91 22 22821315/22820725/22821365
 Fax: +91 22 2287 0791
 Email : salesbom@elecon.com

New Delhi

Tel: +91 11 2341 4340 / 2341 4341
 Fax: +91 11 2370 9046
 Email : salesdel@elecon.com

Pune

Tel: +91 20 4019 1400
 Fax: +91 20 4019 1411
 Email : salespune@elecon.com

Raipur

Tele Fax: +91 771 2259 321 /23/24/30
 Email : salesrai@elecon.com

Hyderabad

Tele Fax: +91 40 64561199
 Email : salessec@elecon.com

Vadodara

Tel: +91 265 2313 670
 Tele Fax: 91 265 2312 972 / 2312 980
 Email : salesvad@elecon.com

Vallabh Vidyanagar

Tel. +91 02692-231125 / 227559/227549/ 227560
 E mail : salesvvn@elecon.com

International Network :

MIDDLE EAST :

ELECON MIDDLE EAST FZCO, Dubai

Phone : +97 146 091 424, +97 146 091 425
 Fax : +97 146 091 426
 E-mail : salesme@elecon.com

FAR EAST :

ELECON SINGAPORE PTE. LTD.

Phone : +65 622 782 58
 Fax : +65 622 789 42
 E-mail : salesap@elecon.com



AUSTRALIA

Radicon Transmission
 (Australia) Pty. Ltd.
 Tel: +61 488 054 028
 Fax: +61 295 213 522
 salesap@elecon.com
 www.radicon.com

UNITED KINGDOM

Radicon Transmission UK LTD.
 Tel: +44 (0)1484 465800
 Fax: +44 (0)1484 465801
 sales@radicon.com
 www.radicon.com

THAILAND

Radicon Transmission Thailand Ltd.
 Tel : +66 38 459 044
 Fax: +66 38 213 655
 salesap@elecon.com
 www.radicon.com

UNITED STATES OF AMERICA

RADICON USA
 Tel. 1-847-593-9910
 Fax. :1-847-593-9950
 salesusa@radicon.com
 www.radicon.com

MIDDLE EAST

Radicon Transmission FZE
 Tel: + 97165527950
 Fax: + 97165527951
 radicon@eim.ae
 www.radicon.com



SWEDEN

AB Benzlers
 Tel: + 46 42 18 68 00
 Fax: + 46 42 21 88 03
 info@benzlers.com
 www.benzlers.com

NETHERLANDS

Benzler-TBA BV
 Tel : +31 077 324 5900
 Fax: +31 077 324 5901
 mail@benzlers.com
 www.benzlers.com

GERMANY

Benzler Antriebstechnik
 Gmbh
 Tel: +49 0800 350 4000
 Fax: +49 0800 350 4001
 mail@benzlers.com
 www.benzlers.com

FINLAND

O.Y. Benzler AB
 Tel: +358 9 340 1716
 Fax: +358 10 296 2072
 info@benzlers.com
 www.benzlers.com

DENMARK

Benzler Transmission A/S
 Tel: +45 36 34 0300
 info@benzlers.com
 www.benzlers.com

