

radicon



with you at every turn

benzlers



with you at every turn

Series C Helical Worm

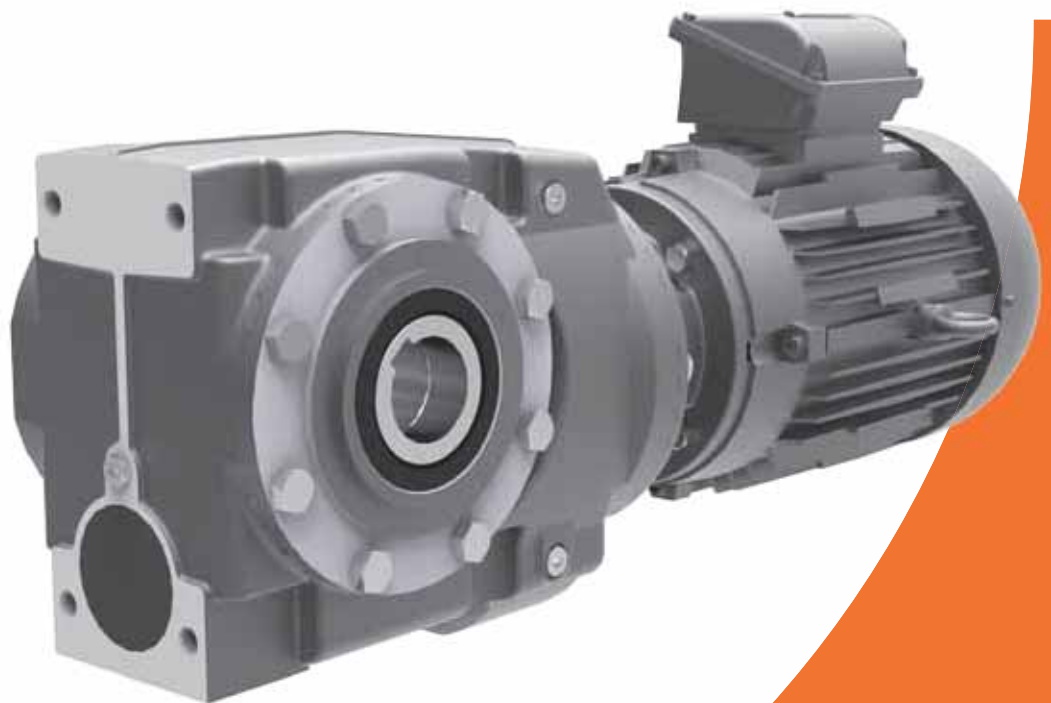

Technical
Up to - 45 Kw / 10,000 Nm

Geared Motors
CC-2.01GB0914

PRODUCTS IN THE RANGE

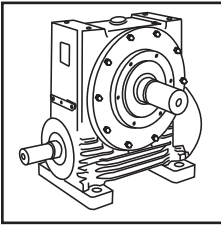

Series A
Worm Gear units
and geared motors
in single & double
reduction types

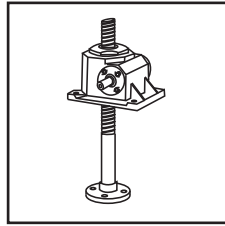

Series BD
Screwjack worm
gear unit

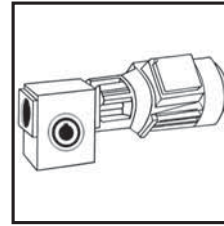

Series BS
Worm gear unit

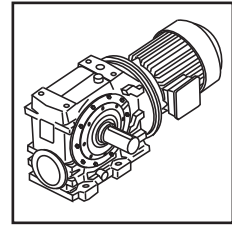

Series C
Right angle drive
helical worm geared
motors & reducers

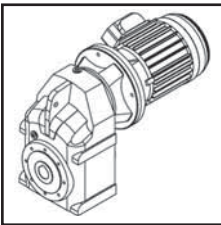

Series F
Parallel shaft helical
geared motors &
reducers

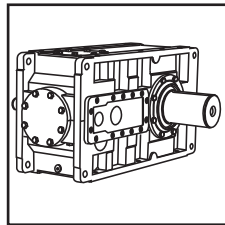

Series G
Helical parallel shaft
& bevel helical right
angle drive gear
units

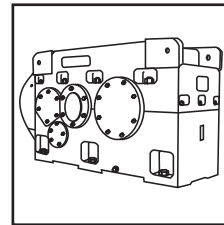

Series H
Large helical parallel
shaft & bevel helical
right angle drive units

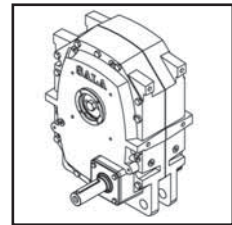

Series J
Shaft mounted
helical speed
reducers

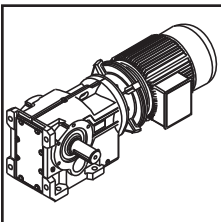

Series K
Right angle helical
bevel helical geared
motors & reducers

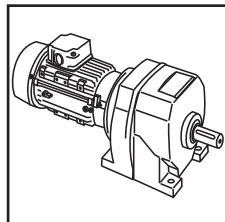

Series M
In-line helical geared
motors & reducers

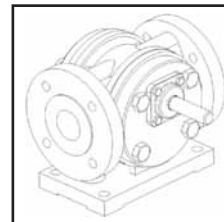

Roloid Gear Pump
Lubrication and fluid
transportation pump

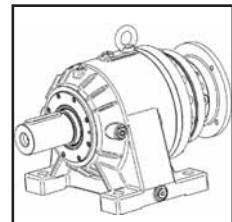

Series P
Planetary
Foot and flange
mounted planetary
units

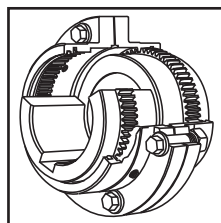

Series X
Elign Gear
Torsionally rigid,
high torque coupling

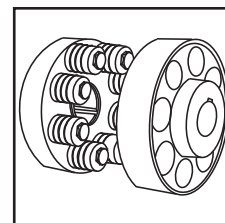

Series X
Elflex
Pin and bush
elastomer coupling

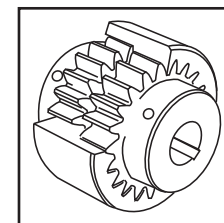

Series X
Nylicon
Gear coupling with
nylon sleeve

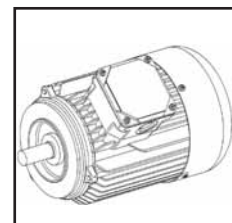

Motors
Full range of IEC
motors



We offer a wide range of repair services and many years experience of repairing demanding and highly critical transmissions in numerous industries.

We can create custom engineered transmission solutions of any size and configuration.

SERIES C

CONTENTS

General Description _____	2
Unit Designations _____	3
Explanation and use of Ratings and Service Factors _____	4
Load Classification by Applications _____	5
Selection Procedure _____	6 - 7
Output Options _____	8 - 9
Motor Adaptors _____	10 - 12
Lubrication _____	13
Mounting Positions _____	14
Unit Handlings _____	15
MOTORISED	
Motor Performance Data and Standard Motor Variants Available _____	18
Motor Details _____	19
Additional Motor Features _____	20
Additional Gearbox Features _____	21
Selection Tables - Geared Motors _____	22 - 61
Dimension Sheets - Geared Motors _____	62 - 69
Dimensions Output Options _____	70
Motorised Backstop Module _____	71
REDUCER	
Overhung & Axial Loads on Shafts _____	74
Ratings - Input Power / Output Torque _____	75 - 82
Dimension Sheets - Speed Reducers _____	83 - 88
Dimension Sheet - Units fitted with Feet _____	89 - 90
Thermal Power Ratings / Dimensions of Unit with Fan _____	91 - 92
Reducer Backstop Module _____	93
OUTPUT OPTIONS	
Dimensions of Outputshaft Options _____	94
Dimension Sheet - Torque Bracket _____	95
Dimensions of B5 (D) Flange units _____	96
Dimensions of B14 (C) Flange units _____	97
Agitator Units _____	98
Dimension Sheet - Assembly / Disassembly _____	99 - 100
Shipping Specification _____	101
Product Safety Data _____	102

SERIES C

GENERAL DESCRIPTION

Series C

right angle helical worm geared motors and reducers provide a highly efficient and compact solution to meet most requirements up to 45 kW with maximum output torque capacity of 10,000Nm.

Following a long line of power transmission products, this product adds to the growing family of new drives which has taken advantage of our many years of accumulated design expertise, together with the use of high quality materials and components. The end result is a series of speed reducing and geared motors offering high load carrying capacity, increased efficiency, quiet running and reliability.

The Range Includes

Eight sizes of units with a ratio coverage of 8:1 to 250:1 in double reduction and 16000:1 in combined units.

- Version W - Standard Unit (C03 - C06 Only)
- Version B - Standard Unit with Base Mounted Feet
- Version E - Standard Unit with End Mounted Feet
- Version R - Standard Unit with Top Mounted Feet
- Version V - Standard Unit with Drywell and Output Flange for Mounting Positions 2 & 3 (sizes C07 - C10 only)
- Version F/H - Standard Unit with Output Flange
- Version G - Standard Unit with Output Flange Reduced Diameter (size C03 only)
- Version T/Q - Standard Unit with Torque Arm
- Version U - Standard Unit Torque Arm Heavy Duty (C10 only)
- Version A - Agitator (Sizes C07 - C10 only)

Unit Types:

- Unit type M - Motorised with IEC Standard Motor
- Unit type D - Motorised with Compact Motor
- Unit type N - Motorised with NEMA Standard Motor
- Unit type H - Motorised with High Efficiency Motor (IE3)
- Unit type E - Motorised with NEMA High Efficiency Motor (PREMIUM)
- Unit type G - Unit to Allow Fitting of Customers IEC Motor
- Unit type A - Unit to Allow Fitting of Customers NEMA Motor
- Unit type R - Reducer Unit
- Unit type S - Reducer Unit with Fan Kit
- Unit type W - Reducer Unit with Backstop CCW Rotation
- Unit type X - Reducer Unit with Backstop CW Rotation
- Unit type Y - Reducer Unit with Fan and Backstop CW Rotation
- Unit type Z - Reducer Unit with Fan and Backstop CCW Rotation

Design Features Include

Patented standard motor connection (IEC or NEMA).

Ability to fit double oil seals input and output as required.

All units are dimensionally interchangeable with other major manufacturers.

Brake geared motors are available as standard.

Sizes 03, 04, 05 and 06 are lubricated for life.

Motorised units can be fitted with a backstop module and reducer units can be fitted with a backstop and fan.

Units are manufactured and assembled from a family of modular kits for distributor friendliness minimising inventory and maximising availability.

As improvements in design are being made continually this specification is not to be regarded as binding in detail and

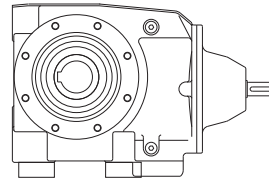

Two stage reduction unit with base mounted feet and hollow output shaft

* C 0 4 2 1 1 8 . B R H - 1 - - - - -

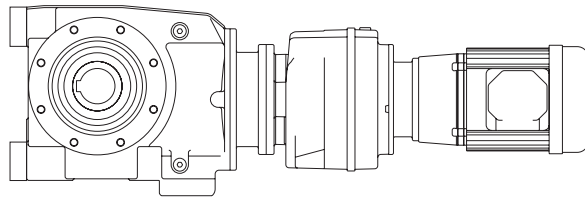

Four stage motorised unit with end mounted feet and hollow output shaft

* C 0 4 4 1 2 8 0 E M H - 1 A . 1 8 A - -

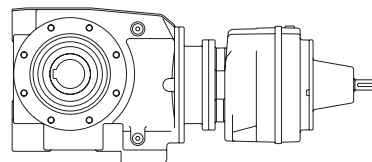

Four stage reduction unit with hollow output shaft

* C 0 5 4 1 2 8 0 W R H - 1 - - - - -

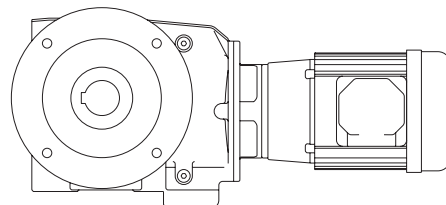

Two stage motorised unit with output flange and single extension output shaft

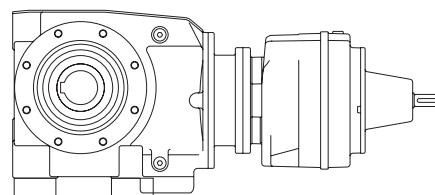

Four stage reduction unit with base mounted feet and hollow output shaft

* C 0 4 4 1 2 8 0 B R H - 1 - - - - -

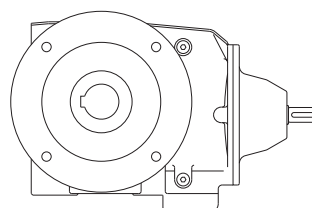

Two stage reduction unit with output flange and single extension output shaft

* C 0 5 2 1 1 6 0 F R C - 1 - - - - -

* Typical unit designations

SERIES C

Gear codes													Motor codes						
1	2	3	4	5	6	7	8	9	10	11	12	13	14	15	16	17	18	19	20
* <input type="text" value="C"/>																			
Example <input type="text" value="C032150.BMC-1D.18A--"/>																			

1 - Series C

Range

2, 3 - Size of Unit
Through

4 - No of Reductions

5 - Revision Version
 For Sizes 03 to 10

6,7,8 - Nominal Overall Ratio
eg.

9 - Unit Version

- Standard Unit (C03 - C06 Only)
 - Standard Unit with Base Mounted Feet
 - Standard Unit with End Mounted Feet
 - Standard Unit with Top Mounted Feet
 - Standard Unit with Drywell and Output Flange
 For Mounting Position 2 & 3 (Sizes C07 - C10 only)
 Std Unit with Output Flange on Left on Right
 - Std Unit with Output Flange Reduced Dia (C03 Only)
 Std Unit with Torque Arm on Left on Right
 - Std Unit with Torque Arm - Heavy Duty (C10 Only)

10 - Type of Unit

- Motorized with IEC standard motor (IE2)
 - Motorized with Compact motor
 - Motorized with NEMA standard motor (EPACT)
 - Motorized with IEC high efficiency motor (IE3)
 - Motorized with NEMA high efficiency motor (PREMIUM)
 - Unit to allow fitting of IEC motor (customer own motor)
 - Unit to allow fitting of NEMA motor (customer own motor)
 - Reducer unit
 - Reducer unit with fan kit
 - Reducer unit with backstop CCW rotation
 - Reducer unit with backstop CW rotation
 - Reducer unit with fan and backstop CW rotation
 - Reducer unit with fan and backstop CCW rotation

15, 16, 17 - Geared Motor Powers
Motor Power Required
eg
For Reducer or Non-Standard
Motor Types Enter

12 - Motor Adaptor For Unit Types
Column 10 Entries M, N, H, E, G or A
For All Other Types Enter

13, 14 - Mounting Position
eg

11 - Output Shaft

Standard Single Extension on Left on Right
 Standard Double Extension
 Extended Shaft for Flange Mounted Units
 Standard Hollow Shaft
 Unit with Hollow Shaft with Reduced Bore Dia
 Heavy Duty Single Extension (Size C06)
 Heavy Duty Double Extension (Size C06)

18 - No of Motor Features

<input type="text" value="-"/> No motor	50 Hz	60 Hz
4 Pole (Std) 1500 rpm	<input type="text" value="A"/>	1800 rpm <input type="text" value="B"/>
4 Pole (High) 1500 rpm	<input type="text" value="K"/>	1800 rpm <input type="text" value="L"/>
6 Pole (Std) 1000 rpm	<input type="text" value="C"/>	1200 rpm <input type="text" value="D"/>
6 Pole (High) 1000 rpm	<input type="text" value="M"/>	1200 rpm <input type="text" value="N"/>
2 Pole 3000 rpm	<input type="text" value="E"/>	3600 rpm <input type="text" value="F"/>
8 Pole 750 rpm	<input type="text" value="G"/>	900 rpm <input type="text" value="H"/>
<input type="text" value="S"/> Dual Speed or Special Motor		

19 - Additional Motor Features
eg
For Types Without Motor Enter

20 - Additional Gearbox Features
Double Oil Seal, Motorised Backstop Etc
eg

* This page may be photocopied allowing the Customer to enter their order

SERIES C

EXPLANATION & USE OF RATINGS & SERVICE FACTORS

Gear unit selection is made by comparing actual loads with catalogue ratings. Catalogue ratings are based on a standard set of loading conditions, whereas actual load conditions vary according to type of application. Service Factors are therefore used to calculate an equivalent load to compare with catalogue ratings.

i.e. Equivalent Load = Actual Load x Service Factor

Mechanical ratings and service factor Fm

Mechanical ratings measure capacity in terms of life and/or strength, assuming 10 hr/day continuous running under uniform load conditions.

Catalogue ratings allow 100% overload at starting, braking or momentarily during operation up to 10 hours per day.

The unit selected must therefore have a catalogue rating at least equal to half maximum overload.

Mechanical Service Factor Fm (Table 1) is used to modify the actual load according to daily operating time, and type of loading.

Load characteristics for a wide range of applications are detailed in Table 3 opposite, which are used in deciding the appropriate Service Factor Fm from Table 1.

If overloads can be calculated, or accurately assessed, actual loads should be used instead of Fm.

For units subjected to frequent stop/starts overloads in excess of 10 times/day multiply factor Fm x Factor Fs (table 2).

Table 1. Mechanical Service Factor (Fm)

Prime Mover	Duration of service hrs Per day	Load classification- driven machine		
		Uniform mass acceleration factor < 0.2	Moderate mass acceleration factor < 0.3	Heavy acceleration factor < 10
Electric Motor, Steam Turbine, or Hydraulic Motor	< 3	0.80	1.00	1.50
	3 - 10	1.00	1.25	1.75
	> 10	1.25	1.50	2.00
Multi-cylinder internal combustion engine	< 3	1.00	1.25	1.75
	3 - 10	1.25	1.50	2.00
	> 10	1.50	1.75	2.25
single cylinder internal combustion engine	< 3	1.25	1.50	2.00
	3 - 10	1.50	1.75	2.25
	> 10	1.75	2.00	2.50

Mass acceleration factor = $\frac{\text{all external moments of inertia}^*}{\text{moment of inertia of driving motor}}$

* calculated with reference to the motor speed

Table 2. Number of Starts Factor (Fs)

Starts/ stops per hour	< 1	5	10	40	60	> 200
Factor FS	1.00	1.03	1.06	1.10	1.15	1.20

Note: (1) Intermediate values are obtained by linear interpolation

Thermal Rating (For In-line Reducers)

The Thermal Rating is the gearboxes ability to dissipate heat. If exceeded, may cause the lubricant to break down resulting in premature gear failure. A thermal check should be made in accordance with the Thermal Rating Procedure

SERIES C

LOAD CLASSIFICATION BY APPLICATION

Load Classifications - U =Uniform Load M =Moderate Shock Load H =Heavy Shock Load † =Consult our Engineers

Agitators		Elevators		Machine Tools		Pumps	
Pure liquids	U	Bucket - Uniform load	U	Bending roll	M	Centrifugal proportioning	U
Liquids and solids	M	Bucket - Heavy load	M	Punch press	H	Proportioning	M
Liquids variable density	M	Bucket - Continuous	U	Notching press	H	Reciprocating	
		Centrifugal discharge	U	Plate planer	H	Single acting 3+ cylinders	M
Blowers		Escalators	U	Other machine tools		Double acting 2+ cylinders	M
Centrifugal	U	Freight	M	Main drive	M	Single acting 1 & 2 cylinders	†
Lobe	M	Gravity discharge	U	Aux drive	U	Double acting 1 cylinder	†
Vane	U	Passenger lifts	†			Rotary- gear type	U
				Metal mills		Rotary- lobe type/ vane	U
Brewing & distilling		Fans		Carriage/main drive	M		
Bottling machinery	M	Centrifugal	U	Draw bench	M	Sand muller	M
Brew Kettles	M	Cooling towers		Dryer	M		
Cookers	M	Induced draft	†	Flattening machinery	M	Sewage treatment	
Mash tubs	M	Forced draft	†	Pinch drive	M	Bar screen	U
Scale hopper	M	Fan - Large diameter induced draft	M	Reversing slitters	M	Chemical feeder	U
		Fan - Light, small diameter	M	Scrubber rolls	M	Collector	U
				Table conveyors		Dewatering screw	M
Can filling machinery	M	Feeders		Group drives	H	Mixers	M
		Apron	M	Individual drives	H	Scum breaker	M
Crane knife	M	Belt	M	Table conveyors- reversing	H	Thickness	M
		Disc	U	Wire draw	M	Vacuum filters	M
Car dumper	M	Reciprocating	H	Wire roll	M		
		Screw	M			Screens	
Car puller	M			Mills		Air washing	U
		Food industry		Cement kiln	H	Rotary, stone or gravel	M
Clarifier	U	Cereal cooker	U	Dryer, Cooler	H	Traveling water intake	U
		Dough mixer	M	Kiln (other)	H		
Classifier	M	Meat grinder	M	Rod plain	H	Slab pushers	M
		Meat slicer	M	Rod wedge bar	H		
Clay wokring machinery		Generators - not welding	U	Rotary/ Ball	H	Slewing	H
Brick press	H			Tumbling barrel	H		
Briquette machine	H	Hammer mills	H			Steering gear	†
Clay working machinery	M			Mixers			
Plug mill	M	Hoists		Concrete	M	Stokers	U
		Heavy duty	H	Cons density	U		
Compressors		Medium duty	M	Variable density	M	Sugar industry	
Centrifugal	U	Skip hoist	M			Can knife	M
Lobe	M			Oil industry		Crusher	M
Reciprocating		Laundry		Chiller's	M	Mills	M
Multi cylinder	M	Tumbler	M	Oil well pump	M		
Single cylinder	H	Washer	M	Filter press	M	Textile industry	
				Rotary kiln	M	Batchers	M
Conveyors- Light duty uniform load		Line shafts				Calenders	M
Apron	U	Heavy duty	M	Paper industry		Cards	M
Assembly	U	Light duty	U	Agitator (mixer)	M	Dry cans	M
Belt	U			Barker (hydraulic)	M	Dryers	M
Bucket	U	Lumber industry		Barker (mechanical)	H	Dyeing machinery	M
Chain	U	Barkers	M	Barking drum	H	Knitting machinery	M
Flight	U	Burner conveyor	H	Beater & Pulper	M	Looms	M
Oven	U	Chain/ Drag saw	H	Bleacher	U	Mangles	M
Screw	U	Chain transfer	H	Calendnders	M	Nappers	M
		Chain way transfer	H	Calenders- super	H	Pads	M
Conveyors - Heavy duty uniform load		Chain barkng drum	H	Converting machine	M	Range drive	M
Apron	M	Edger feed	M	Conveyors	U	Slashers	M
Assembly	M	Gang feed	M	Couch	M	Soapers	M
Belt	M	Green chain	M	Cutters - plates	H	Spinners	M
Bucket	M	Live roll	M	Cylinders	M	Tenter frame	M
Chain	M	Log deck	H	Dryers	M	Washers	M
Flight	M	Log haul	H	Felt stretcher	M	Winders	M
Live roll	†	Log turning	H	Felt whipper	H		
Oven	M	Log conveyoy	H	Jordans	M	Windlass	†
Reciprocating	M	Of bearing roll	M	Log haul	H		
Screw	M	Planer feed chaines	M	Machine real	M		
Shaker	M	Planer hoist	M	Presses	M		
		Re-saw conveyor	M	Stock chest	M		
Cranes	†	Roll cases	H	Suction roll	M		
		Slab conveyor	H	Washers & thickeners	M		
Crusher		Sorting table - triple hoist	M	Winders	M		
Ore	H	Triple hoist - Drive /conveyor	M			Printing presses	†
Stone	H	Transfer conveyor	M				
Sugar	H	Transfer roll	M	Pullers			
		Tray drive	M	Barge haul	H		
Dredger	M	Trimmer feed	M				
Cable reals	M	Waster conveyor	M				
Conveyors	M	Small waste conveyor (belt)	U				
Cutter head drive	H	Small waste conveyor (chain)	U				
Pumps	M						
Screen drive	H						
Stackers	M						
Winches	M						

SERIES C

SELECTION PROCEDURE FOR MOTORISED UNITS

EXAMPLE APPLICATION DETAILS

Absorbed power of driven machine = 0.7 kW
 Output speed of gearbox or Input speed of machine = 68 rev/min
 Application = Uniformly loaded belt conveyor
 Duration of service (hours per day) = 24hrs
 Mounting position = 1
 Ambient temperature = 20°C
 Running time (%) = 100%

Note!
 If you select a Series C Reducer for use without TEFC motor, A thermal check must be made.

1 DETERMINE MECHANICAL SERVICE FACTOR (Fm)

Refer to Load Classification by Application, table 3, page 6
 Application = Uniformly loaded belt conveyor
Conveyors-uniformly loaded or fed

apron	U	U = Uniform load
assembly	U	
belt	U	
bucket	U	
chain	U	

Refer to mechanical service factor (Fm)
 Duration of service (hours per day) = 24hrs

Prime mover	Duration of services per day	Load classification	
		Uniform	Moderate
Electric motor, steam turbine or hydraulic motor	< 3	0.80	1.00
	3 - 10	1.00	1.25
	> 10	1.25	1.50

Therefore mechanical service factor (Fm) = 1.25
 If the unit is subject to frequent start/stops Fm must be multiplied by factor Fs

2 DETERMINE REQUIRED OUTPUT TORQUE AT GEARBOX OUTPUT SHAFT

Absorbed output torque = $\frac{\text{Absorbed power} \times 9550}{\text{Gearbox output speed}}$

$\frac{0.7 \times 9550}{68} = 98 \text{ Nm}$

3 SELECT GEARED MOTOR

Refer to selection table one motor size larger than absorbed power.
 Absorbed power = 0.7 kW, therefore refer to 0.75 kW selection table.
 Always select from 4 POLE selection table in the first instance as this offers a more economical solution.
 Required output speed of gearbox = 68 rev/min

0.75 kW	N2 R/MIN	i	M2 Nm	Fm	N	UNIT DESIGNATION	Kg	
4 POLE	Output Speed	Ratio	Output Torque	Service Factor	Overhung Load	Column Entry 1 Through 20 Spaces to be filled when entering order	Weight of Base Mount Unit	Motor Frame Size
	165	8.59	36	2.24	2841	C 0 3 2 1 8 . 0 _ M _ _ _ . 7 5 A - -	19.5	80A
	122	11.61	48	1.81	2837	1 1 .		
	107	13.20	54	1.65	2832	1 2 .		
	95	14.95	62	1.51	2832	1 4 .		
	86	16.36	60	1.44	2827	1 6 .		
	74	19.12	78	1.27	2821	1 8 .		
	69	20.61	84	1.2	2821	2 0 .		
	64	22.11	80	1.18	2821	2 2 .		
	56	25.14	90	1.08	2810	2 5 .		
	50	28.48	101	1	2810	2 8 .		

Go to point 4

SERIES C

SELECTION PROCEDURE FOR MOTORISED UNITS

4 CHECK OUTPUT TORQUE

Output torque (M2) of selected unit must be equal or more than required output torque at gearbox outputshaft.

Required output torque at gearbox outputshaft = 98 Nm.

0.75 kW 4 POLE	N2 R/MIN	i	M2 Nm	Fm	N	UNIT DESIGNATION	Kg	
	Output SPEED	Ratio	Output Torque	Service Factor	Overhung Load	Column Entry <input type="text" value="1"/> Through <input type="text" value="20"/> Spaces to be filled when entering order	Weight of Base Mount Unit	Motor Frame Size
	74	19.12	78	1.27	2821	C 0 3 2 1 1 8 . _ M _ _ _ . 7 5 A _ _	19.5	80A
69	20.61	84	1.2	2821	2 0 .			
64	22.11	80	1.18	2821	2 2 .			

However the output torque is only 84 against the requirement of 98 Nm, hence a unit fitted with a 1.1 kW motor is required

1.1 kW 4 POLE	N2 R/MIN	i	M2 Nm	Fm	N	UNIT DESIGNATION	Kg	
	Output SPEED	Ratio	Output Torque	Service Factor	Overhung Load	Column Entry <input type="text" value="1"/> Through <input type="text" value="20"/> Spaces to be filled when entering order	Weight of Base Mount Unit	Motor Frame Size
	74	19.12	115	0.86	2800	C 0 3 2 1 1 8 . _ M _ _ _ 1 - 1 A _ _	24.5	90S
68	20.61	123	0.82	2800	2 0 .			
64	22.11	117	1.8	2800	2 2 .			

Selected unit's output torque (M2) = 123 Nm, therefore the torque from a 1.1 kW motor is acceptable.

5 CHECK SERVICE FACTOR

Service factor (Fm) of selected unit must be equal or more than required service factor.

Required service factor of gearbox = 1.25

1.1 kW 4 POLE	N2 R/MIN	i	M2 Nm	Fm	N	UNIT DESIGNATION	Kg	
	Output SPEED	Ratio	Output Torque	Service Factor	Overhung Load	Column Entry <input type="text" value="1"/> Through <input type="text" value="20"/> Spaces to be filled when entering order	Weight of Base Mount Unit	Motor Frame Size
	74	19.12	115	0.86	2800	C 0 3 2 1 1 8 . _ M _ _ _ 1 - 1 A _ _	24.5	90S
68	20.61	123	0.82	2800	2 0 .			
64	22.11	117	0.8	2800	2 2 .			
86	16.36	91	1.57	5275	C 0 4 2 1 1 6 . 0 _ M _ _ _ 1 - 1 A _ _	26.5	90S	
74	19.12	117	1.43	5275	C 0 4 2 1 1 8 . 0			
68	20.61	125	1.36	5275	C 0 4 2 1 2 0 . 0			
64	22.11	121	1.28	5275	C 0 4 2 1 2 2 . 0			

The service factor (Fm) is only 0.82, therefore this unit is not acceptable and a larger C0421 unit must be selected with a service factor (Fm) of 1.36

5 CHECK OVERHUNG LOADS

If sprocket, gear, etc is mounted on the outputshaft then refer to Overhung Loads Procedure, and compare with allowable overhung load (N) of selected unit

Allowable overhung load (N) must be equal or more than calculated overhung load (P)

1.1 kW 4 POLE	N2 R/MIN	i	M2 Nm	Fm	N	UNIT DESIGNATION	Kg	
	Output Speed	Ratio	Output Torque	Service Factor	Overhung Load	Column Entry <input type="text" value="1"/> Through <input type="text" value="20"/> Spaces to be filled when entering order	Weight of Base Mount Unit	Motor Frame Size
	164	8.59	54	2.51	5286	C 0 4 2 1 8 . 0 _ M _ _ _ 1 - 1 A _ _	24.5	90S
121	11.61	72	2.04	5279	1 1 .			
107	13.20	82	1.87	5280	1 2 .			
94	14.95	92	1.71	5275	1 4 .			
86	16.36	91	1.57	5275	1 6 .			
74	19.12	117	1.43	5275	1 8 .			
68	20.61	125	1.36	5275	2 0 .			
64	22.11	121	1.28	5275	2 2 .			

NOTE: If any of the following conditions occur then consult our Application Engineers:-

a) Inertia of the Driven Machine (Referred to motor speed) >10
Inertia of Gear Unit plus the Motor

b) Ambient temperature is above 40°C

SERIES C

OUTPUT OPTIONS

OUTPUTSHAFT OPTIONS, COLUMN 11 ENTRY

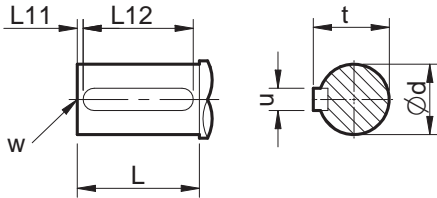

* Inch shafts have open ended keyways, therefore no 'L11' dimension is required

Column 11 Entry

Standard Single Extension C on Left E on Right

Standard Double Extension D

Std Heavy Duty Single Extension (Size C06) J

Std Heavy Duty Double Extension (Size C06) K

Inch Single Extension N on Left B on Right

Inch Double Extension P

Inch Heavy Duty Single Extension (Size C06) L

Size	Type of Output Shaft	Column 11 Entry	Dimensions in mm (Inch shaft in inches)						
			ød	L	L11	L12	t	u	w
C03	Metric - Standard	C, E, D	20.015 / 20.002	35	3	31.2	2.5	6	M6 x 1.0 x 16
	Inch	N, B, P	0.7500" / 0.7495"	1.38"	*	1.28"	0.83"	0.19"	1/4 UNF x 0.63"
C04	Metric - Standard	C, E, D	25.015 / 25.002	46	3	42	28	8	M10 x 1.5 x 22
	Inch	N, B, P	1.0000" / 0.9995"	1.81"	*	1.69"	1.10"	0.25"	1/4 UNF x 0.63"
C05	Metric - Standard	C, E, D	30.015 / 30.002	60	3	53	33	8	M10 x 1.5 x 22
	Inch	N, B, P	1.2500" / 1.2494"	2.36"	*	2.125"	1.36"	0.25"	3/8 UNF x 0.87"
C06	Metric - Standard	C, E, D	35.018 / 35.002	63	3	55	38	10	M12 x 1.75 x 22
	Metric - Heavy Duty	J, K	45.018 / 45.002	98	5	80	48.5	14	M16 x 2.0 x 36
	Inch	N, B, P	1.3750" / 1.3744"	2.48"	*	2.34"	1.51"	0.313"	1/2 UNF x 1.125"
	Inch - Heavy Duty	L	1.7500" / 1.7494"	3.86"	*	3.75"	1.92"	0.375"	5/8 UNF x 1.44"
C07	Metric - Standard	C, E, D	45.018 / 45.002	76	3	70	48.5	14	M16 x 2.0 x 36
	Inch	N, B, P	1.7500" / 1.7494"	2.99"	*	2.625"	1.917"	0.375"	5/8 UNF x 1.44"
C08	Metric - Standard	C, E, D	60.030 / 60.011	120	3	110	64	18	M20 x 2.5 x 42
	Inch	N, B	2.3750" / 2.3744"	4.72"	*	4.125"	2.646"	0.625"	3/4 UNF x 1.75"
	Inch - Double Ext	P	2.3125" / 2.3115"	4.72"	*	4.125"	2.582"	0.625"	3/4 UNF x 1.75"
C09	Metric - Standard	C, E, D	70.030 / 70.011	135	3	125	74.5	20	M20 x 2.5 x 42
	Inch	N, B	2.8750" / 2.8740"	5.12"	*	4.5"	3.20"	0.75"	3/4 UNF x 1.75"
	Inch - Double Ext	P	2.6875" / 2.6865"	5.12"	*	4.5"	2.963"	0.625"	3/4 UNF x 1.75"
C10	Metric - Standard	C, E, D	90.035 / 90.013	170	3	160	95	25	M24 x 3.0 x 50
	Inch	N, B	3.6250" / 3.6240"	6.69"	*	5.875"	4.009"	0.875"	1 UNF x 2.25"
	Inch - Double Ext	P	3.1875" / 3.1865"	6.69"	*	5.875"	3.518"	0.750"	1 UNF x 2.25"

SERIES C

OUTPUTBORE OPTIONS

OUTPUT BORE OPTIONS, COLUMN 11 ENTRY

Column 11 Entry

Metric Hollow Shaft



Inch Hollow Shaft



Metric Hollow Shaft with
reduced bore diameter

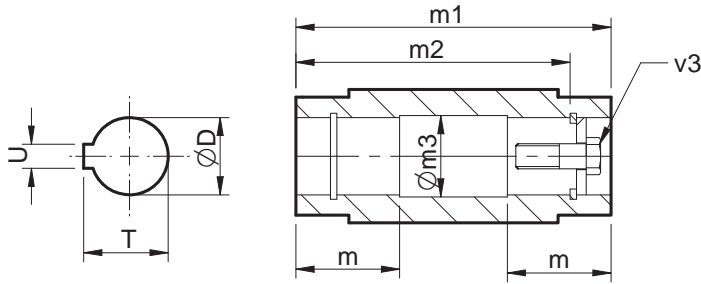

Size	Type of Bore	Column 11 Entry	Dimensions in mm (Inch shaft in inches)							
			ØD	m	m1	m2	Øm3	T	U	v3
C03	Standard	H	20.021/20.000	52	124	104	20.2	22.9	6	M6 x 1.0 x 40
	Inch	A	0.7508"/0.7500"	2.05"	4.88"	4.13"	0.76"	0.84"	0.188"	1/4" UNF x 1 1/2"
C04	Standard	H	30.021/30.000	54	130	122	30.2	33.5	8	M10 x 1.5 x 50
	Reduced Dia	Z	25.021/25.000	54	130	125	25.2	28.5	8	M10 x 1.5 x 50
	Inch	A	1.2510"/1.2500"	2.13"	5.12"	4.81"	1.26"	1.37"	0.25"	3/8 UNF x 2"
C05	Standard	H	35.025/35.000	56	140	127	35.3	38.5	10	M12 x 1.75 x 55
	Reduced Dia	Z	30.021/30.000	56	140	127	30.3	33.5	8	M10 x 1.5 x 45
	Inch	A	1.3760"/1.3750"	2.20"	5.52"	5.00"	1.39"	1.53"	0.313"	1/2" UNF x 2"
C06	Standard	H	45.025/45.000	70	180	156	45.3	49	14	M16 x 2.0 x 70
	Reduced Dia	Z	40.025/40.000	70	180	156	40.3	43.5	12	M16 x 2.0 x 70
	Inch	A	1.5010"/1.5000"	2.76"	7.08"	6.14"	1.51"	1.67"	0.375"	5/8" UNF x 2 3/4"
C07	Standard	H	60.030/60.000	79	218	188	60.5	64.6	18	M20 x 2.5 x 80
	Reduced Dia	Z	50.030/50.000	79	218	191	50.5	54	14	M16 x 2.0, x 70
	Inch	A	2.0010"/2.0000"	3.11"	8.58"	7.41"	2.02"	2.23"	0.50"	5/8" UNF x 3"
C08	Standard	H	70.030/70.000	90	250	220	70.5	75.1	20	M20 x 2.5 x 80
	Reduced Dia	Z	60.030/60.000	90	250	220	60.5	64.6	18	M20 x 2.5 x 80
	Inch	A	2.3760"/2.3750"	3.54"	9.84"	8.68"	2.40"	2.66"	0.625"	3/4" UNF x 3"
C09	Standard	H	90.035/90.000	107.5	300	265	90.5	95.6	25	M24 x 3.0 x 110
	Reduced Dia	Z	70.030/70.000	107.5	300	270	70.5	75.1	20	M20 x 2.5, x100
	Inch	A	2.7510"/2.7500"	4.23"	11.82"	10.65"	2.76"	3.04"	0.625"	3/4" UNF x 4 1/4"
C10	Standard	H	100.035/100.000	132.5	350	313	100.5	106.6	28	M24 x 3.0 x 110
	Reduced Dia	Z	80.030/80.000	132.5	350	313	80.5	85.6	22	M20 x 2.5 x 100
	Inch	A	3.2510"/3.2500"	5.22"	13.78"	12.32"	3.26"	3.59"	0.75"	1" UNF x 4 1/4"

SERIES C MOTOR ADAPTERS IEC AND NEMA

Double Reduction Units

Compact Motor - Column 12 Entry - D

Power	C0321		C0421		C0521		C0621		C0721		C0821	
	8.0 - 28. 36. - 40.	32. 45. - 250	8.0 - 28. 36. - 40.	32. 45. - 250	8.0 - 40. 56. - 63.	45. - 50. 71. - 250	8.0 - 28. 36. - 40.	32. 45. - 250	8.0 - 28. 36. - 40.	32. 45. - 250	8.0 - 40. 56. - 63.	45. - 50. 71. - 250
0.25 kW	•	•	•	•	•	•	•	•	•	•	•	•
0.37 kW	•	•	•	•	•	•	•	•	•	•	•	•
0.55 kW	•	•	•	•	•	•	•	•	•	•	•	•
0.75 kW	•	•	•	•	•	•	•	•	•	•	•	•
1.1 kW	•	•	•	•	•	•	•	•	•	•	•	•
1.5 kW	•	•	•	•	•	•	•	•	•	•	•	•
2.2 kW	•	•	•	•	•	•	•	•	•	•	•	•
3.0 kW	•	•	•	•	•	•	•	•	•	•	•	•
4.0 kW	•	•	•	•	•	•	•	•	•	•	•	•
5.5 kW	•	•	•	•	•	•	•	•	•	•	•	•
7.5 kW	•	•	•	•	•	•	•	•	•	•	•	•

Standard Motor IEC Flanges B14 - Column 12 Entry

Motor	C0321		C0421		C0521		C0621		C0721	
	8.0 - 28. 36. - 40.	32. 45. - 250	8.0 - 28. 36. - 40.	32. 45. - 250	8.0 - 40. 56. - 63.	45. - 50. 71. - 250	8.0 - 28. 36. - 40.	32. 45. - 250	8.0 - 28. 36. - 40.	32. 45. - 250
71	H	H	H	H	-	H	-	-	-	-
80	B	K	B	K	B	K	-	G	-	G
90	D	R	D	R	D	R	Z	J	-	J
100	F	S	F	S	F	S	B	L	B	L
112	F	S	F	S	F	S	B	L	B	L
132	-	-	-	-	-	-	-	-	D	N

Standard Motor IEC Flanges B5 - Column 12 Entry

Motor	C0321		C0421		C0521		C0621		C0721		C0821		C0921		C1021	
	8.0 - 28. 36. - 40.	32. 45. - 250	8.0 - 28. 36. - 40.	32. 45. - 250	8.0 - 40. 56. - 63.	45. - 50. 71. - 250	8.0 - 28. 36. - 40.	32. 45. - 250	8.0 - 28. 36. - 40.	32. 45. - 250	8.0 - 40. 56. - 63.	45. - 50. 71. - 250	8.0 - 40. 56. - 63.	45. - 50. 71. - 250	8.0 - 40. 56. - 63.	45. - 50. 71. - 250
63	F	F	F	F	-	F	-	V	-	-	-	-	-	-	-	-
71	G	G	G	G	-	G	-	D	-	-	-	-	-	-	-	-
80	A	J	A	J	A	J	W	F	-	F	-	D	-	F	-	-
90	C	Q	C	Q	C	Q	Y	H	-	H	-	F	-	F	-	-
100	-	-	-	-	-	-	A	K	A	K	A	F	-	G	-	F
112	-	-	-	-	-	-	A	K	A	K	A	F	-	G	-	F
132	-	-	-	-	-	-	N	P	C	M	B	G	-	H	-	F
160	-	-	-	-	-	-	-	-	E	P	C	H	A	J	A	G
180	-	-	-	-	-	-	-	-	-	-	-	-	B	K	B	H
200	-	-	-	-	-	-	-	-	-	-	-	-	C	L	C	J
225	-	-	-	-	-	-	-	-	-	-	-	-	D	M	D	K

NEMA Motor C Face - Column 12 Entry

Motor	C0321		C0421		C0521		C0621		C0721		C0821		C0921		C1021	
	8.0 - 28. 36. - 40.	32. 45. - 250	8.0 - 28. 36. - 40.	32. 45. - 250	8.0 - 40. 56. - 63.	45. - 50. 71. - 250	8.0 - 28. 36. - 40.	32. 45. - 250	8.0 - 28. 36. - 40.	32. 45. - 250	8.0 - 40. 56. - 63.	45. - 50. 71. - 250	8.0 - 40. 56. - 63.	45. - 50. 71. - 250	8.0 - 40. 56. - 63.	45. - 50. 71. - 250
56c	T	U	T	U	T	U	-	Q	-	Q	M	-	-	-	-	-
143/145TC	V	W	V	W	V	W	-	R	-	R	N	-	-	-	-	-
182/184TC	X	-	X	-	X	-	S	T	S	T	J	P	-	S	-	P
213/215TC	-	-	-	-	-	-	U	-	U	V	K	Q	-	T	-	Q
254/256TC	-	-	-	-	-	-	-	-	W	-	L	U	P	U	L	R
284/286TC	-	-	-	-	-	-	-	-	-	-	-	-	Q	V	M	S
324/326TC	-	-	-	-	-	-	-	-	-	-	-	-	R	W	N	T

SERIES C MOTOR ADAPTERS IEC AND NEMA

Triple Reduction Units

Compact Motor - Column 12 Entry - D

Power	C0331		C0431		C0531		C0631		C0731	
	132 - 150	100 - 118 160 - 900	132 - 150	100 - 118 160 - 900	132 - 150	100 - 118 160 - 900	100 - 150 200 - 225	160 - 180 265 - 900	132 - 150	100 - 118 160 - 900
0.25 kW	•	•	•	•	•	•	-	•	-	-
0.37 kW	•	•	•	•	•	•	-	•	-	-
0.55 kW	•	•	•	•	•	•	•	•	-	•
0.75 kW	•	•	•	•	•	•	•	•	-	•
1.1 kW	•	-	•	-	•	-	•	-	•	•
1.5 kW	•	-	•	-	•	-	•	-	•	•
2.2 kW	-	-	-	-	-	-	-	-	•	•
3.0 kW	-	-	-	-	-	-	-	-	•	•
4.0 kW	-	-	-	-	-	-	-	-	•	-
5.5 kW	-	-	-	-	-	-	-	-	•	-
7.5 kW	-	-	-	-	-	-	-	-	-	-

Standard Motor IEC Flanges B14 - Column 12 Entry

Motor	C0331		C0431		C0531		C0631		C0731	
	132 - 150	100 - 118 160 - 900	132 - 150	100 - 118 160 - 900	132 - 150	100 - 118 160 - 900	100 - 150 200 - 225	160 - 180 265 - 900	132 - 150	100 - 118 160 - 900
71	H	H	H	H	H	H	-	H	-	-
80	B	K	B	K	B	K	B	K	-	G
90	D	R	D	R	D	R	D	R	Z	J
100	E	S	E	S	E	S	E	S	B	L
112	-	-	-	-	-	-	-	-	B	L

Standard Motor IEC Flanges B5 - Column 12 Entry

Motor	C0331		C0431		C0531		C0631		C0731	
	132 - 150	100 - 118 160 - 900	132 - 150	100 - 118 160 - 900	132 - 150	100 - 118 160 - 900	100 - 150 200 - 225	160 - 180 265 - 900	132 - 150	100 - 118 160 - 900
63	F	F	F	F	F	F	-	F	-	V
71	G	G	G	G	G	G	-	G	-	D
80	A	J	A	J	A	J	A	J	W	F
90	C	Q	C	Q	C	Q	C	Q	Y	H
100	-	-	-	-	-	-	-	-	A	K
112	-	-	-	-	-	-	-	-	A	K
132	-	-	-	-	-	-	-	-	N	P

NEMA Motor C Face - Column 12 Entry

Motor	C0331		C0431		C0531		C0631		C0731	
	132 - 150	100 - 118 160 - 900	132 - 150	100 - 118 160 - 900	132 - 150	100 - 118 160 - 900	100 - 150 200 - 225	160 - 180 265 - 900	132 - 150	100 - 118 160 - 900
56c	T	U	T	U	T	U	T	U	-	Q
143/145TC	V	W	V	W	V	W	V	W	-	R
182/184TC	X	-	X	-	X	-	X	-	S	T
213/215TC	-	-	-	-	-	-	-	-	U	-

SERIES C

MOTOR ADAPTERS

IEC AND NEMA

Quadruple Reduction Units

Compact Motor - Column 12 Entry - D

Power	C0341	C0441	C0541	C0641	C0741	C0841		C0941		C1041	
	All Ratios	All Ratios	All Ratios	All Ratios	All Ratios	500	560 +	500	560 +	450	560 +
0.25 kW	•	•	•	•	•	-	-	-	-	-	-
0.37 kW	•	•	•	•	•	-	-	-	-	-	-
0.55 kW	•	•	•	•	•	-	•	-	•	-	-
0.75 kW	•	•	•	•	•	-	-	-	•	-	-
1.1 kW	-	-	-	-	-	•	•	•	•	-	•
1.5 kW	-	-	-	-	-	•	•	•	•	-	•
2.2 kW	-	-	-	-	-	•	•	•	•	-	•
3.0 kW	-	-	-	-	-	•	•	•	•	-	•
4.0 kW	-	-	-	-	-	•	-	•	-	-	•
5.5 kW	-	-	-	-	-	•	-	•	-	-	•
7.5 kW	-	-	-	-	-	-	-	-	-	-	•

Standard Motor IEC Flanges B14 - Column 12 Entry

Motor	C0341	C0441	C0541	C0641	C0741	C0841		C0941		C1041	
	All Ratios	All Ratios	All Ratios	All Ratios	All Ratios	500	560 +	500	560 +	450	560 +
71	H	H	H	H	H	-	-	-	-	-	-
80	K	K	K	K	K	-	G	-	G	-	G
90	R	R	R	R	R	Z	J	Z	J	-	J
100	S	S	S	S	S	B	L	B	L	B	L
112	-	-	-	-	-	B	L	B	L	B	L
132	-	-	-	-	-	-	-	-	-	D	N

Standard Motor IEC Flanges B5 - Column 12 Entry

Motor	C0341	C0441	C0541	C0641	C0741	C0841		C0941		C1041	
	All Ratios	All Ratios	All Ratios	All Ratios	All Ratios	500	560 +	500	560 +	450	560+
63	F	F	F	F	F	-	V	-	V	-	-
71	G	G	G	G	G	-	D	-	D	-	-
80	J	J	J	J	J	W	F	W	F	-	F
90	Q	Q	Q	Q	Q	Y	H	Y	H	-	H
100	-	-	-	-	-	A	K	A	K	A	K
112	-	-	-	-	-	A	K	A	K	K	K
132	-	-	-	-	-	N	P	N	P	C	M
160	-	-	-	-	-	-	-	-	-	E	-

NEMA Motor C Face - Column 12 Entry

Motor	C0341	C0441	C0541	C0641	C0741	C0841		C0941		C1041	
	All Ratios	All Ratios	All Ratios	All Ratios	All Ratios	500	560 +	500	560 +	450	560 +
56c	U	U	U	U	U	-	Q	-	Q	-	Q
143/145TC	W	W	W	W	W	-	R	-	R	-	R
182/184TC	-	-	-	-	-	S	T	S	T	S	T
213/215TC	-	-	-	-	-	U	-	U	-	U	V

SERIES C

LUBRICATION

Lubricant and Quantity

Unit sizes C03, 04, 05 and 06 are factory filled with a grade 6G lubricant.

Unit sizes C07, 08, 09 and 10 will be despatched without oil.

The oil grade is stamped on the name plate and the oil level should be established by filling until the oil escapes via the level plug,

The grade and level are determined from the operating speed of the gear unit and the ambient temperature range, which if not given when ordering will be assumed to be 1450 rev / min input and ambient temperature range 0 to 35°C. Oil grades and oil level should always be checked before installation, Consult the Installation and Maintenance instructions provided with the gear unit.

To determine the oil grade refer to table 1, and then refer to the Installation and Maintenance instructions to select an approved lubricant

To determine the oil capacity refer to appropriate table 2 or 3. Oil capacities are only approximate and units should be filled until oil escapes from the level plug holes. Do not overfill as excess will cause overheating and leakage.

Always fill with correct lubricant as marked on the nameplate. Never mix lubricant grades.

See Installation and Maintenance instructions for for lists of approved lubricants within the grades.

 If not stated with the order these are the operating conditions that will be assumed

Table 1 Series C oil grades

Gear unit details			Ambient temperature range		
Type	Gear unit details	Input Speed (Rev/min)	-30°C - 20°C	0°C - 35°C	20°C - 50°C
Doubles	Ratio 8 - 18	0 - 750	6G	6G	8G
		0>750 - 2000	5G	6G	7G
		>2000 - 3000	4G	6G	6G
	20 - 36	0 - 2000	6G	6G	8G
		>2000 - 3000	5G	6G	7G
		40 - 250	0 - 3000	6G	6G
Quadruples	< - 2800	0 - 750	6G	7G	9G
		>750 - 3000	6G	6G	8G
	3200 - 16000	0 - 3000	6G	7G	9G

* For other ambient temperatures please refer to our Application Engineers.

Table 2 lubricant quantity (Litres) (double reduction and final stage quadruple reduction)

Double, Triple & Final stage Quadruple Reduction															
Size		C0321	C0331	C0421	C0431	C0521	C0531	C0621	C0631	C0721	C0731	C0821	C0921	C1021	
Mounting position	1	Level 1 *	0.3	0.4	0.4	0.5	0.7	0.9	1.5	2.1	4.5	4.8	7.1	17	28
		Level 2 *									3.0	3.8	5.9	11	17
	2		0.5	0.8	0.7	0.9	1.0	1.4	2.3	2.5	3.5	3.7	6.2	12	21
			0.5	0.8	0.7	0.9	1.0	1.4	2.2	2.5	3.5	3.7	6.2	12	21
	4	Level 1 *	0.7	1.2	1.0	1.5	1.4	2.1	3.1	4.0	5.1	5.9	9.5	17	26
		Level 2 *									3.0	3.6	4.8	8.3	14
	5		0.6	1.0	0.9	1.3	1.4	2.0	3.0	4.6	5.6	6.6	9.6	18	31
			0.7	1.2	1.0	1.5	1.4	1.9	3.2	4.0	7.4	9.2	12	25	42
	6	Level 1 *	0.7	1.2	1.0	1.5	1.4	1.9	3.2	4.0	5.1	6.9	9.5	17	28
		Level 2 *													

* Use Level 1 for output speeds lower than 100 rpm * Use Level 2 for output speeds of 100 rpm and higher.

Table 3 lubricant quantity (Litres) (primary stage quadruple reduction)

Primary stage quadruple reduction									
Size	C0341	C0441	C0541	C0641	C0741	C0841	C0941	C1041	
Secondary unit (Lubricant quantity see table 2)	C0321	C0421	C0521	C0621	C0721	C0821	C0921	C1021	
Primary unit	M0122	M0122	M0122	M0322	M0322	M0522	M0522	M0722	
Primary Quantity (unit lubricant)	1 to 4	0.5	0.5	0.5	0.8	0.8	1.5	1.5	2.6
	5 & 6	1.0	1.0	1.0	1.4	1.4	2.6	2.6	4.7

• Unit filled with Grade 6E lubricant suitable for all ambient temperatures between 0°C to 35°C and are 'lubricated for life'

SERIES C

MOUNTING POSITIONS

Column 13 Entry

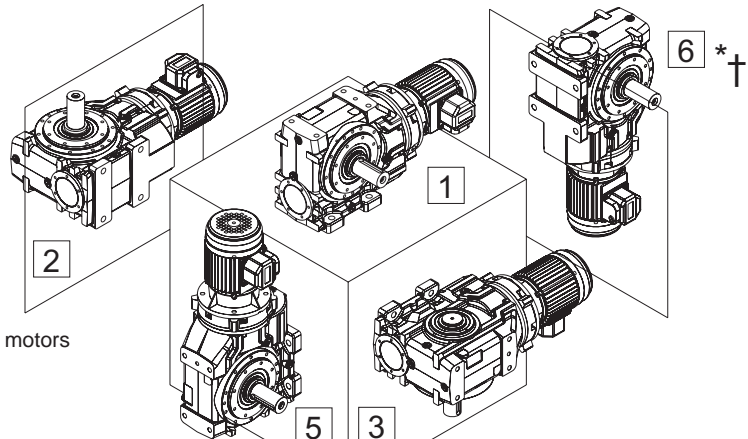

Base Mounted Units

* Mounting Position 6 is not recommended for geared motors
- Consult Application Engineering

† Gear Units for use in mounting positions 5 and 6 should only be selected with overall ratios greater or equal to those shown in table below

Size	Input speed (RPM)			
	1000	1500	1800	>1800
C03-C08	All	All	All	Consult application engineering
C09	18:1	18:1	25:1	
C10	18:1	40:1	63:1	

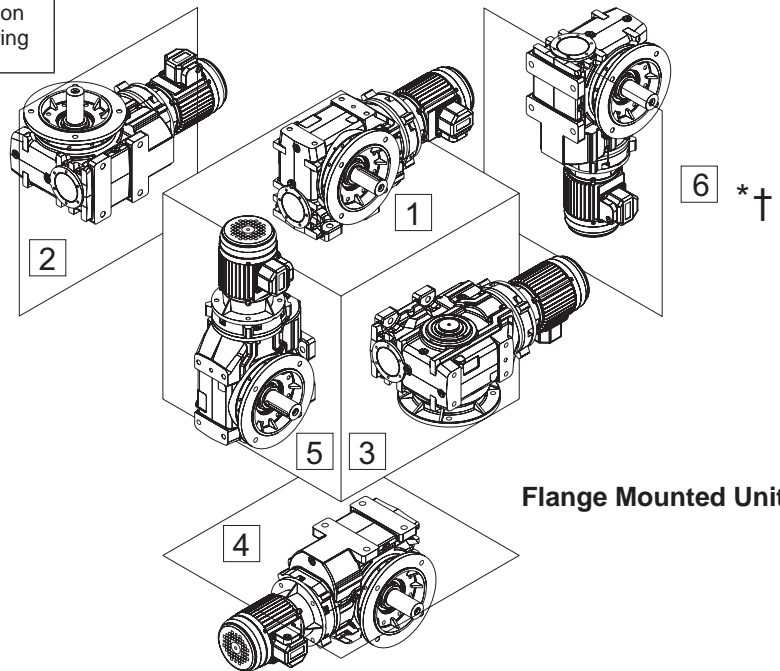

Flange Mounted Units

Mounting Positions- Shown as Motorised - Applies also for Reducers

COLUMN 14 ENTRY

All motors

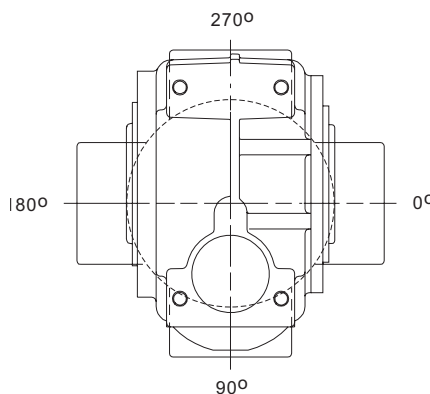

Column 14 entry	Terminal box position
A	0°
B	90°
C	180°
D	270°
-	Reducer or no motor fitted

SERIES C

UNIT HANDINGS

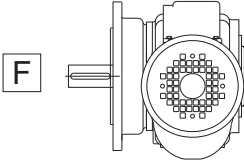
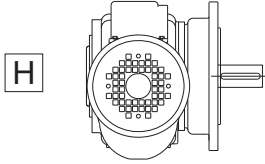
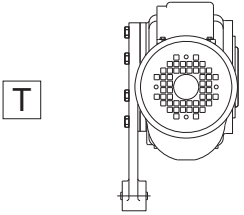
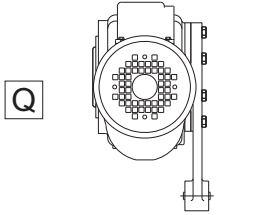
Column 9 entry	Left	Right
Std unit with foutput flange		
Std unit with Torque bracket		

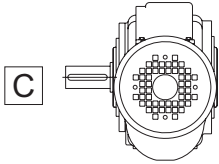
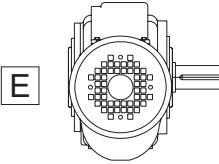
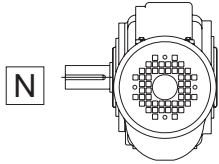
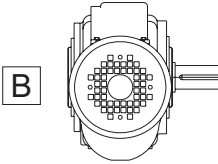
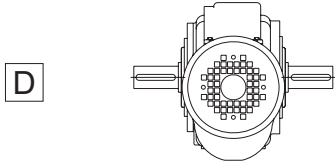
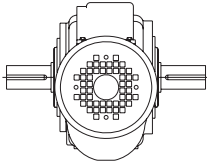
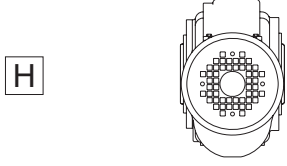
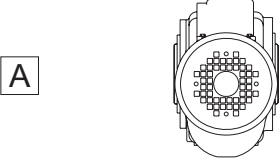
Column entry 11	Metric		Inch	
	Left	Right	Left	Right
Single output shaft				
Double output shaft				
Hollow shaft				

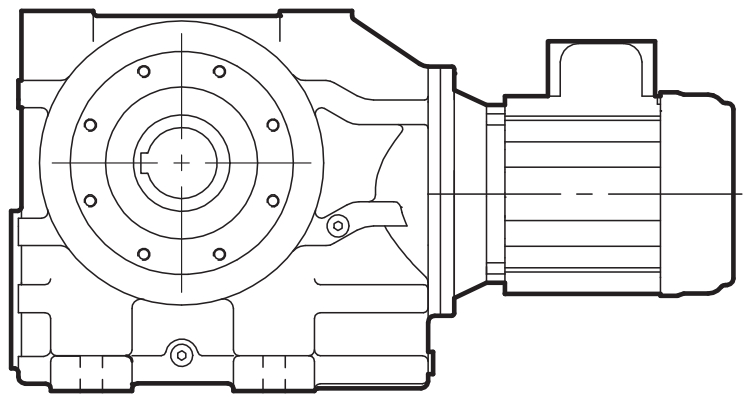
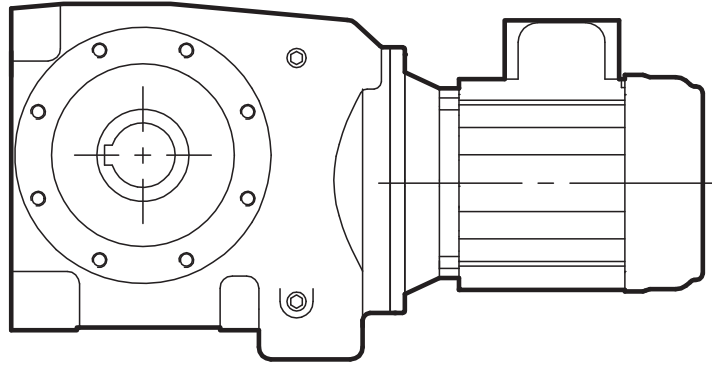

MOTORISED
SERIES C

SERIES C

MOTOR PERFORMANCE DATA

TEFC Squirrel Cage 3 Phase Motors
4 poles = 1500 rpm 400V, 50Hz, S1
IP55, Class F
IE2 Efficiency Class

P (kW)	Frame Size	n RPM	I (A)	Ist / I	Tst / T	J (kgm ²)
0.12	63	1360	0.6	2.6	2.5	0.0004
0.18	63	1370	0.72	3.0	2.2	0.0005
0.25	71	1370	0.65	3.5	2.0	0.0007
0.37	71	1380	0.88	4.0	2.1	0.0009
0.55	80	1420	1.45	5.0	2.0	0.0015
0.75	80	1420	1.8	5.3	2.7	0.0020
1.1	90S	1430	2.4	6.2	2.7	0.0045
1.5	90L	1430	3.3	6.3	2.7	0.0053
2.2	100L	1450	4.7	6.4	2.9	0.0085
3.0	100L	1450	6.3	7.7	2.9	0.0110
4.0	112M	1450	8.2	7.0	2.9	0.0125
5.5	132S	1450	11.1	5.9	2.0	0.033
7.5	132M	1450	14.8	5.6	2.0	0.036
11	160M	1460	21	6.7	2.2	0.081
15	160L	1460	28.5	7.1	2.6	0.099
18.5	180M	1470	35	7.2	2.6	0.166
22	180L	1470	41	7.3	2.6	0.195
30	200L	1470	56	6.7	2.2	0.31
37	225S	1470	68	7.1	2.6	0.36
45	225M	1480	83	7.5	2.7	0.44
55	250M	1480	98	7.5	2.6	0.77
75	280S	1480	134	6.8	2.5	1.25
90.0	280M	1480	160	7.1	2.5	1.50
110	315S	1480	195	7.7	2.4	2.30
132	315M	1480	232	7.2	2.4	2.60
160	315L	1480	284	7.2	2.4	2.90

TEFC Squirrel Cage 3 Phase Motors
6 poles = 1000 rpm 400V, 50Hz, S1
IP55, Class F
IE2 Efficiency Class

P (kW)	Frame Size	n RPM	I (A)	Ist / I	Tst / T	J (kgm ²)
0.12	63	900	0.57	2.1	2.1	0.0007
0.18	71	900	0.6	3.1	2	0.0009
0.25	71	920	0.77	3.4	2.1	0.0011
0.37	80	920	1.09	3.6	2.2	0.0019
0.55	80	920	1.51	3.8	1.8	0.0024
0.75	90S	930	2.36	4.5	1.8	0.005
1.1	90L	930	3	4	2.3	0.006
1.5	100L	940	3.8	4	1.9	0.009
2.2	112M	940	5.5	4.5	1.7	0.125
3	132S	960	8	5.5	1.8	0.033
4	132M	960	10	4.6	1.7	0.038
5.5	132M	960	12.9	5.1	2	0.045
7.5	160M	970	15.4	7.4	1.7	0.087
11	160L	970	23	7.5	1.9	0.114
15	180L	970	31	6.5	1.8	0.192
18.5	200L	980	36	6.7	2.2	0.380
22	200L	980	43	6.6	2.2	0.440
30	225M	985	56	7	2.6	0.660
37	250M	985	69	6.8	2.7	1.16
45	280S	985	85	7	2.5	1.85
55	280M	985	100	7	2.7	2.20
75	315S	985	139	7.4	2.4	3.20
90	315M	985	163	7.5	2.4	4.10
110	315L	985	201	7.4	2.5	4.90
132	315L	985	240	7.5	2.7	5.60

Key

I = Nominal current Ist/I = Starting current factor Tst/T = Starting torque factor J = Motor moment of inertia
P = Rated output power n = Motor speed T = Rated output torque

Recalculation Factors Fv

Recalculation factors for current at rated voltages other than 400V, 50 Hz.

50 Hz	Fv
220V	1.82
230V	1.74
415V	0.96
500V	0.80
660V	0.61
690V	0.58

60 Hz Operation

Motors wound for a certain voltage at 50 Hz can be operated at 60 Hz, without any modifications, subject to the following changes in their data

60 Hz	P (kW)	n RPM	I (A)	Ist (I)	T (Nm)	Tst (T)
380V	100%	120%	100%	80%	83%	66%
400V	100%	120%	98%	83%	83%	70%
415V	105%	120%	100%	8%8	86%	78%
440V	110%	120%	100%	95%	91%	85%
460V	115%	120%	100%	100%	96%	95%
480V	120%	120%	100%	105%	100%	100%

SERIES C

MOTOR DETAILS

B14 'C' face

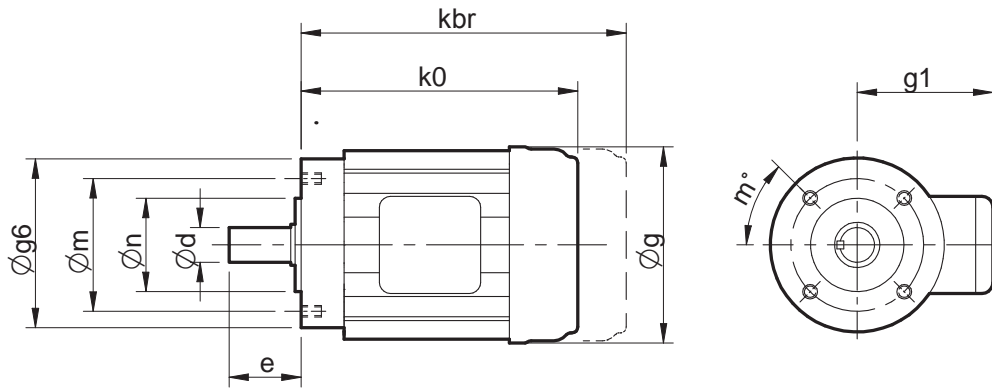

Size	$\varnothing g6$	$\varnothing m$	$\varnothing n$	$\varnothing d$	e	ko	kbr	$\varnothing g$	g1	m	$\varnothing s$
71	105	85	70	14	30	220	270	140	105	45 deg	4xM6
80	120	100	80	19	40	240	290	158	122	45 deg	4xM6
90S	140	115	95	24	50	260	310	180	129	45 deg	4xM8
90L	140	115	95	24	50	280	330	180	129	45 deg	4xM8
100L	160	130	110	28	60	310	375	198	152	45 deg	4xM8
112M	160	130	110	28	60	330	405	222	165	45 deg	4xM8
132S	200	165	130	38	80	380	475	260	185	45 deg	4xM10
132M	200	165	130	38	80	420	505	260	185	45 deg	4xM10

B5 'D' face

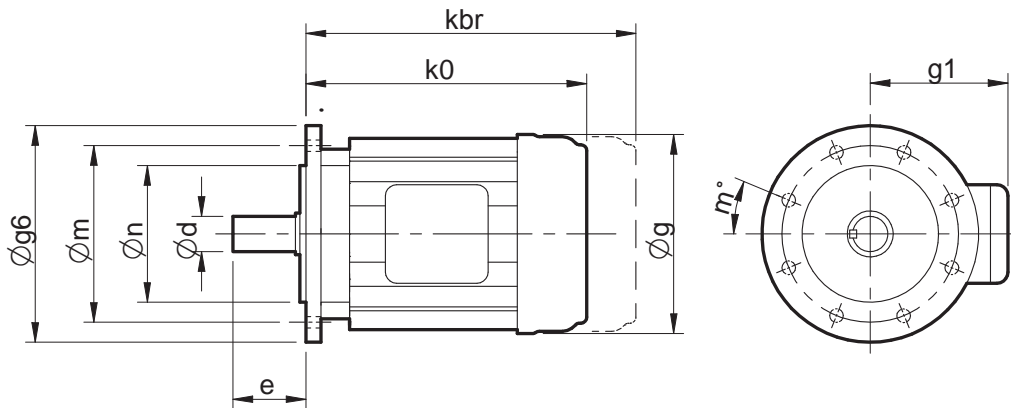

Size	$\varnothing g6$	$\varnothing m$	$\varnothing n$	$\varnothing d$	e	ko	kbr	$\varnothing g$	g1	m	$\varnothing s$
63	140	115	95	11	23	195	260	125	100	45 deg	4xM8
71	160	130	110	14	30	220	270	140	105	45 deg	4xM8
80	200	165	130	19	40	240	290	158	122	45 deg	4xM10
90S	200	165	130	24	50	260	310	180	129	45 deg	4xM10
90L	200	165	130	24	50	280	330	180	129	45 deg	4xM10
100L	250	215	180	28	60	310	375	198	152	45 deg	4xM12
112M	250	215	180	28	60	330	405	222	165	45 deg	4xM12
132S	300	265	230	38	80	380	475	260	185	45 deg	4xM12
132M	300	265	230	38	80	420	505	260	185	45 deg	4xM12
160M	350	300	250	42	110	480	565	320	264	45 deg	4xM16
160L	350	300	250	42	110	530	615	320	264	45 deg	4xM16
180M	350	300	250	48	110	560	-	360	279	45 deg	4xM16
180L	350	300	250	48	110	595	-	360	279	45 deg	4xM16
200L	400	350	300	55	110	660	-	400	317	45 deg	4xM16
225S	450	400	350	60	140	680	-	450	385	22.5 deg	8xM16
225M	450	400	350	60	140	715	-	450	385	22.5 deg	8xM16
250M	550	500	450	65	140	770	-	500	405	22.5 deg	8xM16
280S	550	500	450	75	140	850	-	560	480	22.5 deg	8xM16
280M	550	500	450	75	140	930	-	560	480	22.5 deg	8xM16
315S	660	600	550	80	170	1100	-	630	530	22.5 deg	8xM20
315M	660	600	550	80	170	1260	-	630	530	22.5 deg	8xM20
315L	660	600	550	80	170	1400	-	630	530	22.5 deg	8xM20

ADDITIONAL MOTOR FEATURES

Additional Motor Features- Column 19 Entry

Column 19 Entry	Brake Motor	Hand Release on Brake	Forced Ventilation/ Constant Blower (TECB)	Thermistors	Special
-					
A	•				
B	•	•			
C			•		
D	•		•		
E	•	•	•		
F				•	
G	•			•	
H	•	•		•	
K			•	•	
L	•		•	•	
M	•	•	•	•	
S					•

Please refer to Application Engineering for details of the following additional motor features

- PGF encoder flange
- Wash down
- Customised brake torque
- Separate brake supply
- Aluminium fan
- Anti Condensation heater
- Bi-metal temperature detectors, Thermostat
- EExEII T3
- Ex nA II T3
- IP56
- IP65
- Metal fan cover
- Rain cowl
- Separate terminal box

SERIES C

ADDITIONAL GEARBOX FEATURES

Additional motor features- Column 20 entry

Colum 20 entry	Double Oil Seals on Output Shaft	Oil Level Glass C07- C10	* Motorised Backstop		Special
			CW Rotation	CCW Rotation	
-					
A	•				
B		•			
C	•	•			
D			•		
E	•		•		
F		•	•		
G	•	•	•		
H				•	
I	•			•	
J		•		•	
K	•	•		•	
L					•

Please refer to our Application Engineers for details of the following additional gearbox features

- Prime paint only
- Wash down
- BISSC compatible
- Special oil (food compatible, bio-degradable, different viscosities etc)

* IEC B5 frame sizes 100 - 200 and NEMA frame sizes 182TC -326TC

SERIES C SELECTION TABLE GEARED MOTORS

0.12 kW

4 POLE

N2 RPM	i	M2 Nm	Fm	N	Unit Designation	kg	
Output Speed	Ratio	Output Torque	Service Factor	Overhung Load	Column Entry 1 - 20 Spaces to be filled when entering order	Weight of Base Mount unit	Motor Size
158	8.59	6	13.44	2860	C 0 3 2 1 8 . 0 _ M _ _ _ . 1 2 A - -	14.5	63
117	11.61	8	10.86	2860	1 1 .		
103	13.20	9	9.93	2860	1 2 .		
91	14.95	10	9.07	2860	1 4 .		
83	16.36	10	8.68	2860	1 6 .		
71	19.12	13	7.61	2860	1 8 .		
66	20.61	14	7.21	2860	2 0 .		
62	22.11	13	7.10	2860	2 2 .		
54	25.14	15	6.50	2860	2 5 .		
48	28.48	16	5.98	2860	2 8 .		
40	33.71	22	5.03	2850	3 2 .		
37	36.43	21	5.04	2850	3 6 .		
35	39.26	22	4.80	2850	4 0 .		
30	45.50	30	4.05	2850	4 5 .		
26	53.31	35	3.63	2840	5 0 .		
24	56.19	32	3.74	2850	5 6 .		
21	64.21	36	3.42	2840	6 3 .		
18	74.55	48	2.98	2840	7 1 .		
16	82.83	53	2.76	2830	8 0 .		
16	86.67	48	2.89	2840	9 0 .		
13	101.54	55	2.57	2830	1 0 0		
12	114.33	72	1.78	2820	1 1 2		
10	129.94	82	1.54	2820	1 2 5		
10	142.00	75	1.96	2820	1 4 0		
8.6	157.78	83	1.78	2820	1 6 0		
6.2	217.78	113	1.31	2800	2 1 2		
5.5	247.50	127	1.16	2800	2 5 0		
13.0	105.36	65	2.26	2830	C 0 3 3 1 1 0 0 _ M _ _ _ . 1 2 A - -	17.5	63
11	120.39	75	1.99	2820	1 1 8		
10	130.10	68	2.16	2830	1 3 2		
10	140.21	73	2.03	2820	1 5 0		
8.4	162.50	100	1.49	2810	1 6 0		
7.1	190.38	116	1.27	2800	1 8 0		
6.8	200.68	103	1.45	2810	2 0 0		
5.9	229.32	116	1.27	2800	2 2 5		
5.1	266.25	161	0.92	2780	2 6 5		
4.6	295.83	178	0.84	2770	2 8 0		
4.4	309.52	154	0.96	2780	3 1 5		
3.8	362.64	179	0.83	2770	3 6 0		
16	82.83	53	3.56	5290	C 0 4 2 1 8 0 . _ M _ _ _ . 1 2 A - -	16.5	63
12	114.33	72	1.78	5290	1 1 2		
10	129.94	83	1.54	5290	1 2 5		
10	142.00	77	3.25	5290	1 4 0		
8.6	157.78	85	3.01	5290	1 6 0		
6.2	217.78	115	1.78	5290	2 1 2		
5.5	247.50	130	1.54	5280	2 5 0		
13	105.36	67	3.04	5290	C 0 4 3 1 1 0 0 _ M _ _ _ . 1 2 A - -	20.5	63
11	120.39	76	2.66	5290	1 1 8		
10	130.10	70	3.40	5290	1 3 2		
10	140.21	75	3.25	5290	1 5 0		
8.4	162.50	102	1.97	5290	1 6 0		
7.1	190.38	118	1.69	5290	1 8 0		
6.8	200.68	105	2.61	5290	2 0 0		
5.9	229.32	120	2.31	5290	2 2 5		
5.1	266.25	164	1.20	5270	2 6 5		
4.6	295.83	181	1.09	5270	2 8 0		
4.4	309.52	159	1.74	5280	3 1 5		
3.8	362.64	185	1.50	5270	3 6 0		
2.7	507.14	254	1.09	5240	5 0 0		
5.7	240.00	131	3.67	7440	C 0 5 2 1 2 5 0 _ M _ _ _ . 1 2 A - -	18.5	63
8.5	160.26	103	3.82	7440	C 0 5 3 1 1 6 0 _ M _ _ _ . 1 2 A - -	21.5	63
7.2	187.76	120	3.27	7440	1 8 0		
5.9	229.81	125	3.85	7440	2 2 5		
5.2	262.58	165	2.34	7440	2 6 5		
4.7	291.75	183	2.11	7440	2 8 0		
4.4	310.18	165	2.91	7440	3 1 5		
3.7	363.40	192	2.50	7440	3 6 0		
3.4	402.70	251	1.53	7440	4 0 0		
3.0	457.66	285	1.34	7440	4 5 0		
2.7	508.21	264	1.82	7440	5 0 0		
2.4	564.68	292	1.65	7440	5 6 0		
1.7	779.42	397	1.21	7430	8 0 0		
1.5	885.79	450	1.07	7420	9 0 0		
4.5	299.67	200	3.83	11800	C 0 6 3 1 2 8 0 _ M _ _ _ . 1 2 A - -	37.5	63
3.8	357.32	200	3.83	11900	3 6 0		
3.4	395.39	262	2.92	11800	4 0 0		
3.0	449.50	296	2.59	11800	4 5 0		
2.6	514.75	281	2.72	11800	5 0 0		
2.3	580.00	315	2.43	11800	5 6 0		
1.8	765.28	410	1.87	11700	8 0 0		
1.6	870.00	462	1.66	11700	9 0 0		

NOTE:

Other output speeds are available using 2 & 8 pole motors. Please contact our Application Engineers

SERIES C SELECTION TABLE GEARED MOTORS

0.12 kW
4 POLE

N2 RPM	i	M2 Nm	Fm	N	Unit Designation	kg	
Output Speed	Ratio	Output Torque	Service Factor	Overhung Load	Column Entry 1 - 20 Spaces to be filled when entering order	Weight of Base Mount unit	Motor Size
1.3	1021.77	655	1.17	11402	C 0 6 4 1 1 0 C _ M _ _ _ _ . 1 2 A _ _	50.5	63
1.2	1110.85	711	1.08	11402	1 1 C		
1.0	1299.84	815	0.94	11402	1 2 C		
0.91	1495.14	937	0.82	11402	1 4 C		
2.7	499.88	321	3.95	29200	C 0 7 3 1 5 0 0 _ M _ _ _ _ . 1 2 A _ _	84.5	63
2.5	547.35	350	3.62	29200	5 6 0		
1.8	747.66	471	2.67	29200	8 0 0		
1.6	838.50	526	2.39	29200	9 0 0		
1.3	1009.20	679	1.97	28931	C 0 7 4 1 1 0 C _ M _ _ _ _ . 1 2 A _ _	88.5	63
1.2	1097.19	738	1.82	28931	1 1 C		
1.1	1213.28	806	1.66	28931	1 2 C		
0.97	1395.57	926	1.45	28931	1 4 C		
0.90	1517.24	1006	1.33	28931	1 6 C		
0.82	1661.54	1097	1.22	28931	1 8 C		
0.68	1994.66	1314	1.02	28931	2 0 C		
0.62	2185.71	1441	0.93	28931	2 2 C		
0.55	2462.77	1619	0.83	28931	2 5 C		
1.3	1083.79	737	3.86	41656	C 0 8 4 1 1 1 C _ M _ _ _ _ . 1 2 A _ _	141.5	63
1.1	1191.45	812	3.34	41656	1 2 C		
0.97	1404.96	954	2.84	41656	1 4 C		
0.89	1532.14	1030	3.18	41545	1 6 C		
0.72	1901.25	1276	2.57	41545	1 8 C		
0.65	2088.45	1396	2.40	41545	2 0 C		
0.61	2241.96	1501	2.18	41545	2 2 C		
0.55	2462.71	1643	2.04	41545	2 5 C		
0.50	2696.62	1797	1.87	41545	2 8 C		
0.41	3304.80	2194	1.53	41545	3 2 C		
0.36	3760.71	2492	1.31	41545	3 6 C		
0.71	1908.45	1307	3.77	53383	C 0 9 4 1 1 8 C _ M _ _ _ _ . 1 2 A _ _	209.5	63
0.65	2106.88	1440	3.44	53383	2 0 C		
0.60	2250.46	1538	3.20	53383	2 2 C		
0.55	2484.44	1694	2.92	53383	2 5 C		
0.50	2720.42	1852	2.67	53383	2 8 C		
0.41	3333.96	2262	2.19	53383	3 2 C		
0.36	3774.96	2554	1.93	53383	3 6 C		
101	8.59	9	9.52	2860	C 0 3 2 1 8 . 0 _ M _ _ _ _ . 1 2 C _ _	14.5	63
75	11.61	12	7.78	2860	1 1 .		
66	13.20	14	7.04	2860	1 2 .		
58	14.95	15	6.45	2860	1 4 .		
53	16.36	15	6.26	2860	1 6 .		
45	19.12	20	5.38	2850	1 8 .		
42	20.61	21	5.11	2850	2 0 .		
39	22.11	20	5.11	2850	2 2 .		
35	25.14	22	4.67	2850	2 5 .		
31	28.48	25	4.29	2850	2 8 .		
26	33.71	34	3.59	2850	3 2 .		
24	36.43	32	3.61	2850	3 6 .		
22	39.26	34	3.43	2850	4 0 .		
19	45.50	46	2.98	2840	4 5 .		
16	53.31	53	2.70	2830	5 0 .		
15	56.19	49	2.67	2840	5 6 .		
14	64.21	55	2.44	2830	6 3 .		
12	74.55	74	2.01	2820	7 1 .		
11	82.83	81	1.82	2820	8 0 .		
10	86.67	73	2.04	2830	9 0 .		
8.6	101.54	84	1.76	2820	1 0 0		
7.6	114.33	112	1.14	2800	1 1 2		
6.7	129.94	126	0.99	2800	1 2 5		
6.1	142.00	116	1.28	2800	1 4 0		
5.5	157.78	128	1.16	2800	1 6 0		
4.0	217.78	174	0.85	2770	2 1 2		
8.3	105.36	102	1.46	2810	C 0 3 3 1 1 0 0 _ M _ _ _ _ . 1 2 C _ _	17.5	63
7.2	120.39	116	1.28	2800	1 1 8		
6.7	130.10	104	1.42	2810	1 3 2		
6.2	140.21	112	1.32	2800	1 5 0		
5.4	162.50	155	0.96	2780	1 6 0		
4.6	190.38	181	0.82	2770	1 8 0		
4.3	200.68	157	0.94	2780	2 0 0		
3.8	229.32	179	0.83	2770	2 2 5		
16	53.31	54	3.78	5290	C 0 4 2 1 5 0 . _ M _ _ _ _ . 1 2 C _ _	16.5	63
14	64.21	56	3.90	5290	6 3 .		
12	74.55	74	2.71	5290	7 1 .		

0.12 kW
6 POLE

NOTE:
Other output speeds are available using 2 & 8 pole motors. Please contact our Application Engineers

SERIES C SELECTION TABLE GEARED MOTORS

012.kW
6 POLE

N2 RPM	i	M2 Nm	Fm	N	Unit Designation	kg	
Output Speed	Ratio	Output Torque	Service Factor	Overhung Load	Column Entry 1 - 20 Spaces to be filled when entering order	Weight of Base Mount unit	Motor Size
11	82.83	82	2.28	5290	C 0 4 2 1 8 0 . _ M _ - _ - _ . 1 2 C - -	16.5	63
10	86.67	74	3.31	5290	9 0 .		
8.6	101.54	86	2.95	5290	1 0 0		
7.6	114.33	113	1.14	5290	1 1 2		
6.7	129.94	127	0.99	5280	1 2 5		
6.1	142.00	118	2.35	5290	1 4 0		
5.5	157.78	130	2.13	5280	1 6 0		
4.0	217.78	176	1.14	5270	2 1 2		
3.5	247.50	198	0.99	5260	2 5 0		
8.3	105.36	103	1.94	5290	C 0 4 3 1 1 0 0 _ M _ - _ - _ . 1 2 C - -	20.5	63
7.2	120.39	117	1.70	5290	1 1 8		
6.7	130.10	107	2.55	5290	1 3 2		
6.2	140.21	115	2.40	5290	1 5 0		
5.4	162.50	156	1.26	5280	1 6 0		
4.6	190.38	182	1.08	5270	1 8 0		
4.3	200.68	162	1.71	5280	2 0 0		
3.8	229.32	184	1.51	5270	2 2 5		
2.8	309.52	243	1.14	5250	3 1 5		
2.4	362.64	283	0.98	5240	3 6 0		
8.0	109.07	111	3.49	7440	C 0 5 2 1 1 1 2 _ M _ - _ - _ . 1 2 C - -	18.5	63
7.0	124.00	125	3.04	7440	1 2 5		
6.1	142.00	122	3.93	7440	1 4 0		
5.4	160.00	136	3.52	7440	1 6 0		
4.1	211.11	178	2.70	7440	2 1 2		
3.6	240.00	200	2.40	7440	2 5 0		
8.4	103.90	105	3.76	7440	C 0 5 3 1 1 0 0 _ M _ - _ - _ . 1 2 C - -	21.5	63
7.3	118.73	119	3.29	7440	1 1 8		
5.4	160.26	159	2.45	7440	1 6 0		
4.6	187.76	186	2.08	7440	1 8 0		
4.3	201.10	168	2.85	7440	2 0 0		
3.8	229.81	191	2.51	7440	2 2 5		
3.3	262.58	257	1.50	7440	2 6 5		
3.0	291.75	284	1.35	7440	2 8 0		
2.8	310.18	254	1.90	7440	3 1 5		
2.4	363.40	295	1.63	7440	3 6 0		
2.2	402.70	391	0.97	7430	4 0 0		
1.9	457.66	441	0.86	7420	4 5 0		
1.7	508.21	406	1.19	7430	5 0 0		
1.5	564.68	449	1.07	7420	5 6 0		
7.0	124.00	132	3.95	11900	C 0 6 2 1 1 2 5 _ M _ - _ - _ . 1 2 C - -	32.5	63
3.6	240.00	211	3.62	11900	2 5 0		
4.7	184.62	193	3.95	11900	C 0 6 3 1 1 8 0 _ M _ - _ - _ . 1 2 C - -	37.5	63
3.3	265.95	275	2.78	11800	2 6 5		
2.9	299.67	309	2.48	11800	2 8 0		
2.6	328.67	282	2.71	11800	3 1 5		
2.4	357.32	305	2.51	11800	3 6 0		
2.2	395.39	405	1.89	11700	4 0 0		
1.9	449.50	458	1.67	11700	4 5 0		
1.7	514.75	431	1.77	11700	5 0 0		
1.5	580.00	482	1.59	11700	5 6 0		
1.1	765.28	629	1.22	11600	8 0 0		
1.0	870.00	709	1.08	11500	9 0 0		
2.7	319.95	323	3.93	29200	C 0 7 3 1 3 1 5 _ M _ - _ - _ . 1 2 C - -	84.5	63
2.5	341.61	344	3.69	29200	3 6 0		
2.3	373.83	400	3.35	29200	4 0 0		
2.1	419.25	446	3.00	29200	4 5 0		
1.7	499.88	495	2.55	29200	5 0 0		
1.6	547.35	539	2.33	29200	5 6 0		
1.2	747.66	731	1.72	29200	8 0 0		
1.0	838.50	817	1.54	29200	9 0 0		
0.86	1009.20	1059	1.27	28931	C 0 7 4 1 1 0 C _ M _ - _ - _ . 1 2 C - -	88.5	63
0.79	1097.19	1150	1.17	28931	1 1 C		
0.72	1213.28	1260	1.06	28931	1 2 C		
0.62	1395.57	1446	0.93	28931	1 4 C		
0.57	1517.24	1570	0.85	28931	1 6 C		
1.4	636.31	682	3.98	41656	C 0 8 4 1 6 3 0 _ M _ - _ - _ . 1 2 C - -	141.5	63
1.2	711.92	761	3.57	41656	7 1 0		
1.1	758.79	812	3.34	41656	8 0 0		
0.97	899.27	959	2.83	41656	9 0 0		
0.91	960.14	1023	2.65	41656	1 0 C		
0.80	1083.79	1151	2.47	41656	1 1 C		
0.73	1191.45	1264	2.15	41656	1 2 C		
0.62	1404.96	1484	1.83	41656	1 4 C		
0.57	1532.14	1610	2.03	41545	1 6 C		
0.46	1901.25	1991	1.64	41545	1 8 C		
0.42	2088.45	2180	1.54	41545	2 0 C		
0.39	2241.96	2340	1.40	41545	2 2 C		
0.35	2462.71	2563	1.31	41545	2 5 C		
0.32	2696.62	2801	1.20	41545	2 8 C		
0.26	3304.80	3414	0.98	41545	3 2 C		

NOTE:
Other output speeds are available using 2 & 8 pole motors. Please contact our Application Engineers

SERIES C SELECTION TABLE GEARED MOTORS

012.kW
6 POLE

0.18 kW
4 POLE

N2 RPM	i	M2 Nm	Fm	N	Unit Designation	kg			
Output Speed	Ratio	Output Torque	Service Factor	Overhung Load	Column Entry 1 - 20 Spaces to be filled when entering order	Weight of Base Mount unit	Motor Size		
0.23	3760.71	3866	0.85	41545	C 0 8 4 1 3 6 C _ M _ _ _ _ . 1 2 C - -	141.5	63		
0.72	1216.09	1319	3.62	53383	C 0 9 4 1 1 2 C _ M _ _ _ _ . 1 2 C - -	209.5	63		
0.61	1434.02	1549	3.09	53383	1 4 C				
0.57	1537.95	1649	2.99	53383	1 6 C				
0.46	1908.45	2039	2.41	53383	1 8 C				
0.41	2106.88	2247	2.20	53383	2 0 C				
0.39	2250.46	2397	2.05	53383	2 2 C				
0.35	2484.44	2641	1.88	53383	2 5 C				
0.32	2720.42	2886	1.72	53383	2 8 C				
0.26	3333.96	3518	1.41	53383	3 2 C				
0.23	3774.96	3963	1.24	53383	3 6 C				
159	8.59	8	9.03	2858	C 0 3 2 1 8 . 0 _ M _ _ _ _ . 1 8 A - -	14.5	63		
118	11.61	12	7.30	2857	1 1 .				
104	13.20	13	6.67	2857	1 2 .				
92	14.95	15	6.09	2857	1 4 .				
84	16.36	14	5.83	2856	1 6 .				
72	19.12	19	5.11	2856	1 8 .				
66	20.61	20	4.84	2856	2 0 .				
62	22.11	19	4.77	2856	2 2 .				
54	25.14	22	4.36	2855	2 5 .				
48	28.48	25	4.02	2855	2 8 .				
41	33.71	33	3.38	2844	3 2 .				
38	36.43	31	3.39	2844	3 6 .				
35	39.26	34	3.22	2844	4 0 .				
30	45.50	44	2.72	2841	4 5 .				
26	53.31	52	2.44	2831	5 0 .				
24	56.19	47	2.51	2841	5 6 .				
21	64.21	54	2.29	2830	6 3 .				
18	74.55	71	2.00	2825	7 1 .				
17	82.83	79	1.85	2818	8 0 .				
16	86.67	71	1.94	2825	9 0 .				
13	101.54	82	1.73	2816	1 0 0				
12	114.33	107	1.20	2801	1 1 2				
11	129.94	122	1.03	2796	1 2 5				
10	142.00	113	1.32	2801	1 4 0				
8.7	157.78	124	1.20	2796	1 6 0				
6.3	217.78	168	0.88	2770	2 1 2				
13	105.36	98	1.52	2810	C 0 3 3 1 1 0 0 _ M _ _ _ _ . 1 8 A - -	17.5	63		
11	120.39	111	1.33	2801	1 1 8				
11	130.10	102	1.45	2811	1 3 2				
10	140.21	109	1.36	2801	1 5 0				
8.4	162.50	149	1.00	2782	1 6 0				
7.2	190.38	174	0.86	2770	1 8 0				
6.8	200.68	153	0.97	2780	2 0 0				
6.0	229.32	174	0.86	2770	2 2 5				
26	53.31	52	3.97	5286	C 0 4 2 1 5 0 . _ M _ _ _ _ . 1 8 A - -			16.5	63
21	64.21	55	3.67	5286	6 3 .				
18	74.55	72	2.84	5284	7 1 .				
17	82.83	80	2.39	5284	8 0 .				
16	86.67	73	3.11	5287	9 0 .				
13	101.54	84	2.77	5285	1 0 0				
12	114.33	108	1.20	5280	1 1 2				
11	129.94	123	1.03	5278	1 2 5				
10	142.00	115	2.18	5280	1 4 0				
8.7	157.78	127	2.02	5278	1 6 0				
6.3	217.78	172	1.20	5271	2 1 2				
5.5	247.50	194	1.03	5261	2 5 0				
13	105.36	99	2.04	5281	C 0 4 3 1 1 0 0 _ M _ _ _ _ . 1 8 A - -	20.5	63		
11	120.39	113	1.78	5280	1 1 8				
11	130.10	104	2.28	5281	1 3 2				
10	140.21	112	2.18	5280	1 5 0				
8.4	162.50	151	1.32	5275	1 6 0				
7.2	190.38	176	1.13	5270	1 8 0				
6.8	200.68	157	1.75	5275	2 0 0				
6.0	229.32	178	1.55	5271	2 2 5				
5.1	266.25	244	0.81	5246	2 6 5				
4.4	309.52	237	1.17	5250	3 1 5				
3.8	362.64	275	1.01	5240	3 6 0				
13	109.07	107	3.66	7438	C 0 5 2 1 1 1 2 _ M _ _ _ _ . 1 8 A - -	18.5	63		
11	124.00	121	3.19	7438	1 2 5				
8.6	160.00	133	3.61	7436	1 6 0				
6.5	211.11	173	2.78	7433	2 1 2				
5.7	240.00	195	2.47	7437	2 5 0				

NOTE:
Other output speeds are available using 2 & 8 pole motors. Please contact our Application Engineers

SERIES C SELECTION TABLE GEARED MOTORS

0.18 kW

4 POLE

N2 RPM	i	M2 Nm	Fm	N	Unit Designation	kg	
Output Speed	Ratio	Output Torque	Service Factor	Overhung Load	Column Entry 1 - 20 Spaces to be filled when entering order	Weight of Base Mount unit	Motor Size
13	103.90	101	3.95	7436	C 0 5 3 1 1 0 0 _ M _ _ _ _ . 1 8 A - -	21.5	63
12	118.73	115	3.46	7435	1 1 8		
8.5	160.26	153	2.57	7434	1 6 0		
7.3	187.76	179	2.19	7434	1 8 0		
6.8	201.10	163	2.94	7435	2 0 0		
6.0	229.81	186	2.59	7434	2 2 5		
5.2	262.58	247	1.57	7432	2 6 5		
4.7	291.75	273	1.42	7430	2 8 0		
4.4	310.18	246	1.95	7432	3 1 5		
3.8	363.40	286	1.68	7428	3 6 0		
3.4	402.70	374	1.03	7421	4 0 0		
3.0	457.66	425	0.90	7416	4 5 0		
2.7	508.21	394	1.22	7421	5 0 0		
2.4	564.68	435	1.11	7420	5 6 0		
1.8	779.42	592	0.81	7390	8 0 0		
5.7	240.00	206	3.71	11852	C 0 6 2 1 2 5 0 _ M _ _ _ _ . 1 8 A - -	32.5	63
5.2	265.95	265	2.89	11830	C 0 6 3 1 2 6 5 _ M _ _ _ _ . 1 8 A - -	37.5	63
4.6	299.67	297	2.57	11728	2 8 0		
4.2	328.67	275	2.78	11828	3 1 5		
3.8	357.32	297	2.57	11828	3 6 0		
3.5	395.39	390	1.96	11704	4 0 0		
3.0	449.50	440	1.74	11661	4 5 0		
2.7	514.75	419	1.83	11707	5 0 0		
2.4	580.00	469	1.63	11707	5 6 0		
1.8	765.28	610	1.25	11600	8 0 0		
1.6	870.00	688	1.11	11500	9 0 0		
4.0	341.61	330	3.84	28143	C 0 7 3 1 3 6 0 _ M _ _ _ _ . 1 8 A - -	84.5	63
3.7	373.83	384	3.49	27930	4 0 0		
3.3	419.25	429	3.12	29161	4 5 0		
2.7	499.88	479	2.65	29152	5 0 0		
2.5	547.35	522	2.43	29152	5 6 0		
1.8	747.66	701	1.80	29130	8 0 0		
1.6	838.50	784	1.61	29116	9 0 0		
1.4	1009.20	1012	1.33	28931	C 0 7 4 1 1 0 0 C _ M _ _ _ _ . 1 8 A - -	88.5	63
1.2	1097.19	1099	1.22	28931	1 1 C		
1.1	1213.28	1201	1.12	28931	1 2 C		
0.98	1395.57	1379	0.97	28931	1 4 C		
0.90	1517.24	1498	0.90	28931	1 6 C		
0.82	1661.54	1634	0.82	28931	1 8 C		
1.9	711.92	726	3.74	41656	C 0 8 4 1 7 1 0 _ M _ _ _ _ . 1 8 A - -	141.5	63
1.8	758.79	774	3.51	41656	8 0 0		
1.5	899.27	916	2.96	41656	9 0 0		
1.4	960.14	977	2.78	41656	1 0 C		
1.3	1083.79	1098	2.59	41656	1 1 C		
1.1	1191.45	1209	2.25	41656	1 2 C		
0.98	1404.96	1421	1.91	41656	1 4 C		
0.89	1532.14	1534	2.14	41545	1 6 C		
0.72	1901.25	1900	1.72	41545	1 8 C		
0.66	2088.45	2079	1.61	41545	2 0 C		
0.61	2241.96	2236	1.47	41545	2 2 C		
0.56	2462.71	2447	1.37	41545	2 5 C		
0.51	2696.62	2676	1.25	41545	2 8 C		
0.41	3304.80	3268	1.03	41545	3 2 C		
0.36	3760.71	3711	0.88	41545	3 6 C		
1.1	1216.09	1261	3.79	53383	C 0 9 4 1 1 2 C _ M _ _ _ _ . 1 8 A - -	209.5	63
0.96	1434.02	1483	3.22	53383	1 4 C		
0.89	1537.95	1572	3.13	53383	1 6 C		
0.72	1908.45	1947	2.53	53383	1 8 C		
0.65	2106.88	2144	2.31	53383	2 0 C		
0.61	2250.46	2291	2.15	53383	2 2 C		
0.55	2484.44	2523	1.96	53383	2 5 C		
0.50	2720.42	2759	1.80	53383	2 8 C		
0.41	3333.96	3368	1.47	53383	3 2 C		
0.36	3774.96	3803	1.30	53383	3 6 C		

NOTE:

Other output speeds are available using 2 & 8 pole motors. Please contact our Application Engineers

SERIES C SELECTION TABLE GEARED MOTORS

0.18 kW

6 POLE

N2 RPM	i	M2 Nm	Fm	N	Unit Designation	kg	
Output Speed	Ratio	Output Torque	Service Factor	Overhung Load	Column Entry 1 - 20 Spaces to be filled when entering order	Weight of Base Mount unit	Motor Size
105	8.59	13	6.56	2857	C 0 3 2 1 8 . 0 _ M _ _ _ . 1 8 C - -	15.5	71
78	11.61	17	5.36	2856	1 1 .		
68	13.20	20	4.85	2856	1 2 .		
60	14.95	22	4.45	2855	1 4 .		
55	16.36	22	4.32	2855	1 6 .		
47	19.12	29	3.71	2845	1 8 .		
44	20.61	31	3.52	2844	2 0 .		
41	22.11	29	3.53	2845	2 2 .		
36	25.14	33	3.22	2844	2 5 .		
32	28.48	37	2.96	2843	2 8 .		
27	33.71	50	2.48	2840	3 2 .		
25	36.43	46	2.49	2841	3 6 .		
23	39.26	50	2.36	2840	4 0 .		
20	45.50	67	2.06	2827	4 5 .		
17	53.31	77	1.86	2816	5 0 .		
16	56.19	71	1.84	2827	5 6 .		
14	64.21	80	1.68	2816	6 3 .		
12	74.55	107	1.39	2800	7 1 .		
11	82.83	118	1.26	2798	8 0 .		
10	86.67	105	1.41	2810	9 0 .		
8.9	101.54	122	1.21	2796	1 0 0		
6.3	142.00	168	0.89	2772	1 4 0		
5.7	157.78	185	0.80	2338	1 6 0		
8.5	105.36	148	1.01	2135	C 0 3 3 1 1 0 0 _ M _ _ _ . 1 8 C - -	19.5	71
7.5	120.39	168	0.89	2772	1 1 8		
6.9	130.10	152	0.98	2782	1 3 2		
6.4	140.21	163	0.91	2772	1 5 0		
25	36.43	48	3.97	5286	C 0 4 2 1 3 6 . _ M _ _ _ . 1 8 C - -	18.5	71
23	39.26	51	3.79	5286	4 0 .		
20	45.50	67	3.05	5285	4 5 .		
17	53.31	79	2.60	5284	5 0 .		
16	56.19	72	2.95	5285	5 6 .		
14	64.21	81	2.69	5283	6 3 .		
12	74.55	108	1.87	5281	7 1 .		
11	82.83	120	1.57	5278	8 0 .		
10	86.67	108	2.28	5280	9 0 .		
8.9	101.54	125	2.03	5278	1 0 0		
6.3	142.00	171	1.62	5273	1 4 0		
5.7	157.78	189	1.47	5263	1 6 0		
8.5	105.36	150	1.34	5276	C 0 4 3 1 1 0 0 _ M _ _ _ . 1 8 C - -	21.5	71
7.5	120.39	170	1.17	5273	1 1 8		
6.9	130.10	156	1.76	5274	1 3 2		
6.4	140.21	167	1.66	5273	1 5 0		
5.5	162.50	227	0.87	5256	1 6 0		
4.5	200.68	235	1.18	5256	2 0 0		
3.9	229.32	266	1.04	5242	2 2 5		
12	73.37	109	3.64	7436	C 0 5 2 1 7 1 . _ M _ _ _ . 1 8 C - -	21.5	71
11	82.67	123	3.23	7435	8 0 .		
9.1	98.57	126	3.81	7435	1 0 0		
8.3	109.07	161	2.41	7434	1 1 2		
7.3	124.00	181	2.09	7434	1 2 5		
6.3	142.00	177	2.71	7434	1 4 0		
5.6	160.00	198	2.43	7431	1 6 0		
4.3	211.11	258	1.86	6731	2 1 2		
3.8	240.00	291	1.66	7428	2 5 0		
8.7	103.90	152	2.59	7037	C 0 5 3 1 1 0 0 _ M _ _ _ . 1 8 C - -	25.5	71
7.6	118.73	173	2.27	6984	1 1 8		
6.9	130.38	162	2.96	6984	1 3 2		
6.4	140.51	174	2.77	6984	1 5 0		
5.6	160.26	231	1.69	6731	1 6 0		
4.8	187.76	269	1.44	7427	1 8 0		
4.5	201.10	244	1.97	7430	2 0 0		
3.9	229.81	277	1.73	7427	2 2 5		
3.4	262.58	373	1.03	7420	2 6 5		
3.1	291.75	411	0.93	7418	2 8 0		
2.9	310.18	368	1.31	7423	3 1 5		
2.5	363.40	428	1.12	7094	3 6 0		
1.8	508.21	589	0.82	7393	5 0 0		
7.3	124.00	192	2.72	11852	C 0 6 2 1 1 2 5 _ M _ _ _ . 1 8 C - -	34.5	71
5.7	156.67	206	3.71	11852	1 6 0		
4.2	214.00	275	2.78	11833	2 1 2		
3.8	240.00	307	2.49	11823	2 5 0		
5.3	169.81	259	2.95	11833	C 0 6 3 1 1 6 0 _ M _ _ _ . 1 8 C - -	39.5	71
4.9	184.62	281	2.72	11823	1 8 0		
3.4	265.95	399	1.92	11702	2 6 5		
3.0	299.67	448	1.71	11680	2 8 0		
2.7	328.67	409	1.87	11704	3 1 5		
2.5	357.32	442	1.73	11704	3 6 0		
2.3	395.39	588	1.30	11556	4 0 0		
2.0	449.50	665	1.15	11515	4 5 0		
1.7	514.75	625	1.22	11561	5 0 0		

NOTE:

Other output speeds are available using 2 & 8 pole motors. Please contact our Application Engineers

SERIES C SELECTION TABLE GEARED MOTORS

0.18 kW
6 POLE

N2 RPM	i	M2 Nm	Fm	N	Unit Designation	kg	
Output Speed	Ratio	Output Torque	Service Factor	Overhung Load	Column Entry 1 - 20 Spaces to be filled when entering order	Weight of Base Mount unit	Motor Size
1.6	580.00	700	1.09	11515	C 0 6 3 1 5 6 0 _ M _ _ _ _ . 1 8 C - -	39.5	71
1.2	765.28	913	0.84	11400	8 0 0		
4.0	226.39	334	3.79	29180	C 0 7 3 1 2 2 5 _ M _ _ _ _ . 1 8 C - -	86.5	71
3.6	249.94	392	3.41	29171	2 6 5		
3.3	273.68	428	3.12	29161	2 8 0		
2.8	319.95	468	2.71	29161	3 1 5		
2.6	341.61	499	2.54	29152	3 6 0		
2.4	373.83	580	2.31	29144	4 0 0		
2.1	419.25	648	2.07	29144	4 5 0		
1.8	499.88	717	1.76	29130	5 0 0		
1.6	547.35	782	1.61	29116	5 6 0		
1.2	747.66	1061	1.19	29080	8 0 0		
1.1	838.50	1185	1.06	29056	9 0 0		
0.89	1009.20	1536	0.87	28931	C 0 7 4 1 1 0 C _ M _ _ _ _ . 1 8 C - -	90.5	71
0.82	1097.19	1667	0.80	28931	1 1 C		
1.6	547.09	852	3.19	41656	C 0 8 4 1 5 6 0 _ M _ _ _ _ . 1 8 C - -	143.5	71
1.4	636.31	989	2.74	41656	6 3 0		
1.3	711.92	1104	2.46	41656	7 1 0		
1.2	758.79	1177	2.31	41656	8 0 0		
1.0	899.27	1391	1.95	41656	9 0 0		
0.94	960.14	1484	1.83	41656	1 0 C		
0.83	1083.79	1669	1.70	41656	1 1 C		
0.76	1191.45	1833	1.48	41656	1 2 C		
0.64	1404.96	2152	1.26	41656	1 4 C		
0.59	1532.14	2335	1.40	41545	1 6 C		
0.47	1901.25	2887	1.13	41545	1 8 C		
0.43	2088.45	3162	1.06	41545	2 0 C		
0.40	2241.96	3394	0.97	41545	2 2 C		
0.37	2462.71	3716	0.90	41545	2 5 C		
0.33	2696.62	4061	0.83	41545	2 8 C		
1.2	774.48	1227	3.90	53383	C 0 9 4 1 8 0 0 _ M _ _ _ _ . 1 8 C - -	211.5	71
0.98	917.87	1451	3.29	53383	9 0 0		
0.92	980.00	1547	3.09	53383	1 0 C		
0.83	1088.78	1713	2.81	53383	1 1 C		
0.74	1216.09	1912	2.50	53383	1 2 C		
0.63	1434.02	2246	2.13	53383	1 4 C		
0.59	1537.95	2391	2.06	53383	1 6 C		
0.47	1908.45	2957	1.67	53383	1 8 C		
0.43	2106.88	3258	1.52	53383	2 0 C		
0.40	2250.46	3476	1.42	53383	2 2 C		
0.36	2484.44	3830	1.29	53383	2 5 C		
0.33	2720.42	4185	1.18	53383	2 8 C		
0.27	3333.96	5102	0.97	53383	3 2 C		
0.24	3774.96	5746	0.86	53383	3 6 C		
163	8.59	12	6.64	2856	C 0 3 2 1 8 . 0 _ M _ _ _ _ . 2 5 A - -	15.5	71
121	11.61	16	5.37	2855	1 1 .		
106	13.20	18	4.90	2854	1 2 .		
94	14.95	20	4.48	2854	1 4 .		
86	16.36	20	4.29	2853	1 6 .		
73	19.12	26	3.76	2852	1 8 .		
68	20.61	28	3.56	2852	2 0 .		
63	22.11	26	3.51	2852	2 2 .		
56	25.14	30	3.21	2849	2 5 .		
49	28.48	34	2.95	2849	2 8 .		
42	33.71	45	2.49	2837	3 2 .		
38	36.43	42	2.49	2837	3 6 .		
36	39.26	46	2.37	2837	4 0 .		
31	45.50	60	2.00	2831	4 5 .		
26	53.31	70	1.79	2821	5 0 .		
25	56.19	64	1.85	2831	5 6 .		
22	64.21	73	1.69	2818	6 3 .		
19	74.55	97	1.47	2808	7 1 .		
17	82.83	107	1.36	2804	8 0 .		
16	86.67	97	1.43	2808	9 0 .		
14	101.54	112	1.27	2800	1 0 0		
12	114.33	146	0.88	2780	1 1 2		
10	142.00	153	0.97	2780	1 4 0		
8.9	157.78	169	0.88	2770	1 6 0		
13	105.36	133	1.12	2788	C 0 3 3 1 1 0 0 _ M _ _ _ _ . 2 5 A - -	19.5	71
12	120.39	151	0.98	2780	1 1 8		
11	130.10	138	1.07	2790	1 3 2		
10	140.21	148	1.00	2780	1 5 0		

NOTE:
Other output speeds are available using 2 & 8 pole motors. Please contact our Application Engineers

SERIES C SELECTION TABLE GEARED MOTORS

0.25 kW

4 POLE

N2 RPM	i	M2 Nm	Fm	N	Unit Designation	kg	
Output Speed	Ratio	Output Torque	Service Factor	Overhung Load	Column Entry 1 - 20 Spaces to be filled when entering order	Weight of Base Mount unit	Motor Size
38	36.43	44	3.98	5286	C 0 4 2 1 3 6 . _ M _ - _ - _ . 2 5 A - -	18.5	71
36	39.26	47	3.78	5286	4 0 .		
31	45.50	61	3.35	5285	4 5 .		
26	53.31	71	2.92	5281	5 0 .		
25	56.19	66	2.96	5283	5 6 .		
22	64.21	74	2.70	5281	6 3 .		
19	74.55	98	2.09	5277	7 1 .		
17	82.83	109	1.76	5277	8 0 .		
16	86.67	99	2.29	5284	9 0 .		
14	101.54	114	2.04	5279	1 0 0		
12	114.33	147	0.88	5269	1 1 2		
10	142.00	156	1.61	5269	1 4 0		
8.9	157.78	172	1.49	5264	1 6 0		
6.4	217.78	233	0.88	5250	2 1 2		
13	105.36	135	1.50	5271	C 0 4 3 1 1 0 0 _ M _ - _ - _ . 2 5 A - -	21.5	71
12	120.39	154	1.31	5268	1 1 8		
11	130.10	142	1.68	5271	1 3 2		
10	140.21	152	1.61	5269	1 5 0		
8.6	162.50	206	0.97	5258	1 6 0		
7.4	190.38	239	0.83	5248	1 8 0		
7.0	200.68	213	1.29	5258	2 0 0		
6.1	229.32	243	1.14	5250	2 2 5		
19	73.37	99	3.83	7437	C 0 5 2 1 7 1 . _ M _ - _ - _ . 2 5 A - -	21.5	71
17	82.67	111	3.45	7436	8 0 .		
13	109.07	145	2.70	7435	1 1 2		
11	124.00	164	2.34	7436	1 2 5		
10	142.00	162	2.97	7436	1 4 0		
8.8	160.00	181	2.65	7431	1 6 0		
6.6	211.11	235	2.04	7425	2 1 2		
5.8	240.00	265	1.82	7434	2 5 0		
13	103.90	137	2.91	7433	C 0 5 3 1 1 0 0 _ M _ - _ - _ . 2 5 A - -	25.5	71
12	118.73	156	2.55	7430	1 1 8		
11	130.38	148	3.25	7432	1 3 2		
10	140.51	159	3.03	7430	1 5 0		
8.7	160.26	209	1.89	7427	1 6 0		
7.5	187.76	243	1.61	7427	1 8 0		
7.0	201.10	222	2.16	7430	2 0 0		
6.1	229.81	253	1.90	7427	2 2 5		
5.3	262.58	335	1.16	7424	2 6 5		
4.8	291.75	372	1.04	7419	2 8 0		
4.5	310.18	335	1.44	7424	3 1 5		
3.9	363.40	390	1.24	7414	3 6 0		
2.8	508.21	535	0.90	7400	5 0 0		
11	124.00	173	3.05	11838	C 0 6 2 1 1 2 5 _ M _ - _ - _ . 2 5 A - -	34.5	71
6.5	214.00	252	3.03	11817	2 1 2		
5.8	240.00	280	2.73	11796	2 5 0		
8.2	169.81	234	3.27	11817	C 0 6 3 1 1 6 0 _ M _ - _ - _ . 2 5 A - -	39.5	71
7.6	184.62	253	3.02	11796	1 8 0		
5.3	265.95	360	2.12	11748	2 6 5		
4.7	299.67	404	1.89	11644	2 8 0		
4.3	328.67	374	2.05	11744	3 1 5		
3.9	357.32	404	1.89	11744	3 6 0		
3.5	395.39	530	1.44	11592	4 0 0		
3.1	449.50	599	1.28	11500	4 5 0		
2.7	514.75	569	1.34	11600	5 0 0		
2.4	580.00	637	1.20	11600	5 6 0		
5.6	249.94	354	3.78	29152	C 0 7 3 1 2 6 5 _ M _ - _ - _ . 2 5 A - -	86.5	71
5.1	273.68	386	3.46	29143	2 8 0		
4.4	319.95	422	3.01	28013	3 1 5		
4.1	341.61	449	2.82	26909	3 6 0		
3.7	373.83	522	2.56	26449	4 0 0		
3.3	419.25	584	2.29	29117	4 5 0		
2.8	499.88	651	1.95	29096	5 0 0		
2.6	547.35	710	1.79	29096	5 6 0		
1.9	747.66	953	1.32	29048	8 0 0		
1.7	838.50	1066	1.18	29018	9 0 0		
1.4	1009.20	1375	0.97	28931	C 0 7 4 1 1 0 C _ M _ - _ - _ . 2 5 A - -	90.5	71
1.3	1097.19	1494	0.90	28931	1 1 C		
1.2	1213.28	1632	0.82	28931	1 2 C		
2.6	547.09	760	3.57	41656	C 0 8 4 1 5 6 0 _ M _ - _ - _ . 2 5 A - -	143.5	71
2.2	636.31	883	3.07	41656	6 3 0		
2.0	711.92	986	2.75	41656	7 1 0		
1.8	758.79	1052	2.58	41656	8 0 0		
1.6	899.27	1245	2.18	41656	9 0 0		
1.5	960.14	1328	2.04	41656	1 0 C		
1.3	1083.79	1493	1.90	41656	1 1 C		
1.2	1191.45	1643	1.65	41656	1 2 C		
0.99	1404.96	1932	1.41	41656	1 4 C		

NOTE:

Other output speeds are available using 2 & 8 pole motors. Please contact our Application Engineers

SERIES C SELECTION TABLE GEARED MOTORS

0.25 kW
4 POLE

0.25 kW
6 POLE

N2 RPM	i	M2 Nm	Fm	N	Unit Designation	kg	
Output Speed	Ratio	Output Torque	Service Factor	Overhung Load	Column Entry 1 - 20 Spaces to be filled when entering order	Weight of Base Mount unit	Motor Size
0.91	1532.14	2085	1.57	41545	C 0 8 4 1 1 6 C _ M _ _ _ _ . 2 5 A _ _	143.5	71
0.74	1901.25	2582	1.27	41545	1 8 C		
0.67	2088.45	2826	1.19	41545	2 0 C		
0.62	2241.96	3039	1.08	41545	2 2 C		
0.57	2462.71	3326	1.01	41545	2 5 C		
0.52	2696.62	3637	0.92	41545	2 8 C		
1.5	917.87	1298	3.68	53383	C 0 9 4 1 9 0 0 _ M _ _ _ _ . 2 5 A _ _	211.5	71
1.4	980.00	1385	3.45	53383	1 0 C		
1.3	1088.78	1533	3.14	53383	1 1 C		
1.2	1216.09	1713	2.79	53383	1 2 C		
0.98	1434.02	2015	2.37	53383	1 4 C		
0.91	1537.95	2137	2.30	53383	1 6 C		
0.73	1908.45	2646	1.86	53383	1 8 C		
0.66	2106.88	2914	1.70	53383	2 0 C		
0.62	2250.46	3113	1.58	53383	2 2 C		
0.56	2484.44	3429	1.44	53383	2 5 C		
0.51	2720.42	3749	1.32	53383	2 8 C		
0.42	3333.96	4578	1.08	53383	3 2 C		
0.37	3774.96	5168	0.95	53383	3 6 C		
105	8.59	18	4.72	2854	C 0 3 2 1 8 . 0 _ M _ _ _ _ . 2 5 C _ _	15.5	71
78	11.61	24	3.86	2852	1 1 .		
68	13.20	28	3.49	2851	1 2 .		
60	14.95	31	3.20	2850	1 4 .		
55	16.36	30	3.11	2850	1 6 .		
47	19.12	40	2.67	2839	1 8 .		
44	20.61	43	2.54	2838	2 0 .		
41	22.11	40	2.54	2839	2 2 .		
36	25.14	46	2.32	2837	2 5 .		
32	28.48	52	2.13	2835	2 8 .		
27	33.71	70	1.79	2829	3 2 .		
25	36.43	65	1.79	2831	3 6 .		
23	39.26	70	1.70	2829	4 0 .		
20	45.50	93	1.48	2812	4 5 .		
17	53.31	108	1.34	2799	5 0 .		
16	56.19	98	1.33	2812	5 6 .		
14	64.21	111	1.21	2799	6 3 .		
12	74.55	149	1.00	2778	7 1 .		
11	82.83	164	0.9	2773	8 0 .		
10	86.67	147	1.01	2788	9 0 .		
8.9	101.54	170	0.87	2770	1 0 0		
36	25.14	47	3.70	5285	C 0 4 2 1 2 5 . _ M _ _ _ _ . 2 5 C _ _	18.5	71
32	28.48	53	3.40	5284	2 8 .		
27	33.71	70	2.95	5281	3 2 .		
25	36.43	67	2.86	5283	3 6 .		
23	39.26	71	2.73	5282	4 0 .		
20	45.50	94	2.19	5279	4 5 .		
17	53.31	109	1.88	5277	5 0 .		
16	56.19	100	2.13	5279	5 6 .		
14	64.21	113	1.94	5275	6 3 .		
12	74.55	150	1.35	5271	7 1 .		
11	82.83	166	1.13	5265	8 0 .		
10	86.67	150	1.64	5269	9 0 .		
8.9	101.54	174	1.46	5264	1 0 0		
6.3	142.00	238	1.17	5253	1 4 0		
5.7	157.78	262	1.06	5243	1 6 0		
8.5	105.36	208	0.96	5259	C 0 4 3 1 1 0 0 _ M _ _ _ _ . 2 5 C _ _	21.5	71
7.5	120.39	237	0.84	5253	1 1 8		
6.9	130.10	216	1.26	5256	1 3 2		
6.4	140.21	233	1.19	5253	1 5 0		
4.5	200.68	326	0.85	5228	2 0 0		
12	73.37	152	2.62	7432	C 0 5 2 1 7 1 . _ M _ _ _ _ . 2 5 C _ _	21.5	71
11	82.67	170	2.33	7430	8 0 .		
10	90.67	162	2.97	7430	9 0 .		
9.1	98.57	175	2.74	7429	1 0 0		
8.3	109.07	223	1.73	7427	1 1 2		
7.3	124.00	252	1.51	7427	1 2 5		
6.3	142.00	246	1.95	7427	1 4 0		
5.6	160.00	275	1.75	7421	1 6 0		
4.3	211.11	359	1.34	5904	2 1 2		
3.8	240.00	404	1.19	7414	2 5 0		
8.7	103.90	211	1.87	6567	C 0 5 3 1 1 0 0 _ M _ _ _ _ . 2 5 C _ _	25.5	71
7.6	118.73	240	1.63	6453	1 1 8		
6.9	130.38	225	2.13	6453	1 3 2		
6.4	140.51	242	1.99	6453	1 5 0		

NOTE:
Other output speeds are available using 2 & 8 pole motors. Please contact our Application Engineers

SERIES C SELECTION TABLE GEARED MOTORS

0.25 kW
6 POLE

N2 RPM	i	M2 Nm	Fm	N	Unit Designation	kg	
Output Speed	Ratio	Output Torque	Service Factor	Overhung Load	Column Entry 1 - 20 Spaces to be filled when entering order	Weight of Base Mount unit	Motor Size
5.6	160.26	320	1.22	5904	C 0 5 3 1 1 6 0 _ M _ - - - . 2 5 C - -	25.5	71
4.8	187.76	374	1.03	7412	1 8 0		
4.5	201.10	340	1.42	7418	2 0 0		
3.9	229.81	385	1.25	7412	2 2 5		
2.9	310.18	512	0.94	7403	3 1 5		
2.5	363.40	595	0.81	6691	3 6 0		
11	80.94	176	3.9	11834	C 0 6 2 1 8 0 . _ M _ - - - . 2 5 C - -	34.5	71
8.1	110.57	239	2.99	11807	1 1 2		
7.3	124.00	266	1.96	11796	1 2 5		
6.3	143.08	263	2.91	11817	1 4 0		
5.7	156.67	286	2.67	11796	1 6 0		
4.2	214.00	383	2.00	11755	2 1 2		
3.8	240.00	426	1.8	11734	2 5 0		
5.3	169.81	360	2.13	11755	C 0 6 3 1 1 6 0 _ M _ - - - . 2 5 C - -	39.5	71
4.9	184.62	390	1.96	11734	1 8 0		
3.4	265.95	555	1.38	11588	2 6 5		
3.0	299.67	622	1.23	11540	2 8 0		
2.7	328.67	568	1.35	11592	3 1 5		
2.5	357.32	615	1.25	11592	3 6 0		
2.3	395.39	817	0.94	11388	4 0 0		
2.0	449.50	924	0.83	11300	4 5 0		
1.7	514.75	869	0.88	11400	5 0 0		
5.6	159.98	353	3.79	29152	C 0 7 3 1 1 6 0 _ M _ - - - . 2 5 C - -	86.5	71
5.3	170.81	377	3.55	29152	1 8 0		
4.6	194.65	404	3.14	29143	2 0 0		
4.0	226.39	465	2.73	29158	2 2 5		
3.6	249.94	545	2.46	29138	2 6 5		
3.3	273.68	595	2.25	29117	2 8 0		
2.8	319.95	651	1.95	29117	3 1 5		
2.6	341.61	693	1.83	29096	3 6 0		
2.4	373.83	806	1.66	29079	4 0 0		
2.1	419.25	900	1.49	29079	4 5 0		
1.8	499.88	997	1.26	29048	5 0 0		
1.6	547.35	1087	1.16	29018	5 6 0		
1.2	747.66	1473	0.86	28940	8 0 0		
1.6	547.09	1183	2.29	41656	C 0 8 4 1 5 6 0 _ M _ - - - . 2 5 C - -	143.5	71
1.4	636.31	1374	1.98	41656	6 3 0		
1.3	711.92	1534	1.77	41656	7 1 0		
1.2	758.79	1635	1.66	41656	8 0 0		
1.0	899.27	1933	1.40	41656	9 0 0		
0.94	960.14	2061	1.32	41656	1 0 C		
0.83	1083.79	2318	1.23	41656	1 1 C		
0.76	1191.45	2546	1.07	41656	1 2 C		
0.64	1404.96	2989	0.91	41656	1 4 C		
0.59	1532.14	3243	1.01	41545	1 6 C		
0.47	1901.25	4010	0.82	41545	1 8 C		
1.6	558.41	1233	3.88	53383	C 0 9 4 1 5 6 0 _ M _ - - - . 2 5 C - -	211.5	71
1.4	649.47	1432	3.34	53383	6 3 0		
1.2	726.65	1598	2.99	53383	7 1 0		
1.2	774.48	1704	2.80	53383	8 0 0		
0.98	917.87	2015	2.37	53383	9 0 0		
0.92	980.00	2149	2.22	53383	1 0 C		
0.83	1088.78	2379	2.02	53383	1 1 C		
0.74	1216.09	2656	1.80	53383	1 2 C		
0.63	1434.02	3120	1.53	53383	1 4 C		
0.59	1537.95	3321	1.48	53383	1 6 C		
0.47	1908.45	4108	1.20	53383	1 8 C		
0.43	2106.88	4525	1.09	53383	2 0 C		
0.40	2250.46	4828	1.02	53383	2 2 C		
0.36	2484.44	5319	0.93	53383	2 5 C		
0.33	2720.42	5813	0.85	53383	2 8 C		
163	8.59	18	4.49	2852	C 0 3 2 1 8 . 0 _ M _ - - - . 3 7 A - -	15.5	71
121	11.61	24	3.63	2850	1 1 .		
106	13.20	27	3.31	2849	1 2 .		
94	14.95	30	3.03	2849	1 4 .		
86	16.36	30	2.90	2847	1 6 .		
73	19.12	39	2.54	2844	1 8 .		
68	20.61	41	2.41	2844	2 0 .		
63	22.11	39	2.37	2844	2 2 .		
56	25.14	45	2.17	2840	2 5 .		
49	28.48	50	2.00	2840	2 8 .		
42	33.71	67	1.68	2826	3 2 .		
38	36.43	63	1.68	2826	3 6 .		

0.37 kW
4 POLE

NOTE:
Other output speeds are available using 2 & 8 pole motors. Please contact our Application Engineers

SERIES C SELECTION TABLE GEARED MOTORS

0.37 kW

4 POLE

N2 RPM	i	M2 Nm	Fm	N	Unit Designation	kg	
Output Speed	Ratio	Output Torque	Service Factor	Overhung Load	Column Entry 1 - 20 Spaces to be filled when entering order	Weight of Base Mount unit	Motor Size
36	39.26	68	1.60	2826	C 0 3 2 1 4 0 . _ M _ _ _ . . 3 7 A - -	15.5	71
31	45.50	90	1.35	2815	4 5 .		
26	53.31	104	1.21	2805	5 0 .		
25	56.19	96	1.25	2815	5 6 .		
22	64.21	108	1.14	2799	6 3 .		
19	74.55	143	0.99	2780	7 1 .		
17	82.83	159	0.92	2780	8 0 .		
16	86.67	143	0.97	2780	9 0 .		
63	22.11	41	3.78	5286	C 0 4 2 1 2 2 . _ M _ _ _ . . 3 7 A - -	18.5	71
56	25.14	46	3.47	5284	2 5 .		
49	28.48	52	3.21	5284	2 8 .		
42	33.71	68	2.82	5280	3 2 .		
38	36.43	65	2.69	5282	3 6 .		
36	39.26	70	2.55	5282	4 0 .		
31	45.50	91	2.26	5282	4 5 .		
26	53.31	105	1.97	5274	5 0 .		
25	56.19	98	2.00	5278	5 6 .		
22	64.21	110	1.82	5274	6 3 .		
19	74.55	145	1.41	5266	7 1 .		
17	82.83	161	1.19	5266	8 0 .		
16	86.67	146	1.54	5280	9 0 .		
14	101.54	169	1.38	5270	1 0 0		
10	142.00	232	1.09	5250	1 4 0		
8.9	157.78	255	1.00	5240	1 6 0		
13	105.36	200	1.02	5255	C 0 4 3 1 1 0 0 _ M _ _ _ . . 3 7 A - -	21.5	71
12	120.39	228	0.89	5249	1 1 8		
11	130.10	210	1.14	5255	1 3 2		
10	140.21	225	1.09	5250	1 5 0		
7.0	200.68	316	0.87	5230	2 0 0		
19	73.37	147	2.59	7434	C 0 5 2 1 7 1 . _ M _ _ _ . . 3 7 A - -	21.5	71
17	82.67	165	2.33	7432	8 0 .		
15	90.67	159	3.00	7432	9 0 .		
14	98.57	171	2.82	7429	1 0 0		
13	109.07	215	1.82	7432	1 1 2		
11	124.00	243	1.58	7434	1 2 5		
10	142.00	240	2.00	7434	1 4 0		
8.8	160.00	268	1.79	7424	1 6 0		
6.6	211.11	349	1.38	7412	2 1 2		
5.8	240.00	392	1.23	7430	2 5 0		
13	103.90	204	1.96	7427	C 0 5 3 1 1 0 0 _ M _ _ _ . . 3 7 A - -	25.5	71
12	118.73	232	1.72	7422	1 1 8		
11	130.38	219	2.19	7424	1 3 2		
10	140.51	235	2.05	7422	1 5 0		
8.7	160.26	309	1.28	7416	1 6 0		
7.5	187.76	360	1.09	7416	1 8 0		
7.0	201.10	329	1.46	7422	2 0 0		
6.1	229.81	374	1.29	7416	2 2 5		
4.5	310.18	496	0.97	7410	3 1 5		
3.9	363.40	577	0.84	7390	3 6 0		
17	80.94	171	3.55	11909	C 0 6 2 1 8 0 . _ M _ _ _ . . 3 7 A - -	34.5	71
13	110.57	230	2.74	11797	1 1 2		
11	124.00	257	2.06	11780	1 2 5		
10	143.08	257	2.97	11780	1 4 0		
8.9	156.67	279	2.74	11780	1 6 0		
6.5	214.00	373	2.05	11741	2 1 2		
5.8	240.00	415	1.84	11701	2 5 0		
8.2	169.81	346	2.21	11741	C 0 6 3 1 1 6 0 _ M _ _ _ . . 3 7 A -	39.5	71
7.6	184.62	375	2.04	11701	1 8 0		
5.3	265.95	533	1.44	11609	2 6 5		
4.7	299.67	599	1.28	11500	2 8 0		
4.3	328.67	553	1.38	11600	3 1 5		
3.9	357.32	599	1.28	11600	3 6 0		
3.5	395.39	784	0.98	11400	4 0 0		
8.8	159.98	340	3.94	29139	C 0 7 3 1 1 6 0 _ M _ _ _ . . 3 7 A - -	86.5	71
8.2	170.81	361	3.71	29145	1 8 0		
7.2	194.65	389	3.05	29145	2 0 0		
6.2	226.39	449	2.71	29127	2 2 5		
5.6	249.94	523	2.56	29109	2 6 5		
5.1	273.68	572	2.34	29091	2 8 0		
4.4	319.95	624	2.03	26917	3 1 5		
4.1	341.61	665	1.91	24796	3 6 0		
3.7	373.83	773	1.73	23910	4 0 0		
3.3	419.25	864	1.55	29041	4 5 0		
2.8	499.88	963	1.32	29001	5 0 0		
2.6	547.35	1051	1.21	29001	5 6 0		
1.9	747.66	1411	0.89	28909	8 0 0		
2.6	547.09	1125	2.41	41656	C 0 8 4 1 5 6 0 _ M _ _ _ . . 3 7 A - -	143.5	71
2.2	636.31	1307	2.08	41656	6 3 0		
2.0	711.92	1460	1.86	41656	7 1 0		
1.8	758.79	1557	1.74	41656	8 0 0		

NOTE:

Other output speeds are available using 2 & 8 pole motors. Please contact our Application Engineers

SERIES C SELECTION TABLE GEARED MOTORS

0.37 kW

4 POLE

0.37 kW

6 POLE

NOTE:

Other output speeds are available using 2 & 8 pole motors. Please contact our Application Engineers

N2 RPM	i	M2 Nm	Fm	N	Unit Designation	kg			
Output Speed	Ratio	Output Torque	Service Factor	Overhung Load	Column Entry 1 - 20 Spaces to be filled when entering order	Weight of Base Mount unit	Motor Size		
1.6	899.27	1842	1.47	41656	C 0 8 4 1 9 0 0 _ M _ _ _ . 3 7 A - -	143.5	71		
1.5	960.14	1966	1.38	41656	1 0 C				
1.3	1083.79	2210	1.29	41656	1 1 C				
1.2	1191.45	2432	1.12	41656	1 2 C				
0.99	1404.96	2860	0.95	41656	1 4 C				
0.91	1532.14	3086	1.06	41545	1 6 C				
0.74	1901.25	3822	0.86	41545	1 8 C				
0.67	2088.45	4183	0.80	41545	2 0 C				
2.2	649.47	1363	3.51	53383	C 0 9 4 1 6 3 0 _ M _ _ _ . 3 7 A - -			211.5	71
1.9	726.65	1522	3.14	53383	7 1 0				
1.8	774.48	1624	2.94	53383	8 0 0				
1.5	917.87	1921	2.49	53383	9 0 0				
1.4	980.00	2050	2.33	53383	1 0 C				
1.3	1088.78	2268	2.12	53383	1 1 C				
1.2	1216.09	2536	1.88	53383	1 2 C				
0.98	1434.02	2983	1.60	53383	1 4 C				
0.91	1537.95	3163	1.56	53383	1 6 C				
0.73	1908.45	3916	1.26	53383	1 8 C				
0.66	2106.88	4313	1.15	53383	2 0 C				
0.62	2250.46	4608	1.07	53383	2 2 C				
0.56	2484.44	5075	0.98	53383	2 5 C				
0.51	2720.42	5549	0.89	53383	2 8 C				
107	8.59	27	3.26	2849	C 0 3 2 1 8 . 0 _ M _ _ _ . 3 7 C - -	19.5	80A		
79	11.61	36	2.67	2845	1 1 .				
70	13.20	41	2.41	2843	1 2 .				
62	14.95	46	2.21	2841	1 4 .				
56	16.36	44	2.15	2842	1 6 .				
48	19.12	58	1.84	2829	1 8 .				
45	20.61	62	1.75	2827	2 0 .				
42	22.11	59	1.75	2829	2 2 .				
37	25.14	66	1.60	2826	2 5 .				
32	28.48	75	1.47	2822	2 8 .				
27	33.71	101	1.23	2810	3 2 .				
25	36.43	94	1.24	2814	3 6 .				
23	39.26	102	1.18	2810	4 0 .				
20	45.50	134	1.02	2787	4 5 .				
17	53.31	156	0.92	2771	5 0 .				
16	56.19	142	0.92	2787	5 6 .				
14	64.21	161	0.84	2771	6 3 .				
62	14.95	47	3.68	5283	C 0 4 2 1 1 4 . _ M _ _ _ . 3 7 C - -			22.5	80A
56	16.36	45	3.44	5283	1 6 .				
48	19.12	59	3.06	5282	1 8 .				
45	20.61	63	2.93	5280	2 0 .				
42	22.11	60	2.80	5280	2 2 .				
37	25.14	68	2.55	5280	2 5 .				
32	28.48	77	2.35	5279	2 8 .				
27	33.71	102	2.04	5273	3 2 .				
25	36.43	97	1.98	5277	3 6 .				
23	39.26	104	1.88	5274	4 0 .				
20	45.50	136	1.52	5270	4 5 .				
17	53.31	159	1.30	5266	5 0 .				
16	56.19	145	1.47	5270	5 6 .				
14	64.21	164	1.34	5262	6 3 .				
12	74.55	218	0.93	5255	7 1 .				
11	86.67	217	1.13	5250	9 0 .				
9.1	101.54	252	1.01	5240	1 0 0				
6.5	142.00	345	0.81	5220	1 4 0				
7.1	130.10	313	0.87	5226	C 0 4 3 1 1 3 2 _ M _ _ _ . 3 7 C - -	25.5	80A		
6.6	140.21	337	0.82	5220	1 5 0				
28	32.55	101	3.81	7440	C 0 5 2 1 3 2 . _ M _ _ _ . 3 7 C - -	25.5	80A		
23	40.74	111	3.76	7440	4 0 .				
20	46.84	143	2.82	7440	4 5 .				
18	50.93	156	2.59	7440	5 0 .				
17	55.45	149	3.00	7440	5 6 .				
15	63.00	167	2.75	7440	6 3 .				
13	73.37	220	1.81	7424	7 1 .				
11	82.67	247	1.61	7422	8 0 .				
10	90.67	235	2.05	7422	9 0 .				
9.3	98.57	254	1.90	7419	1 0 0				
8.4	109.07	324	1.20	7416	1 1 2				
7.4	124.00	365	1.04	7416	1 2 5				
6.5	142.00	357	1.35	7416	1 4 0				
5.8	160.00	399	1.21	7404	1 6 0				
4.4	211.11	519	0.93	4487	2 1 2				
3.8	240.00	585	0.82	7390	2 5 0				

SERIES C SELECTION TABLE GEARED MOTORS

0.37 kW

6 POLE

N2 RPM	i	M2 Nm	Fm	N	Unit Designation	kg	
Output Speed	Ratio	Output Torque	Service Factor	Overhung Load	Column Entry 1 - 20 Spaces to be filled when entering order	Weight of Base Mount unit	Motor Size
8.9	103.90	306	1.29	5761	C 0 5 3 1 1 0 0 _ M _ _ _ _ . 3 7 C - -	29.5	80A
7.7	118.73	348	1.13	5542	1 1 8		
7.1	130.38	327	1.47	5542	1 3 2		
6.5	140.51	350	1.38	5542	1 5 0		
5.7	160.26	464	0.84	4487	1 6 0		
4.6	201.10	492	0.98	7399	2 0 0		
4.0	229.81	558	0.86	7387	2 2 5		
12	73.92	236	3.24	11791	C 0 6 2 1 7 1 . _ M _ _ _ _ . 3 7 C - -	37.5	80A
11	80.94	256	2.69	11773	8 0 .		
10	91.58	252	3.03	11873	9 0 .		
9.4	97.78	268	2.85	11773	1 0 0		
8.3	110.57	346	2.06	11721	1 1 2		
7.4	124.00	386	1.35	11701	1 2 5		
6.4	143.08	381	2.01	11741	1 4 0		
5.9	156.67	415	1.84	11701	1 6 0		
4.3	214.00	554	1.38	11622	2 1 2		
3.8	240.00	617	1.24	11582	2 5 0		
8.9	103.86	324	2.36	11800	C 0 6 3 1 1 0 0 _ M _ _ _ _ . 3 7 C - -	43.5	80A
7.8	117.99	366	2.09	11700	1 1 8		
7.1	130.00	345	2.22	11800	1 3 2		
6.2	147.69	389	1.97	11700	1 5 0		
5.4	169.81	521	1.47	11622	1 6 0		
5.0	184.62	565	1.35	11582	1 8 0		
4.6	201.02	519	1.47	11600	2 0 0		
4.0	228.38	585	1.31	11600	2 2 5		
3.5	265.95	803	0.95	11393	2 6 5		
3.1	299.67	901	0.85	11300	2 8 0		
2.8	328.67	823	0.93	11400	3 1 5		
2.6	357.32	890	0.86	11400	3 6 0		
9.2	99.79	312	3.65	29200	C 0 7 2 1 1 0 0 _ M _ _ _ _ . 3 7 C - -	80.5	80A
8.8	104.32	339	3.24	29200	1 1 2		
7.9	115.92	375	2.93	29200	1 2 5		
6.7	138.00	425	2.82	29200	1 4 0		
6.1	151.12	461	2.64	29200	1 6 0		
4.4	208.65	627	2.03	29200	2 1 2		
4.0	231.83	693	1.83	29200	2 5 0		
8.1	113.20	366	3.65	29139	C 0 7 3 1 1 1 8 _ M _ _ _ _ . 3 7 C - -	89.5	80A
7.4	125.04	379	3.11	29200	1 3 2		
6.5	141.75	432	2.80	29200	1 5 0		
5.8	159.98	512	2.62	29109	1 6 0		
5.4	170.81	546	2.45	29109	1 8 0		
4.7	194.65	585	2.17	29091	2 0 0		
4.1	226.39	673	1.89	29120	2 2 5		
3.7	249.94	789	1.70	29080	2 6 5		
3.4	273.68	862	1.55	29041	2 8 0		
2.9	319.95	942	1.35	29041	3 1 5		
2.7	341.61	1004	1.26	29001	3 6 0		
2.5	373.83	1167	1.15	28967	4 0 0		
2.2	419.25	1303	1.03	28967	4 5 0		
1.8	499.88	1443	0.87	28909	5 0 0		
1.7	547.35	1574	0.80	28851	5 6 0		
3.9	235.77	712	3.68	41900	C 0 8 2 1 2 5 0 _ M _ _ _ _ . 3 7 C - -	130.5	80A
1.7	547.09	1713	1.58	41656	C 0 8 4 1 5 6 0 _ M _ _ _ _ . 3 7 C - -	146.5	80A
1.4	636.31	1990	1.36	41656	6 3 0		
1.3	711.92	2221	1.22	41656	7 1 0		
1.2	758.79	2368	1.15	41656	8 0 0		
1.0	899.27	2798	0.97	41656	9 0 0		
0.96	960.14	2984	0.91	41656	1 0 C		
0.85	1083.79	3357	0.85	41656	1 1 C		
1.6	558.41	1785	2.68	53383	C 0 9 4 1 5 6 0 _ M _ _ _ _ . 3 7 C - -	214.5	80A
1.4	649.47	2073	2.31	53383	6 3 0		
1.3	726.65	2314	2.07	53383	7 1 0		
1.2	774.48	2468	1.94	53383	8 0 0		
1.0	917.87	2917	1.64	53383	9 0 0		
0.94	980.00	3112	1.54	53383	1 0 C		
0.84	1088.78	3445	1.40	53383	1 1 C		
0.76	1216.09	3846	1.24	53383	1 2 C		
0.64	1434.02	4518	1.06	53383	1 4 C		
0.60	1537.95	4809	1.02	53383	1 6 C		
0.48	1908.45	5947	0.83	53383	1 8 C		

NOTE:

Other output speeds are available using 2 & 8 pole motors. Please contact our Application Engineers

SERIES C SELECTION TABLE GEARED MOTORS

0.55 kW
4 POLE

N2 RPM	i	M2 Nm	Fm	N	Unit Designation	kg	
Output Speed	Ratio	Output Torque	Service Factor	Overhung Load	Column Entry 1 - 20 Spaces to be filled when entering order	Weight of Base Mount unit	Motor Size
165	8.59	26	3.06	2847	C 0 3 2 1 8 . 0 _ M _ _ _ . 5 5 A - -	19.5	80A
122	11.61	35	2.47	2844	1 1 .		
108	13.20	39	2.26	2841	1 2 .		
95	14.95	45	2.07	2841	1 4 .		
87	16.36	44	1.98	2838	1 6 .		
74	19.12	57	1.73	2833	1 8 .		
69	20.61	61	1.64	2833	2 0 .		
64	22.11	58	1.62	2833	2 2 .		
56	25.14	66	1.48	2825	2 5 .		
50	28.48	74	1.36	2825	2 8 .		
42	33.71	98	1.15	2809	3 2 .		
39	36.43	93	1.15	2809	3 6 .		
36	39.26	100	1.09	2809	4 0 .		
31	45.50	132	0.92	2790	4 5 .		
27	53.31	153	0.83	2780	5 0 .		
25	56.19	140	0.85	2790	5 6 .		
108	13.20	40	3.76	5285	C 0 4 2 1 1 2 . _ M _ _ _ . 5 5 A - -	22.5	80A
95	14.95	46	3.45	5283	1 4 .		
87	16.36	45	3.17	5283	1 6 .		
74	19.12	58	2.88	5283	1 8 .		
69	20.61	62	2.74	5283	2 0 .		
64	22.11	60	2.58	5283	2 2 .		
56	25.14	67	2.37	5280	2 5 .		
50	28.48	76	2.19	5280	2 8 .		
42	33.71	99	1.92	5274	3 2 .		
39	36.43	95	1.83	5276	3 6 .		
36	39.26	102	1.74	5276	4 0 .		
31	45.50	133	1.54	5276	4 5 .		
27	53.31	155	1.35	5262	5 0 .		
25	56.19	143	1.36	5269	5 6 .		
22	64.21	162	1.24	5262	6 3 .		
19	74.55	213	0.97	5250	7 1 .		
17	82.83	236	0.81	5250	8 0 .		
44	32.55	99	3.44	7440	C 0 5 2 1 3 2 . _ M _ _ _ . 5 5 A - -	25.5	80A
40	35.86	98	3.85	7440	3 6 .		
35	40.74	110	3.51	7440	4 0 .		
30	46.84	141	2.71	7440	4 5 .		
28	50.93	152	2.56	7440	5 0 .		
26	55.45	147	2.81	7440	5 6 .		
23	63.00	165	2.58	7440	6 3 .		
19	73.37	215	1.76	7431	7 1 .		
17	82.67	241	1.59	7426	8 0 .		
16	90.67	233	2.05	7426	9 0 .		
14	98.57	250	1.92	7422	1 0 0 .		
13	109.07	316	1.24	7426	1 1 2 .		
11	124.00	357	1.08	7430	1 2 5 .		
10	142.00	352	1.37	7430	1 4 0 .		
8.9	160.00	394	1.22	7412	1 6 0 .		
6.7	211.11	511	0.94	7392	2 1 2 .		
14	103.90	299	1.34	7418	C 0 5 3 1 1 0 0 _ M _ _ _ . 5 5 A - -	29.5	80A
12	118.73	340	1.17	7409	1 1 8 .		
11	130.38	321	1.50	7413	1 3 2 .		
10	140.51	345	1.40	7409	1 5 0 .		
8.9	160.26	453	0.87	7399	1 6 0 .		
7.1	201.10	483	1.00	7410	2 0 0 .		
6.2	229.81	549	0.88	7400	2 2 5 .		
22	64.80	180	3.99	11896	C 0 6 2 1 6 3 . _ M _ _ _ . 5 5 A - -	37.5	80A
19	73.92	230	3.31	11844	7 1 .		
18	80.94	251	2.42	11844	8 0 .		
16	91.58	250	3.06	11844	9 0 .		
15	97.78	265	2.88	11844	1 0 0 .		
13	110.57	338	1.87	11724	1 1 2 .		
11	124.00	376	1.41	11695	1 2 5 .		
10	143.08	377	2.03	11695	1 4 0 .		
9.1	156.67	409	1.87	11695	1 6 0 .		
6.6	214.00	548	1.40	11626	2 1 2 .		
5.9	240.00	609	1.26	11558	2 5 0 .		
14	103.86	316	2.42	11800	C 0 6 3 1 1 0 0 _ M _ _ _ . 5 5 A - -	43.5	80A
12	117.99	358	2.14	11700	1 1 8 .		
11	130.00	341	2.24	11800	1 3 2 .		
10	147.69	384	1.99	11700	1 5 0 .		
8.4	169.81	508	1.51	11626	1 6 0 .		
7.7	184.62	550	1.39	11558	1 8 0 .		
7.1	201.02	512	1.50	11600	2 0 0 .		
6.2	228.38	577	1.33	11600	2 2 5 .		
5.3	265.95	782	0.98	11400	2 6 5 .		
19	75.56	243	3.85	29200	C 0 7 2 1 8 0 . _ M _ _ _ . 5 5 A - -	80.5	80A
16	88.26	271	3.79	29200	9 0 .		
14	99.79	303	3.45	29200	1 0 0 .		
14	104.32	330	2.94	29200	1 1 2 .		
12	115.92	366	2.64	29200	1 2 5 .		
10	138.00	413	2.71	29200	1 4 0 .		
9.4	151.12	454	2.51	29200	1 6 0 .		

NOTE:
Other output speeds are available using 2 & 8 pole motors. Please contact our Application Engineers

SERIES C

SELECTION TABLE

GEARED MOTORS

0.55 kW

4 POLE

N2 RPM	i	M2 Nm	Fm	N	Unit Designation	kg	
Output Speed	Ratio	Output Torque	Service Factor	Overhung Load	Column Entry 1 - 20 Spaces to be filled when entering order	Weight of Base Mount unit	Motor Size
6.8	208.65	612	1.96	29200	C 0 7 2 1 2 1 2 _ M _ _ _ . 5 5 A -	80.5	80A
6.1	231.83	678	1.80	29200	2 5 0		
13	113.20	356	3.76	29125	C 0 7 3 1 1 1 8 _ M _ _ _ . 5 5 A -	89.5	80A
11	125.04	372	2.96	29200	1 3 2		
10	141.75	416	2.69	29200	1 5 0		
8.9	159.98	498	2.69	29096	1 6 0		
8.3	170.81	529	2.53	29106	1 8 0		
7.3	194.65	571	2.08	29106	2 0 0		
6.3	226.39	658	1.85	29075	2 2 5		
5.7	249.94	767	1.74	29044	2 6 5		
5.2	273.68	838	1.60	29013	2 8 0		
4.4	319.95	915	1.39	25273	3 1 5		
4.2	341.61	975	1.30	21625	3 6 0		
3.8	373.83	1133	1.18	20101	4 0 0		
3.4	419.25	1266	1.06	28926	4 5 0		
2.8	499.88	1412	0.90	28858	5 0 0		
2.6	547.35	1540	0.82	28858	5 6 0		
6.0	235.77	699	3.61	41900	C 0 8 2 1 2 5 0 _ M _ _ _ . 5 5 A -		
2.6	547.09	1649	1.65	41656	C 0 8 4 1 5 6 0 _ M _ _ _ . 5 5 A -		
2.2	636.31	1916	1.42	41656	6 3 0	214.5	80A
2.0	711.92	2140	1.27	41656	7 1 0		
1.9	758.79	2282	1.19	41656	8 0 0		
1.6	899.27	2700	1.01	41656	9 0 0		
1.5	960.14	2881	0.94	41656	1 0 C		
1.3	1083.79	3239	0.88	41656	1 1 C		
2.5	558.41	1719	2.78	53383	C 0 9 4 1 5 6 0 _ M _ _ _ . 5 5 A -		
2.2	649.47	1998	2.39	53383	6 3 0		
2.0	726.65	2231	2.14	53383	7 1 0		
1.8	774.48	2380	2.01	53383	8 0 0		
1.5	917.87	2816	1.70	53383	9 0 0		
1.4	980.00	3004	1.59	53383	1 0 C		
1.3	1088.78	3325	1.45	53383	1 1 C		
1.2	1216.09	3717	1.29	53383	1 2 C		
0.99	1434.02	4371	1.09	53383	1 4 C		
0.92	1537.95	4636	1.06	53383	1 6 C		
0.74	1908.45	5740	0.86	53383	1 8 C		

0.55 kW

6 POLE

107	8.59	40	2.20	2841	C 0 3 2 1 8 . 0 _ M _ _ _ . 5 5 C -	21	80B		
79	11.61	53	1.79	2835	1 1 .				
70	13.20	61	1.62	2831	1 2 .				
62	14.95	68	1.49	2828	1 4 .				
56	16.36	66	1.44	2829	1 6 .				
48	19.12	87	1.24	2814	1 8 .				
45	20.61	93	1.18	2810	2 0 .				
42	22.11	88	1.18	2814	2 2 .				
37	25.14	99	1.08	2809	2 5 .				
32	28.48	112	0.99	2802	2 8 .				
27	33.71	150	0.83	2781	3 2 .				
25	36.43	140	0.83	2788	3 6 .				
107	8.59	41	3.64	5285	C 0 4 2 1 8 . 0 _ M _ _ _ . 5 5 C -			24	80B
79	11.61	55	2.96	5281	1 1 .				
70	13.20	61	2.70	5279	1 2 .				
62	14.95	69	2.47	5279	1 4 .				
56	16.36	68	2.32	5279	1 6 .				
48	19.12	89	2.06	5277	1 8 .				
45	20.61	94	1.97	5274	2 0 .				
42	22.11	90	1.88	5274	2 2 .				
37	25.14	101	1.72	5274	2 5 .				
32	28.48	114	1.58	5271	2 8 .				
27	33.71	152	1.37	5261	3 2 .				
25	36.43	144	1.33	5268	3 6 .				
23	39.26	154	1.27	5263	4 0 .				
20	45.50	203	1.02	5255	4 5 .				
17	53.31	236	0.87	5249	5 0 .				
16	56.19	215	0.99	5255	5 6 .				
14	64.21	244	0.90	5242	6 3 .				

NOTE:

Other output speeds are available using 2 & 8 pole motors. Please contact our Application Engineers

50	18.53	87	3.69	7439	C 0 5 2 1 1 8 . _ M _ _ _ . 5 5 C -	27	80B
44	21.05	98	3.42	7438	2 0 .		
41	22.56	95	3.89	7439	2 2 .		
37	24.86	104	3.62	7438	2 5 .		
33	28.24	118	3.29	7437	2 8 .		
28	32.55	151	2.56	7435	3 2 .		
26	35.86	147	2.77	7435	3 6 .		

SERIES C SELECTION TABLE GEARED MOTORS

0.55 kW

6 POLE

N2 RPM	i	M2 Nm	Fm	N	Unit Designation	kg	
Output Speed	Ratio	Output Torque	Service Factor	Overhung Load	Column Entry 1 - 20 Spaces to be filled when entering order	Weight of Base Mount unit	Motor Size
23	40.74	166	2.53	7434	C 0 5 2 1 4 0 . _ M _ - _ _ . 5 5 C - -	27	80B
20	46.84	213	1.90	7432	4 5 .		
18	50.93	232	1.74	7430	5 0 .		
17	55.45	222	2.02	7432	5 6 .		
15	63.00	249	1.85	7430	6 3 .		
13	73.37	328	1.22	7413	7 1 .		
11	82.67	367	1.08	7409	8 0 .		
10	90.67	349	1.38	7409	9 0 .		
9.3	98.57	377	1.28	7404	1 0 0		
8.4	109.07	481	0.81	7399	1 1 2		
6.5	142.00	530	0.91	7400	1 4 0		
5.8	160.00	593	0.81	7378	1 6 0		
8.9	103.90	455	0.87	4552	C 0 5 3 1 1 0 0 _ M _ - _ _ . 5 5 C - -	31	80B
7.1	130.38	486	0.99	4175	1 3 2		
6.5	140.51	520	0.93	4175	1 5 0		
19	47.32	228	3.35	11865	C 0 6 2 1 4 5 . _ M _ - _ _ . 5 5 C - -	39	80B
18	50.52	242	3.15	11855	5 0 .		
17	55.71	236	3.19	11855	5 6 .		
14	64.80	271	2.82	11834	6 3 .		
12	73.92	351	2.18	11713	7 1 .		
11	80.94	380	1.81	11681	8 0 .		
10	91.58	375	2.04	11781	9 0 .		
9.4	97.78	399	1.92	11681	1 0 0		
8.3	110.57	515	1.39	11592	1 1 2		
7.4	124.00	573	0.91	11558	1 2 5		
6.4	143.08	567	1.35	11626	1 4 0		
5.9	156.67	617	1.24	11558	1 6 0		
4.3	214.00	824	0.93	11422	2 1 2		
3.8	240.00	917	0.83	11353	2 5 0		
8.9	103.86	482	1.59	11676	C 0 6 3 1 1 0 0 _ M _ - _ _ . 5 5 C - -	45	80B
7.8	117.99	545	1.40	11576	1 1 8		
7.1	130.00	513	1.49	11676	1 3 2		
6.2	147.69	578	1.32	11576	1 5 0		
5.4	169.81	775	0.99	11422	1 6 0		
5.0	184.62	840	0.91	11353	1 8 0		
4.6	201.02	772	0.99	11457	2 0 0		
4.0	228.38	870	0.88	11410	2 2 5		
18	49.90	248	3.85	29180	C 0 7 2 1 5 0 . _ M _ - _ _ . 5 5 C - -	82	80B
17	53.62	254	3.97	29179	5 6 .		
15	61.62	292	3.55	29179	6 3 .		
13	69.00	338	3.10	29172	7 1 .		
12	75.56	370	2.86	29165	8 0 .		
10	88.26	410	2.70	29168	9 0 .		
9.2	99.79	464	2.46	29168	1 0 0		
8.8	104.32	505	2.18	29168	1 1 2		
7.9	115.92	558	1.97	29152	1 2 5		
6.7	138.00	631	1.90	29150	1 4 0		
6.1	151.12	686	1.78	29150	1 6 0		
4.4	208.65	932	1.36	29105	2 1 2		
4.0	231.83	1030	1.23	29057	2 5 0		
9.5	97.33	471	2.84	29117	C 0 7 3 1 1 0 0 _ M _ - _ _ . 5 5 C - -	91	80B
8.1	113.20	545	2.46	29096	1 1 8		
7.4	125.04	564	2.09	29150	1 3 2		
6.5	141.75	642	1.88	29136	1 5 0		
5.8	159.98	761	1.76	29044	1 6 0		
5.4	170.81	812	1.65	29044	1 8 0		
4.7	194.65	870	1.46	29013	2 0 0		
4.1	226.39	1001	1.27	29063	2 2 5		
3.7	249.94	1174	1.14	28995	2 6 5		
3.4	273.68	1281	1.05	28926	2 8 0		
2.9	319.95	1401	0.91	28926	3 1 5		
2.7	341.61	1493	0.85	28858	3 6 0		
6.6	139.29	644	3.85	41880	C 0 8 2 1 1 4 0 _ M _ - _ _ . 5 5 C - -	132	80B
6.0	153.00	705	3.57	41880	1 6 0		
4.5	204.75	931	2.82	41868	2 1 2		
3.9	235.77	1058	2.47	41868	2 5 0		
1.7	547.09	2547	1.07	41656	C 0 8 4 1 5 6 0 _ M _ - _ _ . 5 5 C - -	148	80B
1.4	636.31	2958	0.92	41656	6 3 0		
1.3	711.92	3301	0.82	41656	7 1 0		
1.6	558.41	2654	1.80	53383	C 0 9 4 1 5 6 0 _ M _ - _ _ . 5 5 C - -	216	80B
1.4	649.47	3082	1.55	53383	6 3 0		
1.3	726.65	3441	1.39	53383	7 1 0		
1.2	774.48	3668	1.30	53383	8 0 0		
1.0	917.87	4337	1.10	53383	9 0 0		
0.94	980.00	4626	1.03	53383	1 0 C		
0.84	1088.78	5121	0.94	53383	1 1 C		
0.76	1216.09	5717	0.84	53383	1 2 C		
1.9	495.31	2376	3.57	87299	C 1 0 4 1 5 0 0 _ M _ - _ _ . 5 5 C - -	334	80B
1.7	544.84	2611	3.24	87299	5 6 0		

NOTE:

Other output speeds are available using 2 & 8 pole motors. Please contact our Application Engineers

SERIES C SELECTION TABLE GEARED MOTORS

0.55 kW
6 POLE

0.75 kW
4 POLE

N2 RPM	i	M2 Nm	Fm	N	Unit Designation	kg	
Output Speed	Ratio	Output Torque	Service Factor	Overhung Load	Column Entry 1 - 20 Spaces to be filled when entering order	Weight of Base Mount unit	Motor Size
1.5	626.07	2997	2.83	87299	C 1 0 4 1 6 3 0 _ M _ _ _ . 5 5 C _ _	334	80B
1.3	709.95	3391	2.50	87299	7 1 0		
1.2	783.06	3741	2.27	87299	8 0 0		
1.0	896.77	4277	1.98	87299	9 0 0		
0.91	1013.93	4827	1.76	87299	1 0 C		
0.82	1126.71	5342	1.55	87375	1 1 C		
0.78	1175.54	5582	1.52	87299	1 2 C		
0.66	1402.11	6635	1.28	87299	1 4 C		
0.57	1606.71	7534	1.14	87299	1 6 C		
0.49	1862.80	8716	0.98	87299	1 8 C		
0.43	2146.36	9991	0.86	87299	2 0 C		
0.41	2221.83	10366	0.83	87299	2 2 C		
165	8.59	36	2.24	2841	C 0 3 2 1 8 . 0 _ M _ _ _ . 7 5 A _ _		
122	11.61	48	1.81	2837	1 1 .		
107	13.20	54	1.65	2832	1 2 .		
95	14.95	62	1.51	2832	1 4 .		
86	16.36	60	1.44	2827	1 6 .		
74	19.12	78	1.27	2821	1 8 .		
69	20.61	84	1.20	2821	2 0 .		
64	22.11	80	1.18	2821	2 2 .		
56	25.14	90	1.08	2810	2 5 .		
50	28.48	101	1.00	2810	2 8 .		
42	33.71	134	0.84	2790	3 2 .		
39	36.43	127	0.84	2790	3 6 .		
165	8.59	37	3.70	5287	C 0 4 2 1 8 . 0 _ M _ _ _ . 7 5 A _ _	22.5	80A
122	11.61	49	3.01	5283	1 1 .		
107	13.20	56	2.75	5283	1 2 .		
95	14.95	62	2.52	5280	1 4 .		
86	16.36	62	2.32	5280	1 6 .		
74	19.12	79	2.11	5280	1 8 .		
69	20.61	85	2.00	5280	2 0 .		
64	22.11	82	1.89	5280	2 2 .		
56	25.14	93	1.73	5276	2 5 .		
50	28.48	104	1.60	5276	2 8 .		
42	33.71	136	1.41	5267	3 2 .		
39	36.43	131	1.34	5270	3 6 .		
36	39.26	140	1.27	5270	4 0 .		
31	45.50	182	1.13	5270	4 5 .		
27	53.31	212	0.98	5250	5 0 .		
25	56.19	196	1.00	5260	5 6 .		
22	64.21	222	0.91	5250	6 3 .		
76	18.53	79	3.57	7440	C 0 5 2 1 1 8 . _ M _ _ _ . 7 5 A _ _	25.5	80A
67	21.05	89	3.30	7439	2 0 .		
63	22.56	87	3.94	7439	2 2 .		
57	24.86	95	3.68	7439	2 5 .		
50	28.24	107	3.37	7438	2 8 .		
43	32.55	135	2.51	7437	3 2 .		
39	35.86	134	2.81	7437	3 6 .		
35	40.74	151	2.56	7437	4 0 .		
30	46.84	193	1.98	7437	4 5 .		
28	50.93	208	1.87	7435	5 0 .		
26	55.45	201	2.06	7435	5 6 .		
22	63.00	226	1.89	7433	6 3 .		
19	73.37	295	1.29	7427	7 1 .		
17	82.67	330	1.16	7420	8 0 .		
16	90.67	319	1.50	7420	9 0 .		
14	98.57	343	1.41	7414	1 0 0		
13	109.07	432	0.91	7420	1 1 2		
8.8	160.00	539	0.89	7400	1 6 0		
14	103.90	409	0.98	7407	C 0 5 3 1 1 0 0 _ M _ _ _ . 7 5 A _ _	29.5	80A
12	118.73	465	0.86	7395	1 1 8		
11	130.38	440	1.09	7401	1 3 2		
10	140.51	472	1.02	7395	1 5 0		
30	47.32	205	3.38	11868	C 0 6 2 1 4 5 . _ M _ _ _ . 7 5 A _ _	37.5	80A
28	50.52	218	3.24	11848	5 0 .		
25	55.71	215	3.24	11878	5 6 .		
22	64.80	247	2.91	11848	6 3 .		
19	73.92	314	2.42	11771	7 1 .		
17	80.94	344	1.77	11771	8 0 .		
15	91.58	342	2.24	11771	9 0 .		
14	97.78	363	2.11	11771	1 0 0		
13	110.57	462	1.37	11642	1 1 2		
11	124.00	515	1.03	11600	1 2 5		
10	143.08	516	1.48	11600	1 4 0		

NOTE:
Other output speeds are available using 2 & 8 pole motors. Please contact our Application Engineers

SERIES C SELECTION TABLE GEARED MOTORS

0.75 kW
4 POLE

N2 RPM	i	M2 Nm	Fm	N	Unit Designation	kg			
Output Speed	Ratio	Output Torque	Service Factor	Overhung Load	Column Entry 1 - 20 Spaces to be filled when entering order	Weight of Base Mount unit	Motor Size		
9	156.67	560	1.37	11600	C 0 6 2 1 1 6 0 _ M _ _ _ . 7 5 A - -	37.5	80A		
6.6	214.00	749	1.02	11500	2 1 2				
5.9	240.00	833	0.92	11400	2 5 0				
14	103.86	432	1.77	11690	C 0 6 3 1 1 0 0 _ M _ _ _ . 7 5 A - -	43.5	80A		
12	117.99	490	1.56	11590	1 1 8				
11	130.00	467	1.64	11690	1 3 2				
10	147.69	525	1.46	11627	1 5 0				
8.3	169.81	695	1.10	11500	1 6 0				
7.7	184.62	753	1.02	11400	1 8 0				
7.0	201.02	700	1.09	11500	2 0 0				
6.2	228.38	790	0.97	11400	2 2 5				
28	49.90	222	3.96	29187	C 0 7 2 1 5 0 . _ M _ _ _ . 7 5 A - -			80.5	80A
23	61.62	262	3.70	29182	6 3 .				
21	69.00	304	3.04	29182	7 1 .				
19	75.56	333	2.81	29176	8 0 .				
16	88.26	371	2.77	29175	9 0 .				
14	99.79	415	2.52	29175	1 0 0				
14	104.32	452	2.15	29175	1 1 2				
12	115.92	502	1.93	29163	1 2 5				
10	138.00	566	1.98	29157	1 4 0				
9.4	151.12	621	1.83	29157	1 6 0				
6.8	208.65	838	1.43	29127	2 1 2				
6.1	231.83	928	1.31	29090	2 5 0				
15	97.33	422	3.17	29134	C 0 7 3 1 1 0 0 _ M _ _ _ . 7 5 A - -	89.5	80A		
13	113.20	488	2.75	29090	1 1 8				
11	125.04	509	2.16	29159	1 3 2				
10	141.75	570	1.96	29163	1 5 0				
8.8	159.98	682	1.96	29048	1 6 0				
8.3	170.81	725	1.85	29063	1 8 0				
7.3	194.65	781	1.52	29063	2 0 0				
6.3	226.39	901	1.35	29017	2 2 5				
5.7	249.94	1050	1.28	28971	2 6 5				
5.2	273.68	1148	1.17	28926	2 8 0				
4.4	319.95	1252	1.01	23447	3 1 5				
4.1	341.61	1335	0.95	18101	3 6 0				
3.8	373.83	1550	0.86	15869	4 0 0				
10	139.29	578	3.99	41882	C 0 8 2 1 1 4 0 _ M _ _ _ . 7 5 A - -			130.5	80A
9.2	153.00	633	3.71	41883	1 6 0				
6.9	204.75	836	2.95	41867	2 1 2				
6.0	235.77	957	2.64	41875	2 5 0				
2.6	547.09	2256	1.20	41656	C 0 8 4 1 5 6 0 _ M _ _ _ . 7 5 A - -	146.5	80A		
2.2	636.31	2622	1.04	41656	6 3 0				
2.0	711.92	2929	0.93	41656	7 1 0				
1.9	758.79	3123	0.87	41656	8 0 0				
2.5	558.41	2353	2.03	53383	C 0 9 4 1 5 6 0 _ M _ _ _ . 7 5 A - -	214.5	80A		
2.2	649.47	2734	1.75	53383	6 3 0				
1.9	726.65	3054	1.57	53383	7 1 0				
1.8	774.48	3257	1.47	53383	8 0 0				
1.5	917.87	3853	1.24	53383	9 0 0				
1.4	980.00	4111	1.16	53383	1 0 C				
1.3	1088.78	4550	1.06	53383	1 1 C				
1.2	1216.09	5087	0.94	53383	1 2 C				
2.6	544.84	2314	3.66	87299	C 1 0 4 1 5 6 0 _ M _ _ _ . 7 5 A - -			332.5	80A
2.3	626.07	2657	3.19	87299	6 3 0				
2.0	709.95	3008	2.82	87299	7 1 0				
1.8	783.06	3319	2.55	87299	8 0 0				
1.6	896.77	3797	2.23	87299	9 0 0				
1.4	1013.93	4288	1.98	87299	1 0 C				
1.3	1126.71	4744	1.75	87375	1 1 C				
1.2	1175.54	4962	1.71	87299	1 2 C				
1.0	1402.11	5904	1.44	87299	1 4 C				
0.88	1606.71	6682	1.28	87299	1 6 C				
0.76	1862.80	7737	1.11	87299	1 8 C				
0.66	2146.36	8864	0.97	87299	2 0 C				
0.64	2221.83	9211	0.93	87299	2 2 C				
0.55	2560.05	10553	0.81	87299	2 5 C				

NOTE:

Other output speeds are available using 2 & 8 pole motors. Please contact our Application Engineers

SERIES C

SELECTION TABLE

GEARED MOTORS

0.75 kW

6 POLE

N2 RPM	i	M2 Nm	Fm	N	Unit Designation	kg	
Output Speed	Ratio	Output Torque	Service Factor	Overhung Load	Column Entry 1 - 20 Spaces to be filled when entering order	Weight of Base Mount unit	Motor Size
107	8.59	55	1.61	2832	C 0 3 2 1 8 . 0 _ M _ _ _ . 7 5 C - -	24.5	90S
79	11.61	73	1.32	2823	1 1 .		
70	13.20	83	1.19	2818	1 2 .		
62	14.95	93	1.09	2814	1 4 .		
56	16.36	90	1.06	2815	1 6 .		
48	19.12	118	0.91	2798	C 0 3 2 1 1 8 . _ M _ _ _ . 7 5 C - -	24.5	90S
45	20.61	127	0.86	2792	2 0 .		
42	22.11	120	0.87	2798	2 2 .		
107	8.59	56	2.67	5283	C 0 4 2 1 8 . 0 _ M _ _ _ . 7 5 C - -	26.5	90S
79	11.61	75	2.17	5277	1 1 .		
70	13.20	84	1.98	5274	1 2 .		
62	14.95	95	1.81	5274	1 4 .		
56	16.36	92	1.70	5274	1 6 .		
48	19.12	121	1.51	5271	1 8 .		
45	20.61	129	1.44	5267	2 0 .		
42	22.11	123	1.38	5267	2 2 .		
37	25.14	138	1.26	5267	2 5 .		
32	28.48	156	1.16	5262	2 8 .		
27	33.71	207	1.01	5248	3 2 .		
25	36.43	196	0.97	5257	3 6 .		
23	39.26	210	0.93	5251	4 0 .		
79	11.66	76	3.60	7440	C 0 5 2 1 1 1 . _ M _ _ _ . 7 5 C - -	30.5	90S
72	12.85	84	3.40	7440	1 2 .		
63	14.59	95	3.14	7440	1 4 .		
57	16.09	95	3.65	7440	1 6 .		
50	18.53	119	2.71	7437	1 8 .		
44	21.05	134	2.50	7435	2 0 .		
41	22.56	130	2.85	7437	2 2 .		
37	24.86	142	2.66	7435	2 5 .		
33	28.24	161	2.41	7433	2 8 .		
28	32.55	206	1.88	7429	3 2 .		
26	35.86	201	2.03	7429	3 6 .		
23	40.74	226	1.85	7427	4 0 .		
20	46.84	291	1.39	7423	4 5 .		
18	50.93	316	1.28	7419	5 0 .		
17	55.45	302	1.48	7423	5 6 .		
15	63.00	340	1.35	7419	6 3 .		
13	73.37	447	0.89	7401	7 1 .		
10	90.67	476	1.01	7395	9 0 .		
9.3	98.57	515	0.94	7388	1 0 0		
33	28.18	170	3.82	11937	C 0 6 2 1 2 8 . _ M _ _ _ . 7 5 C - -	42.5	90S
27	33.48	223	3.17	11816	3 2 .		
26	35.79	213	3.22	11826	3 6 .		
23	40.57	239	2.94	11813	4 0 .		
19	47.32	312	2.45	11803	4 5 .		
18	50.52	331	2.31	11787	5 0 .		
17	55.71	322	2.34	11787	5 6 .		
14	64.80	370	2.07	11757	6 3 .		
12	73.92	479	1.60	11626	7 1 .		
11	80.94	519	1.33	11580	8 0 .		
10	91.58	512	1.49	11680	9 0 .		
9.4	97.78	544	1.41	11580	1 0 0		
8.3	110.57	703	1.02	11450	1 1 2		
6.4	143.08	773	0.99	11500	1 4 0		
5.9	156.67	841	0.91	11400	1 6 0		
8.9	103.86	658	1.16	11539	C 0 6 3 1 1 0 0 _ M _ _ _ . 7 5 C - -	47.5	90S
7.8	117.99	743	1.03	11439	1 1 8		
7.1	130.00	700	1.09	11539	1 3 2		
6.2	147.69	788	0.97	11439	1 5 0		
21	44.13	300	3.14	29168	C 0 7 2 1 4 5 . _ M _ _ _ . 7 5 C - -	84.5	90S
18	49.90	339	2.82	29158	5 0 .		
17	53.62	346	2.91	29156	5 6 .		
15	61.62	398	2.61	29156	6 3 .		
13	69.00	461	2.27	29142	7 1 .		
12	75.56	505	2.10	29127	8 0 .		
10	88.26	560	1.98	29132	9 0 .		
9.2	99.79	632	1.80	29132	1 0 0		
8.8	104.32	688	1.60	29132	1 1 2		
7.9	115.92	761	1.44	29099	1 2 5		
6.7	138.00	861	1.39	29095	1 4 0		
6.1	151.12	936	1.30	29095	1 6 0		
4.4	208.65	1270	1.00	29000	2 1 2		
4.0	231.83	1405	0.90	28900	2 5 0		

NOTE:

Other output speeds are available using 2 & 8 pole motors. Please contact our Application Engineers

SERIES C SELECTION TABLE GEARED MOTORS

0.75 kW

6 POLE

N2 RPM	i	M2 Nm	Fm	N	Unit Designation	kg	
Output Speed	Ratio	Output Torque	Service Factor	Overhung Load	Column Entry 1 - 20 Spaces to be filled when entering order	Weight of Base Mount unit	Motor Size
9.5	97.33	643	2.08	29078	C 0 7 3 1 1 0 0 _ M _ _ _ . 7 5 C - -	93.5	90S
8.1	113.20	743	1.8	29048	1 1 8		
7.4	125.04	769	1.53	29096	1 3 2		
6.5	141.75	876	1.38	29065	1 5 0		
5.8	159.98	1038	1.29	28971	1 6 0		
5.4	170.81	1107	1.21	28971	1 8 0		
4.7	194.65	1187	1.07	28926	2 0 0		
4.1	226.39	1365	0.93	29000	2 2 5		
3.7	249.94	1601	0.84	28900	2 6 5		
9.3	98.53	631	3.71	41871	C 0 8 2 1 1 0 0 _ M _ _ _ . 7 5 C - -	134.5	90S
7.8	117.89	782	3.72	41879	1 2 5		
6.6	139.29	878	2.82	41858	1 4 0		
6.0	153.00	962	2.62	41858	1 6 0		
4.5	204.75	1270	2.07	41832	C 0 8 2 1 2 1 2 _ M _ _ _ . 7 5 C - -	134.5	90S
3.9	235.77	1443	1.81	41832	2 5 0		
3.7	249.73	1526	3.65	53800	C 0 9 2 1 2 5 0 _ M _ _ _ . 7 5 C - -	197.5	90S
1.6	558.41	3619	1.32	53383	C 0 9 4 1 5 6 0 _ M _ _ _ . 7 5 C - -	218.5	90S
1.4	649.47	4203	1.14	53383	6 3 0		
1.3	726.65	4692	1.02	53383	7 1 0		
1.2	774.48	5003	0.96	53383	8 0 0		
1.0	917.87	5914	0.81	53383	9 0 0		
1.9	495.31	3240	2.62	87299	C 1 0 4 1 5 0 0 _ M _ _ _ . 7 5 C - -	336.5	90S
1.7	544.84	3561	2.38	87299	5 6 0		
1.5	626.07	4087	2.07	87299	6 3 0		
1.3	709.95	4625	1.83	87299	7 1 0		
1.2	783.06	5101	1.66	87299	8 0 0		
1.0	896.77	5832	1.45	87299	9 0 0		
0.91	1013.93	6582	1.29	87299	1 0 C		
0.82	1126.71	7285	1.14	87375	1 1 C		
0.78	1175.54	7612	1.11	87299	1 2 C		
0.66	1402.11	9048	0.94	87299	1 4 C		
0.57	1606.71	10274	0.83	87299	1 6 C		

1.1 kW

4 POLE

164	8.59	53	1.52	2831	C 0 3 2 1 8 . 0 _ M _ _ _ 1 . 1 A - -	24.5	90S
121	11.61	71	1.23	2824	1 1 .		
107	13.20	80	1.12	2817	1 2 .		
94	14.95	91	1.03	2817	1 4 .		
86	16.36	88	0.98	2810	1 6 .		
74	19.12	115	0.86	2800	1 8 .		
68	20.61	123	0.82	2800	2 0 .		
64	22.11	117	0.80	2800	2 2 .		
164	8.59	54	2.51	5286	C 0 4 2 1 8 . 0 _ M _ _ _ 1 . 1 A - -	26.5	90S
121	11.61	72	2.04	5279	1 1 .		
107	13.20	82	1.87	5280	1 2 .		
94	14.95	92	1.71	5275	1 4 .		
86	16.36	91	1.57	5275	1 6 .		
74	19.12	117	1.43	5275	1 8 .		
68	20.61	125	1.36	5275	2 0 .		
64	22.11	121	1.28	5275	2 2 .		
56	25.14	136	1.18	5268	2 5 .		
50	28.48	153	1.09	5268	2 8 .		
42	33.71	201	0.95	5254	3 2 .		
39	36.43	193	0.91	5260	3 6 .		
36	39.26	206	0.87	5260	4 0 .		
170	8.31	53	3.88	7440	C 0 5 2 1 8 . 0 _ M _ _ _ 1 . 1 A - -	30.5	90S
121	11.66	74	3.20	7440	1 1 .		
110	12.85	81	3.02	7440	1 2 .		
97	14.59	92	2.80	7438	1 4 .		
88	16.09	93	3.41	7440	1 6 .		
76	18.53	116	2.42	7440	1 8 .		
67	21.05	131	2.25	7437	2 0 .		
62	22.56	128	2.68	7437	2 2 .		
57	24.86	140	2.50	7437	2 5 .		
50	28.24	158	2.29	7435	2 8 .		
43	32.55	199	1.71	7433	3 2 .		
39	35.86	197	1.91	7433	3 6 .		
35	40.74	222	1.74	7433	4 0 .		
30	46.84	284	1.34	7434	4 5 .		
28	50.93	307	1.27	7428	5 0 .		
25	55.45	297	1.40	7428	5 6 .		
22	63.00	333	1.28	7422	6 3 .		
19	73.37	434	0.88	7420	7 1 .		
16	90.67	470	1.02	7410	9 0 .		
14	98.57	504	0.95	7400	1 0 0		

NOTE:

Other output speeds are available using 2 & 8 pole motors. Please contact our Application Engineers

SERIES C SELECTION TABLE GEARED MOTORS

1.1 kW
4 POLE

N2 RPM	i	M2 Nm	Fm	N	Unit Designation	kg	
Output Speed	Ratio	Output Torque	Service Factor	Overhung Load	Column Entry 1 - 20 Spaces to be filled when entering order	Weight of Base Mount unit	Motor Size
67	20.96	137	3.86	11944	C 0 6 2 1 2 0 . _ M _ _ _ _ 1 . 1 A - -	42.5	90S
56	25.11	149	3.97	11944	2 5 .		
50	28.18	167	3.65	11936	2 8 .		
42	33.48	216	2.88	11820	3 2 .		
39	35.79	208	3.05	11836	3 6 .		
35	40.57	235	2.77	11832	4 0 .		
30	47.32	302	2.30	11795	4 5 .		
28	50.52	322	2.20	11764	5 0 .		
25	55.71	317	2.20	11811	5 6 .		
22	64.80	364	1.98	11764	6 3 .		
19	73.92	463	1.64	11644	7 1 .		
17	80.94	506	1.20	11644	8 0 .		
15	91.58	503	1.52	11644	C 0 6 2 1 9 0 . _ M _ _ _ _ 1 . 1 A - -	42.5	90S
14	97.78	534	1.43	11644	1 0 0		
13	110.57	680	0.93	11500	1 1 2		
14	103.86	637	1.20	11500	C 0 6 3 1 1 0 0 _ M _ _ _ _ 1 . 1 A - -	47.5	90S
12	117.99	722	1.06	11400	1 1 8		
11	130.00	687	1.11	11500	1 3 2		
10	147.69	773	0.99	11500	1 5 0		
46	30.81	205	3.86	29049	C 0 7 2 1 3 2 . _ M _ _ _ _ 1 . 1 A - -	84.5	90S
32	44.13	290	3.00	29166	4 5 .		
28	49.90	327	2.69	29166	5 0 .		
26	53.62	338	2.79	29168	5 6 .		
23	61.62	386	2.51	29152	6 3 .		
20	69.00	448	2.07	29152	7 1 .		
19	75.56	490	1.91	29136	8 0 .		
16	88.26	547	1.88	29133	9 0 .		
14	99.79	612	1.71	29133	1 0 0		
14	104.32	665	1.46	29133	1 1 2		
12	115.92	739	1.31	29100	1 2 5		
10	138.00	833	1.34	29084	1 4 0		
9.3	151.12	914	1.25	29084	1 6 0		
6.8	208.65	1234	0.97	29000	2 1 2		
6.1	231.83	1366	0.89	28900	2 5 0		
14	97.33	621	2.16	29097	C 0 7 3 1 1 0 0 _ M _ _ _ _ 1 . 1 A - -	93.5	90S
12	113.20	718	1.87	29029	1 1 8		
11	125.04	749	1.47	29087	1 3 2		
10	141.75	839	1.33	29100	1 5 0		
16	87.29	546	3.88	41877	C 0 8 2 1 9 0 . _ M _ _ _ _ 1 . 1 A - -	134.5	90S
14	98.53	612	3.53	41884	1 0 0		
12	117.89	756	3.77	41868	1 2 5		
10	139.29	851	2.71	41852	1 4 0		
9.2	153.00	932	2.52	41855	1 6 0		
6.9	204.75	1230	2.01	41810	2 1 2		
6.0	235.77	1409	1.79	41833	2 5 0		
9.0	156.45	952	2.85	41656	C 0 8 4 1 1 6 0 _ M _ _ _ _ 1 . 1 A - -	150.5	90S
8.0	176.60	1069	2.66	41656	1 8 0		
6.4	219.96	1338	2.03	41656	2 1 2		
5.7	248.29	1503	1.89	41656	2 5 0		
5.1	276.74	1683	1.61	41656	2 8 0		
4.5	312.37	1891	1.50	41656	3 1 5		
4.0	351.44	2137	1.27	41656	3 6 0		
3.5	398.40	2421	1.12	41656	4 0 0		
3.1	449.70	2720	1.05	41656	4 5 0		
3.0	475.14	2886	0.94	41656	5 0 0		
2.6	547.09	3321	0.82	41656	5 6 0		
5.6	249.73	1485	3.76	53800	C 0 9 2 1 2 5 0 _ M _ _ _ _ 1 . 1 A - -	197.5	90S
6.3	224.51	1396	3.42	53383	C 0 9 4 1 2 1 2 _ M _ _ _ _ 1 . 1 A - -	218.5	90S
5.7	249.43	1544	3.12	53383	2 5 0		
5.0	282.46	1756	2.72	53383	2 8 0		
4.5	313.81	1942	2.48	53383	3 1 5		
3.9	358.71	2229	2.14	53383	3 6 0		
3.5	406.64	2526	1.89	53383	4 0 0		
3.1	451.77	2794	1.72	53383	4 5 0		
2.9	484.97	3010	1.59	53383	5 0 0		
2.5	558.41	3464	1.38	53383	5 6 0		
2.2	649.47	4025	1.19	53383	6 3 0		
1.9	726.65	4495	1.06	53383	7 1 0		
1.8	774.48	4794	1.00	53383	8 0 0		
1.5	917.87	5672	0.84	53383	9 0 0		

NOTE:
Other output speeds are available using 2 & 8 pole motors. Please contact our Application Engineers

SERIES C SELECTION TABLE GEARED MOTORS

1.1 kW
4 POLE

1.1 kW
6 POLE

N2 RPM	i	M2 Nm	Fm	N	Unit Designation	kg			
Output Speed	Ratio	Output Torque	Service Factor	Overhung Load	Column Entry 1 - 20 Spaces to be filled when entering order	Weight of Base Mount unit	Motor Size		
2.8	495.31	3098	2.74	87299	C 1 0 4 1 5 0 0 _ M _ _ _ _ 1 . 1 A - -	336.5	90S		
2.6	544.84	3407	2.49	87299	5 6 0				
2.3	626.07	3912	2.17	87299	6 3 0				
2.0	709.95	4428	1.91	87299	7 1 0				
1.8	783.06	4885	1.73	87299	8 0 0				
1.6	896.77	5589	1.52	87299	9 0 0				
1.4	1013.93	6311	1.34	87299	1 0 C				
1.3	1126.71	6983	1.19	87375	1 1 C				
1.2	1175.54	7304	1.16	87299	1 2 C				
1.0	1402.11	8690	0.98	87299	1 4 C				
0.88	1606.71	9836	0.87	87299	1 6 C				
108	8.59	80	1.10	2817	C 0 3 2 1 8 . 0 _ M _ _ _ _ 1 . 1 C - -	25.5	90L		
80	11.61	106	0.90	2803	1 1 .				
70	13.20	121	0.82	2796	1 2 .				
108	8.59	81	1.83	5280	C 0 4 2 1 8 . 0 _ M _ _ _ _ 1 . 1 C - -	27.5	90L		
80	11.61	109	1.49	5271	1 1 .				
70	13.20	123	1.36	5266	1 2 .				
62	14.95	139	1.24	5266	1 4 .				
57	16.36	135	1.17	5266	1 6 .				
48	19.12	177	1.03	5261	1 8 .				
45	20.61	188	0.99	5254	2 0 .				
42	22.11	179	0.95	5254	2 2 .				
37	25.14	202	0.86	5254	2 5 .				
111	8.31	80	3.03	7440	C 0 5 2 1 8 . 0 _ M _ _ _ _ 1 . 1 C - -			31.5	90L
79	11.66	112	2.47	7440	1 1 .				
72	12.85	123	2.33	7440	1 2 .				
63	14.59	139	2.15	7440	1 4 .				
58	16.09	138	2.51	7440	1 6 .				
50	18.53	175	1.86	7436	1 8 .				
44	21.05	196	1.72	7432	2 0 .				
41	22.56	190	1.95	7436	2 2 .				
37	24.86	208	1.82	7432	2 5 .				
33	28.24	234	1.66	7428	2 8 .				
28	32.55	300	1.29	7420	3 2 .				
26	35.86	293	1.39	7420	3 6 .				
23	40.74	330	1.27	7416	4 0 .				
20	46.84	425	0.95	7407	4 5 .				
18	50.93	462	0.88	7401	5 0 .				
17	55.45	441	1.02	7407	5 6 .				
15	63.00	496	0.93	7401	6 3 .				
71	12.97	130	3.99	11928	C 0 6 2 1 1 2 . _ M _ _ _ _ 1 . 1 C - -	43.5	90L		
64	14.56	145	3.71	11914	1 4 .				
50	18.49	183	3.20	11900	1 8 .				
44	20.96	207	2.95	11886	2 0 .				
41	22.40	200	3.11	11900	2 2 .				
37	25.11	223	2.85	11886	2 5 .				
33	28.18	248	2.62	11879	2 8 .				
28	33.48	326	2.17	11739	3 2 .				
26	35.79	310	2.21	11759	3 6 .				
23	40.57	349	2.01	11733	4 0 .				
20	47.32	455	1.68	11693	4 5 .				
18	50.52	483	1.59	11670	5 0 .				
17	55.71	470	1.60	11670	5 6 .				
14	64.80	539	1.42	11623	6 3 .				
13	73.92	699	1.09	11473	7 1 .				
11	80.94	757	0.91	11402	8 0 .				
10	91.58	747	1.02	11502	9 0 .				
9.5	97.78	794	0.96	11402	1 0 0				
30	30.81	309	2.78	29157	C 0 7 2 1 3 2 . _ M _ _ _ _ 1 . 1 C - -	85.5	90L		
21	44.13	439	2.15	29139	4 5 .				
19	49.90	494	1.94	29119	5 0 .				
17	53.62	505	2.00	29116	5 6 .				
15	61.62	582	1.79	29116	6 3 .				
13	69.00	673	1.56	29088	7 1 .				
12	75.56	737	1.44	29061	8 0 .				
10	88.26	817	1.36	29070	9 0 .				
9.3	99.79	923	1.24	29070	1 0 0				
8.9	104.32	1004	1.09	29070	1 1 2				
8.0	115.92	1111	0.99	29006	1 2 5				
6.7	138.00	1256	0.95	29000	1 4 0				
6.1	151.12	1365	0.89	29000	1 6 0				
10	97.33	938	1.43	29011	C 0 7 3 1 1 0 0 _ M _ _ _ _ 1 . 1 C - -	94.5	90L		
8.2	113.20	1084	1.24	28964	1 1 8				
7.4	125.04	1122	1.05	29000	1 3 2				
6.5	141.75	1279	0.95	28941	1 5 0				

NOTE:
Other output speeds are available using 2 & 8 pole motors. Please contact our Application Engineers

SERIES C SELECTION TABLE GEARED MOTORS

1.1 kW
6 POLE

N2 RPM	i	M2 Nm	Fm	N	Unit Designation	kg	
Output Speed	Ratio	Output Torque	Service Factor	Overhung Load	Column Entry 1 - 20 Spaces to be filled when entering order	Weight of Base Mount unit	Motor Size
12	76.50	754	3.77	41843	C 0 8 2 1 8 0 . _ M _ - _ - 1 . 1 C - -	135.5	90L
11	87.29	819	2.79	41859	9 0 .		
9.4	98.53	921	2.54	41844	1 0 0		
9.0	102.38	1000	3.04	41844	1 1 2		
7.8	117.89	1141	2.55	41860	1 2 5		
6.6	139.29	1281	1.94	41820	1 4 0		
6.0	153.00	1403	1.80	41820	1 6 0		
5.9	156.45	1458	1.86	41656	C 0 8 4 1 1 6 0 _ M _ - _ - 1 . 1 C - -	151.5	90L
5.2	176.60	1637	1.74	41656	1 8 0		
4.2	219.96	2048	1.33	41656	2 1 2		
3.7	248.29	2301	1.24	41656	2 5 0		
3.3	276.74	2574	1.05	41656	2 8 0		
3.0	312.37	2892	0.98	41656	3 1 5		
2.6	351.44	3265	0.83	41656	3 6 0		
7.7	119.38	1171	3.97	53755	C 0 9 2 1 1 2 5 _ M _ - _ - 1 . 1 C - -	198.5	90L
5.7	161.44	1474	3.78	53741	C 0 9 2 1 1 6 0 _ M _ - _ - 1 . 1 C - -	198.5	90L
4.2	222.08	1990	2.80	53713	2 1 2		
3.7	249.73	2227	2.51	53703	2 5 0		
5.8	159.68	1518	3.15	53383	C 0 9 4 1 1 6 0 _ M _ - _ - 1 . 1 C - -	219.5	90L
5.2	177.41	1679	2.87	53383	1 8 0		
4.1	224.51	2132	2.24	53383	2 1 2		
3.7	249.43	2360	2.04	53383	2 5 0		
3.3	282.46	2681	1.78	53383	2 8 0		
2.9	313.81	2967	1.62	53383	3 1 5		
2.6	358.71	3401	1.41	53383	3 6 0		
2.3	406.64	3853	1.24	53383	4 0 0		
2.0	451.77	4264	1.13	53383	4 5 0		
1.9	484.97	4590	1.04	53383	5 0 0		
1.7	558.41	5279	0.91	53383	5 6 0		
1.9	495.31	4726	1.79	87299	C 1 0 4 1 5 0 0 _ M _ - _ - 1 . 1 C - -	337.5	90L
1.7	544.84	5195	1.63	87299	5 6 0		
1.5	626.07	5963	1.42	87299	6 3 0		
1.3	709.95	6747	1.26	87299	7 1 0		
1.2	783.06	7441	1.14	87299	8 0 0		
1.0	896.77	8508	1.00	87299	9 0 0		
0.91	1013.93	9602	0.88	87299	1 0 C		

1.5 kW
4 POLE

165	8.59	72	1.12	2820	C 0 3 2 1 8 . 0 _ M _ - _ - 1 . 5 A - -	25.5	90L
122	11.61	96	0.91	2810	1 1 .		
108	13.20	109	0.83	2800	1 2 .		
165	8.59	73	1.85	5285	C 0 4 2 1 8 . 0 _ M _ - _ - 1 . 5 A - -	27.5	90L
122	11.61	98	1.51	5275	1 1 .		
108	13.20	111	1.38	5276	1 2 .		
95	14.95	125	1.27	5270	1 4 .		
87	16.36	123	1.16	5270	1 6 .		
74	19.12	158	1.06	5270	1 8 .		
69	20.61	170	1.01	5270	2 0 .		
64	22.11	164	0.95	5270	2 2 .		
56	25.14	185	0.87	5260	2 5 .		
50	28.48	207	0.80	5260	2 8 .		
171	8.31	72	2.87	7440	C 0 5 2 1 8 . 0 _ M _ - _ - 1 . 5 A - -	31.5	90L
122	11.66	100	2.36	7440	1 1 .		
111	12.85	110	2.23	7440	1 2 .		
97	14.59	125	2.07	7437	1 4 .		
88	16.09	126	2.52	7440	1 6 .		
77	18.53	157	1.79	7440	1 8 .		
67	21.05	177	1.66	7436	2 0 .		
63	22.56	174	1.98	7436	2 2 .		
57	24.86	190	1.85	7436	2 5 .		
50	28.24	214	1.69	7432	2 8 .		
44	32.55	270	1.26	7428	3 2 .		
40	35.86	268	1.41	7428	3 6 .		
35	40.74	301	1.29	7428	4 0 .		
30	46.84	384	0.99	7430	4 5 .		
28	50.93	415	0.94	7420	5 0 .		
26	55.45	402	1.03	7420	5 6 .		
23	63.00	451	0.95	7410	6 3 .		

NOTE:
Other output speeds are available using 2 & 8 pole motors. Please contact our Application Engineers

SERIES C SELECTION TABLE GEARED MOTORS

1.5 kW

4 POLE

N2 RPM	i	M2 Nm	Fm	N	Unit Designation	kg	
Output Speed	Ratio	Output Torque	Service Factor	Overhung Load	Column Entry 1 - 20 Spaces to be filled when entering order	Weight of Base Mount unit	Motor Size
109	12.97	116	3.82	11945	C 0 6 2 1 1 2 . _ M _ - _ _ 1 . 5 A - -	43.5	90L
98	14.56	130	3.56	11923	1 4 .		
89	15.93	131	3.94	11942	1 6 .		
77	18.49	164	3.08	11904	1 8 .		
68	20.96	186	2.85	11904	2 0 .		
63	22.40	182	3.18	11904	2 2 .		
57	25.11	202	2.93	11904	2 5 .		
50	28.18	226	2.70	11889	2 8 .		
42	33.48	292	2.13	11762	3 2 .		
40	35.79	282	2.25	11789	3 6 .		
35	40.57	318	2.04	11783	4 0 .		
30	47.32	409	1.70	11712	4 5 .		
28	50.52	436	1.63	11668	5 0 .		
25	55.71	429	1.63	11734	5 6 .		
22	64.80	493	1.46	11668	6 3 .		
19	73.92	627	1.21	11500	7 1 .		
18	80.94	685	0.89	11500	8 0 .		
16	91.58	682	1.12	11500	9 0 .		
15	97.78	724	1.06	11500	1 0 0		
46	30.81	278	2.85	28940	C 0 7 2 1 3 2 . _ M _ - _ _ 1 . 5 A - -	85.5	90L
32	44.13	393	2.21	29142	4 5 .		
28	49.90	443	1.98	29142	5 0 .		
26	53.62	458	2.06	29144	5 6 .		
23	61.62	523	1.85	29117	C 0 7 2 1 6 3 . _ M _ - _ _ 1 . 5 A - -	85.5	90L
21	69.00	606	1.53	29117	7 1 .		
19	75.56	663	1.41	29089	8 0 .		
16	88.26	740	1.39	29084	9 0 .		
14	99.79	829	1.27	29084	1 0 0		
14	104.32	901	1.08	29084	1 1 2		
12	115.92	1000	0.97	29027	1 2 5		
10	138.00	1128	0.99	29000	1 4 0		
9.4	151.12	1238	0.92	29000	1 6 0		
15	97.33	841	1.59	29056	C 0 7 3 1 1 0 0 _ M _ - _ _ 1 . 5 A - -	94.5	90L
13	113.20	972	1.38	28960	1 1 8		
11	125.04	1014	1.08	29006	1 3 2		
10	141.75	1136	0.99	29027	1 5 0		
8.9	159.98	1359	0.99	28868	1 6 0		
8.3	170.81	1445	0.93	28900	1 8 0		
19	76.50	677	3.78	41845	C 0 8 2 1 8 0 . _ M _ - _ _ 1 . 5 A - -	135.5	90L
16	87.29	739	2.87	41861	9 0 .		
14	98.53	829	2.60	41872	1 0 0		
14	102.38	897	3.08	41872	1 1 2		
12	117.89	1024	2.78	41844	1 2 5		
10	139.29	1152	2.00	41817	1 4 0		
9.3	153.00	1262	1.86	41822	1 6 0		
6.9	204.75	1666	1.48	41744	2 1 2		
6.0	235.77	1908	1.33	41784	2 5 0		
9.1	156.45	1290	2.11	41656	C 0 8 4 1 1 6 0 _ M _ - _ _ 1 . 5 A - -	151.5	90L
8.0	176.60	1448	1.96	41656	1 8 0		
6.5	219.96	1812	1.50	41656	2 1 2		
5.7	248.29	2035	1.40	41656	2 5 0		
5.1	276.74	2279	1.19	41656	2 8 0		
4.5	312.37	2560	1.11	41656	3 1 5		
4.0	351.44	2893	0.94	41656	3 6 0		
3.6	398.40	3279	0.83	41656	4 0 0		
6.4	222.08	1803	3.09	53736	C 0 9 2 1 2 1 2 _ M _ - _ _ 1 . 5 A - -	198.5	90L
5.7	249.73	2011	2.77	53727	2 5 0		
8.9	159.68	1345	3.55	53383	C 0 9 4 1 1 6 0 _ M _ - _ _ 1 . 5 A - -	219.5	90L
8.0	177.41	1488	3.24	53383	1 8 0		
6.3	224.51	1891	2.53	53383	2 1 2		
5.7	249.43	2091	2.30	53383	2 5 0		
5.0	282.46	2378	2.01	53383	2 8 0		
4.5	313.81	2630	1.83	53383	3 1 5		
4.0	358.71	3018	1.58	53383	3 6 0		
3.5	406.64	3420	1.40	53383	4 0 0		
3.1	451.77	3783	1.27	53383	4 5 0		
2.9	484.97	4076	1.17	53383	5 0 0		
2.5	558.41	4690	1.02	53383	5 6 0		
2.2	649.47	5450	0.88	53383	6 3 0		
2.9	495.31	4195	2.02	87299	C 1 0 4 1 5 0 0 _ M _ - _ _ 1 . 5 A - -	337.5	90L
2.6	544.84	4613	1.84	87299	5 6 0		
2.3	626.07	5297	1.60	87299	6 3 0		
2.0	709.95	5996	1.41	87299	7 1 0		
1.8	783.06	6615	1.28	87299	8 0 0		
1.6	896.77	7568	1.12	87299	9 0 0		
1.4	1013.93	8545	0.99	87299	1 0 C		
1.3	1126.71	9455	0.88	87375	1 1 C		
1.2	1175.54	9890	0.86	87299	1 2 C		

NOTE:

Other output speeds are available using 2 & 8 pole motors. Please contact our Application Engineers

SERIES C

SELECTION TABLE

GEARED MOTORS

1.5 kW
6 POLE

N2 RPM	i	M2 Nm	Fm	N	Unit Designation	kg	
Output Speed	Ratio	Output Torque	Service Factor	Overhung Load	Column Entry 1 - 20 Spaces to be filled when entering order	Weight of Base Mount unit	Motor Size
108	8.59	109	0.81	2800	C 0 3 2 1 8 . 0 _ M _ _ _ 1 . 5 C - -	35	100L
108	8.59	111	1.34	5276	C 0 4 2 1 8 . 0 _ M _ _ _ 1 . 5 C - -	37	100L
80	11.61	149	1.09	5263	1 1 .		
70	13.20	167	1.00	5256	1 2 .		
62	14.95	189	0.91	5256	1 4 .		
57	16.36	184	0.85	5256	1 6 .		
111	8.31	110	2.22	7440	C 0 5 2 1 8 . 0 _ M _ _ _ 1 . 5 C - -	41	100L
79	11.66	152	1.81	7440	1 1 .		
72	12.85	167	1.71	7440	1 2 .		
63	14.59	189	1.58	7440	1 4 .		
58	16.09	189	1.84	7440	1 6 .		
50	18.53	238	1.36	7433	1 8 .		
44	21.05	268	1.26	7427	2 0 .		
41	22.56	259	1.43	7433	2 2 .		
37	24.86	284	1.34	7427	2 5 .		
33	28.24	320	1.21	7421	2 8 .		
28	32.55	409	0.94	7409	3 2 .		
26	35.86	400	1.02	7409	3 6 .		
23	40.74	450	0.93	7402	4 0 .		
112	8.23	114	3.85	11933	C 0 6 2 1 8 . 0 _ M _ _ _ 1 . 5 C - -	53	100L
80	11.57	158	3.13	11911	1 1 .		
71	12.97	177	2.92	11889	1 2 .		
64	14.56	198	2.72	11867	1 4 .		
58	15.93	198	2.94	11889	1 6 .		
50	18.49	250	2.34	11845	1 8 .		
44	20.96	282	2.16	11823	2 0 .		
41	22.40	273	2.28	11845	2 2 .		
37	25.11	304	2.09	11823	2 5 .		
33	28.18	339	1.92	11813	2 8 .		
28	33.48	445	1.59	11650	3 2 .		
26	35.79	423	1.62	11682	3 6 .		
23	40.57	477	1.48	11642	4 0 .		
20	47.32	621	1.23	11568	4 5 .		
18	50.52	658	1.16	11535	5 0 .		
17	55.71	642	1.18	11535	5 6 .		
14	64.80	736	1.04	11469	6 3 .		
13	73.92	953	0.80	11300	7 1 .		
59	15.80	214	3.73	29200	C 0 7 2 1 1 6 . _ M _ _ _ 1 . 5 C - -	95	100L
46	20.07	278	3.80	29200	2 0 .		
42	21.89	293	2.93	29200	2 2 .		
38	24.59	328	2.69	29200	2 5 .		
34	27.03	359	2.50	29200	2 8 .		
30	30.81	422	2.04	29133	3 2 .		
26	35.31	464	2.04	29200	3 6 .		
23	40.15	524	1.84	29200	4 0 .		
21	44.13	598	1.58	29106	4 5 .		
19	49.90	674	1.42	29075	5 0 .		
17	53.62	689	1.46	29071	5 6 .		
15	61.62	793	1.31	29071	6 3 .		
13	69.00	918	1.14	29028	7 1 .		
12	75.56	1006	1.05	28985	8 0 .		
10	88.26	1114	1.00	29000	9 0 .		
9.3	99.79	1258	0.91	29000	1 0 0 .		
8.9	104.32	1369	0.80	29000	1 1 2 .		
10	97.33	1279	1.05	28934	C 0 7 3 1 1 0 0 _ M _ _ _ 1 . 5 C - -	104	100L
8.2	113.20	1479	0.91	28868	1 1 8 .		
23	39.51	524	3.80	41900	C 0 8 2 1 4 0 . _ M _ _ _ 1 . 5 C - -	145	100L
19	49.26	672	3.78	41836	5 0 .		
17	54.60	713	2.94	41900	5 6 .		
15	63.56	824	2.61	41900	6 3 .		
13	69.64	938	2.96	41811	7 1 .		
12	76.50	1028	2.76	41811	8 0 .		
11	87.29	1117	2.05	41837	9 0 .		
9.4	98.53	1256	1.86	41814	1 0 0 .		
9.0	102.38	1363	2.23	41814	1 1 2 .		
7.8	117.89	1556	1.87	41838	1 2 5 .		
6.6	139.29	1746	1.42	41776	1 4 0 .		
6.0	153.00	1913	1.32	41776	1 6 0 .		
4.5	204.75	2527	1.04	41700	2 1 2 .		
3.9	235.77	2872	0.91	41700	2 5 0 .		
5.9	156.45	1988	1.37	41656	C 0 8 4 1 1 6 0 _ M _ _ _ 1 . 5 C - -	161	100L
5.2	176.60	2233	1.27	41656	1 8 0 .		
4.2	219.96	2792	0.97	41656	2 1 2 .		
3.7	248.29	3137	0.91	41656	2 5 0 .		
8.7	106.17	1432	3.22	53721	C 0 9 2 1 1 1 2 _ M _ _ _ 1 . 5 C - -	208	100L
7.7	119.38	1597	2.91	53705	1 2 5 .		
6.3	146.23	1828	3.05	53689	1 4 0 .		
5.7	161.44	2010	2.78	53673	1 6 0 .		
4.2	222.08	2714	2.06	53615	2 1 2 .		
3.7	249.73	3037	1.84	53592	2 5 0 .		

NOTE:
Other output speeds are available using 2 & 8 pole motors. Please contact our Application Engineers

SERIES C SELECTION TABLE GEARED MOTORS

1.5 kW
6 POLE

2.2 kW
4 POLE

N2 RPM	i	M2 Nm	Fm	N	Unit Designation	kg	
Output Speed	Ratio	Output Torque	Service Factor	Overhung Load	Column Entry 1 - 20 Spaces to be filled when entering order	Weight of Base Mount unit	Motor Size
5.8	159.68	2070	2.31	53383	C 0 9 4 1 1 6 0 _ M _ _ _ _ 1 . 5 C - -	229	100L
5.2	177.41	2290	2.10	53383	1 8 0		
4.1	224.51	2908	1.64	53383	2 1 2		
3.7	249.43	3218	1.50	53383	2 5 0		
3.3	282.46	3656	1.31	53383	2 8 0		
2.9	313.81	4046	1.19	53383	3 1 5		
2.6	358.71	4638	1.03	53383	3 6 0		
2.3	406.64	5255	0.91	53383	4 0 0		
2.0	451.77	5815	0.83	53383	4 5 0		
5.5	166.73	2139	3.98	87400	C 1 0 2 1 1 6 0 _ M _ _ _ _ 1 . 5 C - -	305	100L
4.1	225.50	2845	3.10	87400	2 1 2		
3.8	242.27	3044	2.90	87400	2 5 0		
1.9	495.31	6445	1.31	87299	C 1 0 4 1 5 0 0 0 _ M _ _ _ _ 1 . 5 C - -	347	100L
1.7	544.84	7085	1.20	87299	5 6 0		
1.5	626.07	8131	1.04	87299	6 3 0		
1.3	709.95	9200	0.92	87299	7 1 0		
1.2	783.06	10147	0.84	87299	8 0 0		
166	8.59	107	1.27	5282	C 0 4 2 1 8 . 0 _ M _ _ _ _ 2 . 2 A - -	37	100L
123	11.61	144	1.03	5268	1 1 .		
108	13.20	163	0.94	5270	1 2 .		
95	14.95	183	0.87	5260	1 4 .		
171	8.31	106	1.96	7440	C 0 5 2 1 8 . 0 _ M _ _ _ _ 2 . 2 A - -	41	100L
122	11.66	147	1.62	7440	1 1 .		
111	12.85	161	1.53	7440	1 2 .		
98	14.59	182	1.42	7435	1 4 .		
89	16.09	185	1.72	7440	1 6 .		
77	18.53	230	1.22	7440	1 8 .		
68	21.05	259	1.13	7433	2 0 .		
63	22.56	254	1.35	7433	2 2 .		
57	24.86	278	1.26	7433	2 5 .		
50	28.24	312	1.16	7426	2 8 .		
44	32.55	395	0.86	7420	3 2 .		
40	35.86	391	0.96	7420	3 6 .		
35	40.74	440	0.88	7420	4 0 .		
173	8.23	109	3.40	11928	C 0 6 2 1 8 . 0 _ M _ _ _ _ 2 . 2 A - -	53	100L
123	11.57	152	2.80	11905	1 1 .		
110	12.97	170	2.61	11905	1 2 .		
98	14.56	191	2.44	11866	1 4 .		
89	15.93	191	2.69	11900	1 6 .		
77	18.49	240	2.11	11833	1 8 .		
68	20.96	272	1.95	11833	2 0 .		
64	22.40	266	2.18	11833	2 2 .		
57	25.11	296	2.01	11833	2 5 .		
51	28.18	331	1.84	11808	2 8 .		
43	33.48	427	1.46	11660	3 2 .		
40	35.79	413	1.54	11708	3 6 .		
35	40.57	465	1.40	11697	4 0 .		
30	47.32	598	1.16	11566	4 5 .		
28	50.52	637	1.11	11500	5 0 .		
26	55.71	627	1.11	11600	5 6 .		
22	64.80	720	1.00	11500	6 3 .		
90	15.80	205	3.49	27500	C 0 7 2 1 1 6 . _ M _ _ _ _ 2 . 2 A - -	95	100L
81	17.66	237	3.70	28200	1 8 .		
71	20.07	269	3.42	29200	2 0 .		
65	21.89	282	2.77	29200	2 2 .		
58	24.59	315	2.54	29200	2 5 .		
53	27.03	347	2.37	29200	2 8 .		
46	30.81	406	1.95	28748	3 2 .		
40	35.31	448	1.94	29200	3 6 .		
35	40.15	507	1.76	29200	4 0 .		
32	44.13	575	1.51	29100	4 5 .		
29	49.90	648	1.36	29100	5 0 .		
27	53.62	670	1.41	29104	5 6 .		
23	61.62	764	1.27	29056	6 3 .		
21	69.00	886	1.05	29056	7 1 .		
19	75.56	970	0.96	29008	8 0 .		
16	88.26	1082	0.95	29000	9 0 .		
14	99.79	1211	0.87	29000	1 0 0		
15	97.33	1229	1.09	28983	C 0 7 3 1 1 0 0 _ M _ _ _ _ 2 . 2 A - -	104	100L
13	113.20	1421	0.94	28838	1 1 8		

NOTE:
Other output speeds are available using 2 & 8 pole motors. Please contact our Application Engineers

SERIES C SELECTION TABLE GEARED MOTORS

2.2 kW
4 POLE

N2 RPM	i	M2 Nm	Fm	N	Unit Designation	kg	
Output Speed	Ratio	Output Torque	Service Factor	Overhung Load	Column Entry 1 - 20 Spaces to be filled when entering order	Weight of Base Mount unit	Motor Size
40	35.20	453	3.97	41900	C 0 8 2 1 3 6 . _ M _ _ _ _ 2 . 2 A - -	145	100L
36	39.51	506	3.64	41900	4 0 .		
33	43.64	576	3.77	41063	4 5 .		
29	49.26	646	3.48	41638	5 0 .		
26	54.60	690	2.84	41900	5 6 .		
22	63.56	797	2.52	41900	6 3 .		
20	69.64	901	2.76	41828	7 1 .		
19	76.50	989	2.59	41805	8 0 .		
16	87.29	1081	1.96	41833	9 0 .		
14	98.53	1211	1.78	41852	1 0 0		
14	102.38	1311	2.10	41852	1 1 2		
12	117.89	1497	1.90	41804	1 2 5		
10	139.29	1684	1.37	41756	1 4 0		
9.3	153.00	1845	1.27	41765	1 6 0		
7.0	204.75	2435	1.01	41630	2 1 2		
6.0	235.77	2789	0.91	41700	2 5 0		
9.1	156.45	1885	1.44	41656	C 0 8 4 1 1 6 0 _ M _ _ _ _ 2 . 2 A - -	161	100L
8.1	176.60	2117	1.34	41656	1 8 0		
6.5	219.96	2649	1.03	41656	2 1 2		
5.7	248.29	2975	0.96	41656	2 5 0		
5.1	276.74	3332	0.82	41656	2 8 0		
14	103.53	1280	3.79	53722	C 0 9 2 1 1 0 0 _ M _ _ _ _ 2 . 2 A - -	208	100L
13	106.17	1376	3.23	53731	1 1 2		
12	119.38	1539	2.92	53714	1 2 5		
10	146.23	1772	2.98	53696	1 4 0		
8.8	161.44	1950	2.78	53679	1 6 0		
6.4	222.08	2635	2.12	53625	2 1 2		
5.7	249.73	2939	1.90	53600	2 5 0		
8.9	159.68	1966	2.43	53383	C 0 9 4 1 1 6 0 _ M _ _ _ _ 2 . 2 A - -	229	100L
8.0	177.41	2175	2.21	53383	1 8 0		
6.3	224.51	2763	1.73	53383	2 1 2		
5.7	249.43	3057	1.58	53383	2 5 0		
5.0	282.46	3475	1.38	53383	2 8 0		
4.5	313.81	3844	1.25	53383	3 1 5		
4.0	358.71	4411	1.08	53383	3 6 0		
3.5	406.64	4998	0.96	53383	4 0 0		
3.2	451.77	5530	0.87	53383	4 5 0		
2.9	484.97	5957	0.80	53383	5 0 0		
8.5	166.73	2067	3.85	87400	C 1 0 2 1 1 6 0 _ M _ _ _ _ 2 . 2 A - -	305	100L
6.3	225.50	2755	3.04	87400	2 1 2		
5.9	242.27	2948	2.87	87400	2 5 0		
2.9	495.31	6132	1.38	87299	C 1 0 4 1 5 0 0 _ M _ _ _ _ 2 . 2 A - -	347	100L
2.6	544.84	6742	1.26	87299	5 6 0		
2.3	626.07	7741	1.09	87299	6 3 0		
2.0	709.95	8763	0.97	87299	7 1 0		
1.8	783.06	9669	0.88	87299	8 0 0		

2.2 kW
6 POLE

111	8.59	159	0.94	5270	C 0 4 2 1 8 . 0 _ M _ _ _ _ 2 . 2 C - -	45	112M
114	8.31	157	1.56	7440	C 0 5 2 1 8 . 0 _ M _ _ _ _ 2 . 2 C - -	49	112M
81	11.66	218	1.27	7440	1 1 .		
74	12.85	239	1.20	7440	1 2 .		
65	14.59	271	1.11	7440	1 4 .		
59	16.09	270	1.29	7440	1 6 .		
51	18.53	340	0.95	7430	1 8 .		
45	21.05	383	0.88	7420	2 0 .		
42	22.56	370	1.00	7430	2 2 .		
38	24.86	406	0.94	7420	2 5 .		
34	28.24	457	0.85	7410	2 8 .		
115	8.23	162	2.69	11892	C 0 6 2 1 8 . 0 _ M _ _ _ _ 2 . 2 C - -	65	112M
82	11.57	226	2.20	11857	1 1 .		
73	12.97	253	2.05	11821	1 2 .		
65	14.56	283	1.90	11785	1 4 .		
60	15.93	283	2.06	11821	1 6 .		
51	18.49	357	1.64	11750	1 8 .		
45	20.96	403	1.52	11714	2 0 .		
42	22.40	390	1.60	11750	2 2 .		
38	25.11	435	1.46	11714	2 5 .		
34	28.18	484	1.34	11697	2 8 .		
28	33.48	635	1.12	11496	3 2 .		
27	35.79	605	1.13	11547	3 6 .		
23	40.57	681	1.03	11482	4 0 .		
20	47.32	886	0.86	11350	4 5 .		
19	50.52	940	0.81	11300	5 0 .		
17	55.71	917	0.82	11300	5 6 .		

NOTE:
Other output speeds are available using 2 & 8 pole motors. Please contact our Application Engineers

SERIES C SELECTION TABLE GEARED MOTORS

2.2 kW

6 POLE

N2 RPM	i	M2 Nm	Fm	N	Unit Designation	kg	
Output Speed	Ratio	Output Torque	Service Factor	Overhung Load	Column Entry 1 - 20 Spaces to be filled when entering order	Weight of Base Mount unit	Motor Size
120	7.90	160	3.84	24856	C 0 7 2 1 8 . 0 _ M _ - _ _ 2 . 2 C - -	109	112M
87	10.94	221	3.84	26975	1 1 .		
77	12.29	248	3.61	27838	1 2 .		
70	13.52	272	3.41	28591	1 4 .		
60	15.80	305	2.61	28978	1 6 .		
54	17.66	353	2.89	28908	1 8 .		
47	20.07	398	2.66	28966	2 0 .		
43	21.89	419	2.05	29165	2 2 .		
39	24.59	468	1.88	29165	2 5 .		
35	27.03	513	1.75	29165	C 0 7 2 1 2 8 . _ M _ - _ _ 2 . 2 C - -	109	112M
31	30.81	603	1.43	29092	3 2 .		
27	35.31	663	1.43	29144	3 6 .		
24	40.15	749	1.29	29116	4 0 .		
22	44.13	854	1.11	29048	4 5 .		
19	49.90	963	0.99	28998	5 0 .		
18	53.62	984	1.03	28991	5 6 .		
15	61.62	1133	0.92	28991	6 3 .		
14	69.00	1311	0.80	28921	7 1 .		
39	24.47	474	3.84	41597	C 0 8 2 1 2 5 . _ M _ - _ _ 2 . 2 C - -	152	112M
35	27.22	524	3.54	41795	2 8 .		
30	31.78	626	3.56	41748	3 2 .		
27	35.20	670	2.91	41888	3 6 .		
24	39.51	748	2.66	41876	4 0 .		
22	43.64	855	2.87	41848	4 5 .		
19	49.26	960	2.64	41797	5 0 .		
17	54.60	1019	2.06	41865	5 6 .		
15	63.56	1177	1.83	41847	6 3 .		
14	69.64	1340	2.07	41757	7 1 .		
12	76.50	1468	1.93	41757	8 0 .		
11	87.29	1595	1.43	41799	9 0 .		
10	98.53	1793	1.30	41760	1 0 0		
9.3	102.38	1947	1.56	41760	1 1 2		
8.1	117.89	2223	1.31	41800	1 2 5		
6.8	139.29	2494	0.99	41700	1 4 0		
6.2	153.00	2732	0.92	41700	1 6 0		
6.1	156.45	2839	0.96	41656	C 0 8 4 1 1 6 0 _ M _ - _ _ 2 . 2 C - -	175	112M
5.4	176.60	3189	0.89	41656	1 8 0		
14	69.91	1363	3.26	53714	C 0 9 2 1 7 1 . _ M _ - _ _ 2 . 2 C - -	215	112M
12	77.18	1502	2.98	53692	8 0 .		
10	93.18	1703	3.08	53671	9 0 .		
9.2	103.53	1883	2.86	53649	1 0 0		
8.9	106.17	2045	2.25	53647	1 1 2		
8.0	119.38	2282	2.04	53616	1 2 5		
6.5	146.23	2611	2.14	53586	1 4 0		
5.9	161.44	2871	1.94	53555	1 6 0		
4.3	222.08	3876	1.44	53443	2 1 2		
3.8	249.73	4337	1.29	53398	2 5 0		
5.9	159.68	2956	1.62	53383	C 0 9 4 1 1 6 0 _ M _ - _ _ 2 . 2 C - -	243	112M
5.4	177.41	3270	1.47	53383	1 8 0		
4.2	224.51	4153	1.15	53383	2 1 2		
3.8	249.43	4596	1.05	53383	2 5 0		
3.4	282.46	5221	0.92	53383	2 8 0		
3.0	313.81	5778	0.83	53383	3 1 5		
8.2	115.82	2240	3.53	87400	C 1 0 2 1 1 2 5 _ M _ - _ _ 2 . 2 C - -	312	112M
6.6	144.71	2668	3.12	87376	1 4 0		
5.7	166.73	3055	2.79	87365	1 6 0		
4.2	225.50	4064	2.17	87347	2 1 2		
3.9	242.27	4347	2.03	87347	2 5 0		
1.9	495.31	9204	0.92	87299	C 1 0 4 1 5 0 0 _ M _ - _ _ 2 . 2 C - -	361	112M
1.7	544.84	10117	0.84	87299	5 6 0		

NOTE:

Other output speeds are available using 2 & 8 pole motors. Please contact our Application Engineers

SERIES C SELECTION TABLE GEARED MOTORS

3.0 kW
4 POLE

N2 RPM	i	M2 Nm	Fm	N	Unit Designation	kg	
Output Speed	Ratio	Output Torque	Service Factor	Overhung Load	Column Entry 1 - 20 Spaces to be filled when entering order	Weight of Base Mount unit	Motor Size
166	8.59	147	0.93	5280	C 0 4 2 1 8 . 0 _ M _ _ _ 3 . 0 A - -	37	100L
171	8.31	145	1.44	7440	C 0 5 2 1 8 . 0 _ M _ _ _ 3 . 0 A - -	41	100L
122	11.66	200	1.19	7440	1 1 .		
111	12.85	220	1.12	7440	1 2 .		
98	14.59	249	1.04	7432	1 4 .		
89	16.09	253	1.26	7440	1 6 .		
77	18.53	314	0.90	7440	1 8 .		
68	21.05	354	0.83	7430	2 0 .		
63	22.56	347	0.99	7430	2 2 .		
57	24.86	379	0.93	7430	2 5 .		
50	28.24	426	0.85	7420	2 8 .		
173	8.23	149	2.50	11894	C 0 6 2 1 8 . 0 _ M _ _ _ 3 . 0 A - -	53	100L
123	11.57	208	2.05	11858	1 1 .		
110	12.97	232	1.92	11858	1 2 .		
98	14.56	260	1.79	11802	1 4 .		
89	15.93	261	1.98	11851	1 6 .		
77	18.49	328	1.55	11752	1 8 .		
68	20.96	370	1.43	11752	2 0 .		
64	22.40	362	1.60	11752	2 2 .		
57	25.11	403	1.47	11752	2 5 .		
51	28.18	451	1.35	11715	2 8 .		
43	33.48	583	1.07	11544	3 2 .		
40	35.79	563	1.13	11615	3 6 .		
35	40.57	634	1.03	11600	C 0 6 2 1 4 0 _ M _ _ _ 3 . 0 A - -	53	100L
30	47.32	815	0.85	11400	4 5 .		
130	10.94	201	3.64	24654	C 0 7 2 1 1 1 _ M _ _ _ 3 . 0 A - -	95	100L
116	12.29	227	3.37	25318	1 2 .		
105	13.52	249	3.19	25990	1 4 .		
90	15.80	279	2.56	27218	1 6 .		
81	17.66	323	2.72	27800	1 8 .		
71	20.07	367	2.51	28732	2 0 .		
65	21.89	385	2.03	28898	2 2 .		
58	24.59	430	1.86	28943	2 5 .		
53	27.03	473	1.74	29018	2 8 .		
46	30.81	554	1.43	28530	3 2 .		
40	35.31	611	1.42	29151	3 6 .		
35	40.15	691	1.29	29151	4 0 .		
32	44.13	785	1.11	29051	4 5 .		
29	49.90	883	1.00	29051	5 0 .		
27	53.62	913	1.04	29057	5 6 .		
23	61.62	1042	0.93	28986	6 3 .		
58	24.47	434	3.80	38856	C 0 8 2 1 2 5 _ M _ _ _ 3 . 0 A - -	145	100L
52	27.22	480	3.54	39518	2 8 .		
45	31.78	577	3.37	40736	3 2 .		
40	35.20	618	2.91	41500	3 6 .		
36	39.51	690	2.67	41563	4 0 .		
33	43.64	785	2.76	40657	4 5 .		
29	49.26	881	2.55	41512	5 0 .		
26	54.60	942	2.08	41884	5 6 .		
22	63.56	1087	1.85	41869	6 3 .		
20	69.64	1229	2.02	41794	7 1 .		
19	76.50	1349	1.90	41758	8 0 .		
16	87.29	1474	1.44	41801	9 0 .		
14	98.53	1652	1.31	41828	1 0 0		
14	102.38	1788	1.54	41828	1 1 2		
12	117.89	2042	1.40	41757	1 2 5		
10	139.29	2296	1.01	41686	1 4 0		
9.3	153.00	2517	0.93	41700	1 6 0		
9.1	156.45	2570	1.06	41656	C 0 8 4 1 1 6 0 _ M _ _ _ 3 . 0 A - -	161	100L
8.1	176.60	2887	0.99	41656	1 8 0		
20	69.91	1250	3.41	53723	C 0 9 2 1 7 1 _ M _ _ _ 3 . 0 A - -	208	100L
18	77.18	1380	3.12	53704	8 0 .		
15	93.18	1578	2.98	53684	9 0 .		
14	103.53	1745	2.78	53665	1 0 0		
13	106.17	1877	2.37	53681	1 1 2		
12	119.38	2098	2.14	53651	1 2 5		
10	146.23	2417	2.19	53621	1 4 0		
8.8	161.44	2660	2.04	53592	1 6 0		
6.4	222.08	3593	1.55	53497	2 1 2		
5.7	249.73	4007	1.39	53454	2 5 0		
8.9	159.68	2681	1.78	53383	C 0 9 4 1 1 6 0 _ M _ _ _ 3 . 0 A - -	229	100L
8.0	177.41	2966	1.62	53383	1 8 0		
6.3	224.51	3769	1.27	53383	2 1 2		
5.7	249.43	4169	1.16	53383	2 5 0		
5.0	282.46	4739	1.01	53383	2 8 0		
4.5	313.81	5243	0.92	53383	3 1 5		

NOTE:
Other output speeds are available using 2 & 8 pole motors. Please contact our Application Engineers

SERIES C SELECTION TABLE GEARED MOTORS

3.0 kW
4 POLE

3.0 kW
6 POLE

N2 RPM	i	M2 Nm	Fm	N	Unit Designation	kg	
Output Speed	Ratio	Output Torque	Service Factor	Overhung Load	Column Entry 1 - 20 Spaces to be filled when entering order	Weight of Base Mount unit	Motor Size
12	115.82	2064	3.87	87400	C 1 0 2 1 1 2 5 _ M _ _ _ 3 . 0 A - -	305	100L
10	144.71	2462	3.15	87381	1 4 0		
8.5	166.73	2818	2.82	87372	1 6 0		
6.3	225.50	3757	2.23	87369	2 1 2		
5.9	242.27	4021	2.11	87369	2 5 0		
2.9	495.31	8361	1.01	87299	C 1 0 4 1 5 0 0 _ M _ _ _ 3 . 0 A - -	347	100L
2.6	544.84	9194	0.92	87299	5 6 0		
2.3	626.07	10557	0.80	87299	6 3 0		
116	8.23	221	1.99	11846	C 0 6 2 1 8 . 0 _ M _ _ _ 3 . 0 C - -	82	132S
83	11.57	307	1.62	11794	1 1 .		
74	12.97	343	1.51	11743	1 2 .		
66	14.56	384	1.40	11692	1 4 .		
60	15.93	384	1.52	11743	1 6 .		
52	18.49	484	1.21	11641	1 8 .		
46	20.96	547	1.12	11589	2 0 .		
43	22.40	530	1.18	11641	2 2 .		
38	25.11	590	1.08	11589	2 5 .		
34	28.18	657	0.99	11565	2 8 .		
29	33.48	862	0.82	11320	3 2 .		
27	35.79	820	0.84	11392	3 6 .		
121	7.90	217	2.83	24578	C 0 7 2 1 8 . 0 _ M _ _ _ 3 . 0 C - -	126	132S
87	10.94	300	2.83	26605	1 1 .		
78	12.29	336	2.66	27425	1 2 .		
71	13.52	369	2.51	28125	1 4 .		
60	15.80	414	1.92	28725	1 6 .		
54	17.66	479	2.13	28575	1 8 .		
48	20.07	539	1.96	28700	2 0 .		
44	21.89	568	1.51	29125	2 2 .		
39	24.59	635	1.39	29125	2 5 .		
35	27.03	696	1.29	29125	2 8 .		
31	30.81	818	1.05	29046	3 2 .		
27	35.31	899	1.05	29080	3 6 .		
24	40.15	1016	0.95	29020	4 0 .		
22	44.13	1159	0.82	28982	4 5 .		
61	15.54	414	3.91	37968	C 0 8 2 1 1 6 . _ M _ _ _ 3 . 0 C - -	169	132S
54	17.60	479	3.81	38900	1 8 .		
48	19.76	538	3.55	40105	2 0 .		
43	22.03	581	3.06	41142	2 2 .		
39	24.47	643	2.83	41252	2 5 .		
35	27.22	711	2.61	41675	2 8 .		
30	31.78	850	2.62	41575	3 2 .		
27	35.20	908	2.15	41875	3 6 .		
24	39.51	1015	1.96	41850	4 0 .		
22	43.64	1160	2.12	41826	4 5 .		
19	49.26	1302	1.95	41752	5 0 .		
17	54.60	1382	1.52	41825	5 6 .		
15	63.56	1596	1.35	41787	6 3 .		
14	69.64	1818	1.53	41694	7 1 .		
12	76.50	1991	1.43	41694	8 0 .		
11	87.29	2164	1.06	41755	9 0 .		
10	98.53	2433	0.96	41700	1 0 0		
9.3	102.38	2642	1.15	41700	1 1 2		
21	44.55	1195	3.55	53734	C 0 9 2 1 4 5 . _ M _ _ _ 3 . 0 C - -	232	132S
19	49.49	1326	3.23	53712	5 0 .		
14	69.91	1849	2.40	53666	7 1 .		
12	77.18	2037	2.20	53633	8 0 .		
10	93.18	2310	2.27	53600	9 0 .		
9.2	103.53	2555	2.11	53566	1 0 0		
9.0	106.17	2774	1.66	53563	1 1 2		
8.0	119.38	3095	1.50	53515	1 2 5		
6.5	146.23	3542	1.58	53468	1 4 0		
5.9	161.44	3895	1.43	53421	1 6 0		
4.3	222.08	5258	1.06	53246	2 1 2		
3.8	249.73	5883	0.95	53176	2 5 0		
6.0	159.68	4010	1.19	53383	C 0 9 4 1 1 6 0 _ M _ _ _ 3 . 0 C - -	260	132S
5.4	177.41	4437	1.09	53383	1 8 0		
4.3	224.51	5634	0.85	53383	2 1 2		
10	91.32	2328	3.30	87384	C 1 0 2 1 9 0 . _ M _ _ _ 3 . 0 C - -	329	132S
9.4	101.47	2575	3.04	87368	1 0 0		
8.9	107.80	2836	3.07	87400	1 1 2		
8.2	115.82	3038	2.60	87400	1 2 5		
6.6	144.71	3619	2.30	87350	1 4 0		
5.7	166.73	4144	2.06	87325	1 6 0		
4.2	225.50	5513	1.60	87287	2 1 2		
3.9	242.27	5897	1.50	87287	2 5 0		

NOTE:
Other output speeds are available using 2 & 8 pole motors. Please contact our Application Engineers

SERIES C

SELECTION TABLE

GEARED MOTORS

3.0 kW
6 POLE

4.0 kW
4 POLE

N2 RPM	i	M2 Nm	Fm	N	Unit Designation	kg			
Output Speed	Ratio	Output Torque	Service Factor	Overhung Load	Column Entry 1 - 20 Spaces to be filled when entering order	Weight of Base Mount unit	Motor Size		
5.9	160.55	4062	2.09	87299	C 1 0 4 1 1 6 0 _ M _ - _ _ 3 . 0 C - -	378	132S		
5.4	178.41	4494	1.84	87375	1 8 0				
4.3	222.38	5623	1.51	87299	2 1 2				
3.9	247.12	6221	1.33	87375	2 5 0				
3.5	274.67	6942	1.22	87299	2 8 0				
3.1	305.22	7680	1.08	87375	3 1 5				
2.7	358.77	9058	0.94	87299	3 6 0				
2.3	407.90	10293	0.82	87299	4 0 0				
173	8.31	192	1.09	7440	C 0 5 2 1 8 . 0 _ M _ - _ _ 4 . 0 A - -	49	112M		
123	11.66	265	0.90	7440	1 1 .				
112	12.85	291	0.85	7440	1 2 .				
174	8.23	197	1.89	11851	C 0 6 2 1 8 . 0 _ M _ - _ _ 4 . 0 A - -	65	112M		
124	11.57	275	1.55	11801	1 1 .				
111	12.97	308	1.45	11801	1 2 .				
99	14.56	344	1.35	11721	1 4 .				
90	15.93	346	1.49	11790	1 6 .				
78	18.49	435	1.17	11651	1 8 .				
68	20.96	491	1.08	11651	2 0 .				
64	22.40	480	1.20	11651	2 2 .				
57	25.11	534	1.11	11651	2 5 .				
51	28.18	597	1.02	11600	2 8 .				
43	33.48	772	0.81	11400	3 2 .				
40	35.79	746	0.85	11500	3 6 .				
182	7.90	193	3.19	22778	C 0 7 2 1 8 . 0 _ M _ - _ _ 4 . 0 A - -			109	112M
131	10.94	267	2.75	24347	1 1 .				
117	12.29	301	2.55	24965	1 2 .				
106	13.52	329	2.41	25604	1 4 .				
91	15.80	370	1.93	26865	1 6 .				
81	17.66	428	2.05	27300	1 8 .				
71	20.07	485	1.90	28147	2 0 .				
66	21.89	509	1.53	28520	2 2 .				
58	24.59	570	1.41	28622	2 5 .				
53	27.03	626	1.31	28792	2 8 .				
47	30.81	734	1.08	28256	3 2 .				
41	35.31	810	1.08	29090	3 6 .				
36	40.15	915	0.98	29090	4 0 .				
33	44.13	1039	0.84	28990	4 5 .				
92	15.54	369	3.76	34793	C 0 8 2 1 1 6 . _ M _ - _ _ 4 . 0 A - -	152	112M		
82	17.60	431	3.66	35596	1 8 .				
73	19.76	483	3.41	36798	2 0 .				
65	22.03	519	3.04	37796	2 2 .				
59	24.47	574	2.87	38426	2 5 .				
53	27.22	636	2.67	39040	2 8 .				
45	31.78	765	2.55	40031	3 2 .				
41	35.20	819	2.20	41000	3 6 .				
36	39.51	913	2.01	41143	4 0 .				
33	43.64	1040	2.09	40150	4 5 .				
29	49.26	1167	1.93	41353	5 0 .				
26	54.60	1247	1.57	41866	5 6 .				
23	63.56	1440	1.40	41832	6 3 .				
21	69.64	1628	1.53	41751	7 1 .				
19	76.50	1787	1.43	41701	8 0 .				
16	87.29	1951	1.09	41760	9 0 .				
15	98.53	2188	0.99	41800	1 0 0				
14	102.38	2368	1.17	41800	1 1 2				
12	117.89	2704	1.05	41700	1 2 5				
32	44.55	1071	3.76	53733	C 0 9 2 1 4 5 . _ M _ - _ _ 4 . 0 A - -	215	112M		
29	49.49	1189	3.44	53716	5 0 .				
21	69.91	1655	2.57	53682	7 1 .				
19	77.18	1827	2.35	53653	8 0 .				
15	93.18	2089	2.25	53624	9 0 .				
14	103.53	2311	2.10	53594	1 0 0				
14	106.17	2485	1.79	53618	1 1 2				
12	119.38	2779	1.62	53573	1 2 5				
10	146.23	3200	1.65	53528	1 4 0				
8.9	161.44	3521	1.54	53482	1 6 0				
6.5	222.08	4758	1.17	53338	2 1 2				
5.7	249.73	5306	1.05	53272	2 5 0				
9.0	159.68	3550	1.35	53383	C 0 9 4 1 1 6 0 _ M _ - _ _ 4 . 0 A - -	243	112M		
8.1	177.41	3927	1.23	53383	1 8 0				
6.4	224.51	4990	0.96	53383	2 1 2				
5.8	249.43	5519	0.87	53383	2 5 0				
16	91.32	2100	3.39	87400	C 1 0 2 1 9 0 . _ M _ - _ _ 4 . 0 A - -	312	112M		
14	101.47	2322	3.12	87385	1 0 0				
13	107.80	2551	3.39	87400	1 1 2				
12	115.82	2733	2.92	87400	1 2 5				
10	144.71	3260	2.38	87359	1 4 0				
8.6	166.73	3732	2.13	87338	1 6 0				
6.4	225.50	4974	1.68	87332	2 1 2				
5.9	242.27	5324	1.59	87332	2 5 0				

NOTE:
Other output speeds are available using 2 & 8 pole motors. Please contact our Application Engineers

SERIES C SELECTION TABLE GEARED MOTORS

4.0 kW
4 POLE

4.0 kW
6 POLE

N2 RPM	i	M2 Nm	Fm	N	Unit Designation	kg	
Output Speed	Ratio	Output Torque	Service Factor	Overhung Load	Column Entry 1 - 20 Spaces to be filled when entering order	Weight of Base Mount unit	Motor Size
8.9	160.55	3596	2.36	87299	C 1 0 4 1 1 6 0 _ M _ _ _ 4 . 0 A _ _	361	112M
8.0	178.41	3976	2.08	87375	1 8 0		
6.5	222.38	4979	1.70	87299	2 1 2		
5.8	247.12	5507	1.51	87375	2 5 0		
5.2	274.67	6149	1.38	87299	2 8 0		
4.7	305.22	6800	1.22	87375	3 1 5		
4.0	358.77	8027	1.06	87299	3 6 0		
3.5	407.90	9123	0.93	87299	4 0 0		
3.2	453.27	10090	0.82	87375	4 5 0		
117	8.23	293	1.5	11787	C 0 6 2 1 8 . 0 _ M _ _ _ 4 . 0 C _ _	86	132M
83	11.57	408	1.22	11716	1 1 .		
74	12.97	456	1.14	11646	1 2 .		
66	14.56	510	1.06	11575	1 4 .		
60	15.93	509	1.14	11646	1 6 .		
52	18.49	643	0.91	11504	1 8 .		
46	20.96	726	0.84	11433	2 0 .		
43	22.40	703	0.89	11504	2 2 .		
38	25.11	782	0.81	11433	2 5 .		
122	7.90	288	2.13	24231	C 0 7 2 1 8 . 0 _ M _ _ _ 4 . 0 C _ _	130	132M
88	10.94	398	2.13	26142	1 1 .		
78	12.29	446	2.01	26908	1 2 .		
71	13.52	489	1.89	27541	1 4 .		
61	15.80	550	1.45	28408	1 6 .		
54	17.66	635	1.61	28158	1 8 .		
48	20.07	716	1.48	28366	2 0 .		
44	21.89	754	1.14	29075	2 2 .		
39	24.59	843	1.04	29075	2 5 .		
36	27.03	923	0.97	29075	2 8 .		
87	11.01	405	3.83	33852	C 0 8 2 1 1 1 . _ M _ _ _ 4 . 0 C _ _	173	132M
78	12.24	447	3.60	34773	1 2 .		
71	13.61	494	3.38	35768	1 4 .		
62	15.54	549	2.95	37547	1 6 .		
55	17.60	636	2.88	38300	1 8 .		
49	19.76	714	2.67	39442	2 0 .		
44	22.03	771	2.31	40636	2 2 .		
39	24.47	853	2.13	40821	2 5 .		
35	27.22	944	1.97	41525	2 8 .		
30	31.78	1127	1.98	41358	3 2 .		
27	35.20	1205	1.62	41858	3 6 .		
24	39.51	1346	1.48	41816	4 0 .		
22	43.64	1539	1.60	41798	4 5 .		
19	49.26	1727	1.47	41696	5 0 .		
18	54.60	1834	1.14	41775	5 6 .		
15	63.56	2118	1.01	41712	6 3 .		
14	69.64	2412	1.15	41616	7 1 .		
13	76.50	2641	1.08	41616	8 0 .		
22	44.55	1585	2.67	53704	C 0 9 2 1 4 5 . _ M _ _ _ 4 . 0 C _ _	236	132M
19	49.49	1760	2.44	53673	5 0 .		
14	69.91	2453	1.81	53607	7 1 .		
12	77.18	2702	1.66	53559	8 0 .		
10	93.18	3064	1.71	53511	9 0 .		
9.3	103.53	3388	1.59	53462	1 0 0		
9.0	106.17	3680	1.25	53457	1 1 2		
8.0	119.38	4105	1.13	53389	1 2 5		
6.6	146.23	4698	1.19	53321	1 4 0		
5.9	161.44	5166	1.08	53252	1 6 0		
4.3	222.08	6975	0.80	53000	2 1 2		
6.0	159.68	5319	0.90	53383	C 0 9 4 1 1 6 0 _ M _ _ _ 4 . 0 C _ _	264	132M
5.4	177.41	5885	0.82	53383	1 8 0		
14	69.18	2448	3.53	87362	C 1 0 2 1 7 1 . _ M _ _ _ 4 . 0 C _ _	333	132M
12	79.71	2819	3.10	87400	8 0 .		
11	91.32	3088	2.49	87373	9 0 .		
9.5	101.47	3416	2.30	87347	1 0 0		
8.9	107.80	3762	2.31	87400	1 1 2		
8.3	115.82	4030	1.96	87400	1 2 5		
6.6	144.71	4801	1.74	87316	1 4 0		
5.8	166.73	5496	1.55	87275	1 6 0		
4.3	225.50	7312	1.21	87212	2 1 2		
4.0	242.27	7822	1.13	87212	2 5 0		
6.0	160.55	5388	1.57	87299	C 1 0 4 1 1 6 0 _ M _ _ _ 4 . 0 C _ _	382	132M
5.4	178.41	5960	1.39	87375	1 8 0		
4.3	222.38	7459	1.14	87299	2 1 2		
3.9	247.12	8252	1.00	87375	2 5 0		
3.5	274.67	9208	0.92	87299	2 8 0		
3.1	305.22	10187	0.81	87375	3 1 5		

NOTE:
Other output speeds are available using 2 & 8 pole motors. Please contact our Application Engineers

SERIES C SELECTION TABLE GEARED MOTORS

5.5 kW
4 POLE

N2 RPM	i	M2 Nm	Fm	N	Unit Designation	kg	
Output Speed	Ratio	Output Torque	Service Factor	Overhung Load	Column Entry 1 - 20 Spaces to be filled when entering order	Weight of Base Mount unit	Motor Size
175	8.23	270	1.38	11786	C 0 6 2 1 8 . 0 _ M _ - _ _ 5 . 5 A -	82	132S
124	11.57	377	1.13	11715	1 1 .		
111	12.97	422	1.06	11715	1 2 .		
99	14.56	472	0.99	11600	1 4 .		
90	15.93	474	1.09	11700	1 6 .		
78	18.49	596	0.85	11500	1 8 .		
64	22.40	658	0.88	11500	2 2 .		
57	25.11	732	0.81	11500	2 5 .		
182	7.90	265	2.33	22426	C 0 7 2 1 8 . 0 _ M _ - _ _ 5 . 5 A -	126	132S
132	10.94	366	2.00	23887	1 1 .		
117	12.29	412	1.86	24437	1 2 .		
107	13.52	452	1.76	25025	1 4 .		
91	15.80	507	1.41	26337	1 6 .		
82	17.66	587	1.50	26550	1 8 .		
72	20.07	665	1.38	27269	2 0 .		
66	21.89	698	1.12	27954	2 2 .		
59	24.59	781	1.03	28141	2 5 .		
53	27.03	858	0.96	28452	2 8 .		
131	11.01	371	3.56	31175	C 0 8 2 1 1 1 . _ M _ - _ _ 5 . 5 A -	169	132S
118	12.24	413	3.34	31897	1 2 .		
106	13.61	457	3.12	32868	1 4 .		
93	15.54	506	2.74	34371	1 6 .		
82	17.60	591	2.67	35010	1 8 .		
73	19.76	662	2.49	36130	2 0 .		
65	22.03	711	2.22	37210	2 2 .		
59	24.47	787	2.09	37782	2 5 .		
53	27.22	871	1.95	38325	2 8 .		
45	31.78	1048	1.86	38975	3 2 .		
41	35.20	1122	1.60	40250	3 6 .		
36	39.51	1251	1.47	40512	4 0 .		
33	43.64	1425	1.52	39389	4 5 .		
29	49.26	1599	1.41	41116	5 0 .		
26	54.60	1709	1.15	41837	5 6 .		
23	63.56	1973	1.02	41775	6 3 .		
21	69.64	2231	1.12	41686	7 1 .		
19	76.50	2448	1.05	41615	8 0 .		
32	44.55	1468	2.74	53698	C 0 9 2 1 4 5 . _ M _ - _ _ 5 . 5 A -	232	132S
29	49.49	1629	2.51	53673	5 0 .		
21	69.91	2268	1.88	53622	7 1 .		
19	77.18	2504	1.72	53577	8 0 .		
15	93.18	2863	1.64	53533	9 0 .		
14	103.53	3167	1.53	53488	1 0 0		
14	106.17	3405	1.30	53525	1 1 2		
12	119.38	3808	1.18	53456	1 2 5		
10	146.23	4385	1.21	53387	1 4 0		
8.9	161.44	4825	1.12	53318	1 6 0		
6.5	222.08	6519	0.86	53100	2 1 2		
9.0	159.68	4865	0.98	53383	C 0 9 4 1 1 6 0 _ M _ - _ _ 5 . 5 A -	260	132S
8.1	177.41	5381	0.90	53383	1 8 0		
21	69.18	2272	3.34	85716	C 1 0 2 1 7 1 . _ M _ - _ _ 5 . 5 A -	329	132S
18	79.71	2606	2.94	86407	8 0 .		
16	91.32	2878	2.47	87400	9 0 .		
14	101.47	3182	2.28	87374	1 0 0		
13	107.80	3496	2.47	87400	1 1 2		
12	115.82	3745	2.13	87400	1 2 5		
10	144.71	4467	1.74	87325	1 4 0		
8.6	166.73	5114	1.56	87287	1 6 0		
6.4	225.50	6816	1.23	87275	2 1 2		
5.9	242.27	7295	1.16	87275	2 5 0		
9.0	160.55	4927	1.72	87299	C 1 0 4 1 1 6 0 _ M _ - _ _ 5 . 5 A -	378	132S
8.1	178.41	5449	1.52	87375	1 8 0		
6.5	222.38	6823	1.24	87299	2 1 2		
5.8	247.12	7545	1.10	87375	2 5 0		
5.2	274.67	8425	1.01	87299	2 8 0		
4.7	305.22	9318	0.89	87375	3 1 5		

NOTE:
Other output speeds are available using 2 & 8 pole motors. Please contact our Application Engineers

SERIES C SELECTION TABLE GEARED MOTORS

5.5 kW
6 POLE

N2 RPM	i	M2 Nm	Fm	N	Unit Designation	kg	
Output Speed	Ratio	Output Torque	Service Factor	Overhung Load	Column Entry 1 - 20 Spaces to be filled when entering order	Weight of Base Mount unit	Motor Size
117	8.23	403	1.09	11700	C 0 6 2 1 8 . 0 _ M _ _ _ 5 . 5 C - -	86	132M
83	11.57	561	0.89	11600	1 1 .		
74	12.97	627	0.83	11500	1 2 .		
60	15.93	700	0.83	11500	1 6 .		
122	7.90	396	1.55	23710	C 0 7 2 1 8 . 0 _ M _ _ _ 5 . 5 C - -	130	132M
88	10.94	547	1.55	25447	1 1 .		
78	12.29	613	1.46	26133	1 2 .		
71	13.52	673	1.38	26666	1 4 .		
61	15.80	756	1.05	27933	1 6 .		
54	17.66	873	1.17	27533	1 8 .		
48	20.07	984	1.08	27866	2 0 .		
44	21.89	1037	0.83	29000	2 2 .		
124	7.77	391	3.16	30947	C 0 8 2 1 8 . 0 _ M _ _ _ 5 . 5 C - -	173	132M
87	11.01	557	2.78	33284	1 1 .		
78	12.24	614	2.62	34157	1 2 .		
71	13.61	680	2.45	35089	1 4 .		
62	15.54	755	2.15	36915	1 6 .		
55	17.60	875	2.09	37400	1 8 .		
49	19.76	981	1.95	38447	2 0 .		
44	22.03	1060	1.68	39878	2 2 .		
39	24.47	1173	1.55	40173	2 5 .		
35	27.22	1298	1.43	41300	2 8 .		
30	31.78	1550	1.44	41033	3 2 .		
27	35.20	1657	1.18	41833	3 6 .		
24	39.51	1851	1.07	41766	4 0 .		
22	43.64	2117	1.16	41756	4 5 .		
19	49.26	2375	1.07	41612	5 0 .		
18	54.60	2521	0.83	41700	5 6 .		
14	69.64	3316	0.84	41500	7 1 .		
22	44.55	2179	1.95	53660	C 0 9 2 1 4 5 . _ M _ _ _ 5 . 5 C - -	236	132M
19	49.49	2420	1.77	53614	5 0 .		
14	69.91	3372	1.32	53518	7 1 .		
12	77.18	3716	1.21	53448	8 0 .		
10	93.18	4213	1.24	53377	9 0 .		
9.3	103.53	4659	1.15	53307	1 0 0		
9.0	106.17	5060	0.91	53300	1 1 2		
8.0	119.38	5645	0.82	53200	1 2 5		
6.6	146.23	6461	0.86	53100	1 4 0		
22	43.65	2160	3.76	85776	C 1 0 2 1 4 5 . _ M _ _ _ 5 . 5 C - -	333	132M
20	48.51	2395	3.47	86058	5 0 .		
14	69.18	3366	2.56	87340	7 1 .		
12	79.71	3876	2.25	87400	8 0 .		
11	91.32	4246	1.81	87357	9 0 .		
9.5	101.47	4697	1.67	87315	1 0 0		
8.9	107.80	5172	1.68	87400	1 1 2		
8.3	115.82	5542	1.43	87400	1 2 5		
6.6	144.71	6601	1.26	87266	1 4 0		
5.8	166.73	7558	1.13	87200	1 6 0		
4.3	225.50	10054	0.88	87100	2 1 2		
4.0	242.27	10756	0.82	87100	2 5 0		
6.0	160.55	7408	1.14	87299	C 1 0 4 1 1 6 0 _ M _ _ _ 5 . 5 C - -	382	132M
5.4	178.41	8196	1.01	87375	1 8 0		
4.3	222.38	10256	0.83	87299	2 1 2		
176	8.23	367	1.01	11700	C 0 6 2 1 8 . 0 _ M _ _ _ 7 . 5 A - -	86	132M
125	11.57	513	0.83	11600	1 1 .		
183	7.90	360	1.71	21957	C 0 7 2 1 8 . 0 _ M _ _ _ 7 . 5 A - -	130	132M
132	10.94	497	1.47	23273	1 1 .		
118	12.29	561	1.37	23732	1 2 .		
107	13.52	614	1.30	24252	1 4 .		
91	15.80	689	1.04	25632	1 6 .		
82	17.66	797	1.10	25550	1 8 .		
72	20.07	904	1.02	26100	2 0 .		
66	21.89	949	0.82	27200	2 2 .		
186	7.77	355	3.20	28647	C 0 8 2 1 8 . 0 _ M _ _ _ 7 . 5 A - -	173	132M
131	11.01	504	2.62	30675	1 1 .		
118	12.24	561	2.46	31350	1 2 .		
106	13.61	622	2.30	32243	1 4 .		
93	15.54	688	2.02	33809	1 6 .		
82	17.60	803	1.97	34229	1 8 .		
73	19.76	899	1.83	35239	2 0 .		
66	22.03	966	1.63	36429	2 2 .		
59	24.47	1070	1.54	36922	2 5 .		
53	27.22	1184	1.44	37370	2 8 .		
45	31.78	1424	1.37	37565	3 2 .		
41	35.20	1525	1.18	39250	3 6 .		
37	39.51	1701	1.08	39671	4 0 .		
33	43.64	1937	1.12	38375	4 5 .		
29	49.26	2173	1.04	40800	5 0 .		
26	54.60	2322	0.84	41800	5 6 .		
21	69.64	3032	0.82	41600	7 1 .		

7.5 kW
4 POLE

NOTE:
Other output speeds are available using 2 & 8 pole motors. Please contact our Application Engineers

SERIES C SELECTION TABLE GEARED MOTORS

7.5 kW

4 POLE

N2 RPM	i	M2 Nm	Fm	N	Unit Designation	kg	
Output Speed	Ratio	Output Torque	Service Factor	Overhung Load	Column Entry 1 - 20 Spaces to be filled when entering order	Weight of Base Mount unit	Motor Size
32	44.55	1995	2.02	53652	C 0 9 2 1 4 5 . _ M _ - _ _ 7 . 5 A - -	236	132M
29	49.49	2214	1.85	53616	5 0 .		
21	69.91	3082	1.38	53541	7 1 .		
19	77.18	3402	1.26	53476	8 0 .		
16	93.18	3891	1.21	53412	9 0 .		
14	103.53	4304	1.13	53347	C 0 9 2 1 1 0 0 _ M _ - _ _ 7 . 5 A - -	236	132M
14	106.17	4628	0.96	53400	1 1 2		
12	119.38	5174	0.87	53300	1 2 5		
10	146.23	5959	0.89	53200	1 4 0		
9.0	161.44	6557	0.83	53100	1 6 0		
33	43.65	1975	3.61	82939	C 1 0 2 1 4 5 . _ M _ - _ _ 7 . 5 A - -	333	132M
30	48.51	2188	3.32	83701	5 0 .		
21	69.18	3087	2.46	84696	7 1 .		
18	79.71	3541	2.17	85806	8 0 .		
16	91.32	3911	1.82	87400	9 0 .		
14	101.47	4324	1.67	87358	1 0 0		
13	107.80	4751	1.82	87400	1 1 2		
12	115.82	5089	1.57	87400	1 2 5		
10	144.71	6070	1.28	87279	1 4 0		
8.7	166.73	6949	1.15	87219	1 6 0		
6.4	225.50	9263	0.90	87200	2 1 2		
6.0	242.27	9913	0.85	87200	2 5 0		
9.0	160.55	6696	1.27	87299	C 1 0 4 1 1 6 0 _ M _ - _ _ 7 . 5 A -	-382	132M
8.1	178.41	7404	1.12	87375	1 8 0		
6.5	222.38	9272	0.91	87299	2 1 2		
5.8	247.12	10254	0.81	87375	2 5 0		

7.5 kW

6 POLE

122	7.90	540	1.14	23015	C 0 7 2 1 8 . 0 _ M _ - _ _ 7 . 5 C - -	159	160M
88	10.94	746	1.14	24521	1 1 .		
78	12.29	836	1.07	25100	1 2 .		
71	13.52	918	1.01	25500	1 4 .		
54	17.66	1191	0.86	26700	1 8 .		
124	7.77	534	2.32	30421	C 0 8 2 1 8 . 0 _ M _ - _ _ 7 . 5 C - -	202	160M
87	11.01	759	2.04	32526	1 1 .		
78	12.24	838	1.92	33336	1 2 .		
71	13.61	927	1.80	34184	1 4 .		
62	15.54	1029	1.57	36073	1 6 .		
55	17.60	1193	1.53	36200	1 8 .		
49	19.76	1338	1.43	37121	2 0 .		
44	22.03	1446	1.23	38868	2 2 .		
39	24.47	1600	1.14	39310	2 5 .		
35	27.22	1770	1.05	41000	2 8 .		
30	31.78	2114	1.05	40600	3 2 .		
27	35.20	2260	0.86	41800	3 6 .		
22	43.64	2887	0.85	41700	4 5 .		
87	10.98	760	3.73	51500	C 0 9 2 1 1 1 . _ M _ - _ _ 7 . 5 C - -	265	160M
78	12.30	850	3.49	52800	1 2 .		
70	13.81	952	3.25	53800	1 4 .		
58	16.68	1108	2.73	53800	1 6 .		
54	17.79	1220	2.79	53800	1 8 .		
48	19.88	1357	2.60	53800	2 0 .		
42	22.96	1513	2.25	53800	2 2 .		
37	25.73	1685	2.11	53800	2 5 .		
33	28.89	1887	1.96	53800	2 8 .		
31	31.43	2119	1.92	53800	3 2 .		
26	37.22	2398	1.68	53800	3 6 .		
23	41.59	2679	1.56	53700	4 0 .		
22	44.55	2971	1.43	53602	4 5 .		
19	49.49	3300	1.30	53536	5 0 .		
17	57.66	3647	1.27	53600	5 6 .		
15	65.74	4129	1.16	53500	6 3 .		
14	69.91	4599	0.97	53400	7 1 .		
12	77.18	5067	0.88	53300	8 0 .		
10	93.18	5745	0.91	53200	9 0 .		
9.3	103.53	6354	0.85	53100	1 0 0		
41	23.23	1554	3.84	79500	C 1 0 2 1 2 2 . _ M _ - _ _ 7 . 5 C - -	362	160M
38	25.27	1682	3.61	81400	2 5 .		
33	28.70	1902	3.28	84200	2 8 .		
30	31.85	2167	3.40	85000	3 2 .		
26	37.38	2463	2.67	87400	3 6 .		
24	40.36	2642	2.52	87400	4 0 .		
22	43.65	2945	2.76	84964	4 5 .		
20	48.51	3267	2.55	85388	5 0 .		
16	58.85	3798	1.87	87400	5 6 .		
14	66.62	4303	1.68	87400	6 3 .		
14	69.18	4590	1.88	87311	7 1 .		
12	79.71	5286	1.65	87400	8 0 .		
11	91.32	5790	1.33	87336	9 0 .		

NOTE:

Other output speeds are available using 2 & 8 pole motors. Please contact our Application Engineers

SERIES C SELECTION TABLE GEARED MOTORS

7.5 kW
6 POLE

11.0 kW
4 POLE

N2 RPM	i	M2 Nm	Fm	N	Unit Designation	kg			
Output Speed	Ratio	Output Torque	Service Factor	Overhung Load	Column Entry 1 - 20 Spaces to be filled when entering order	Weight of Base Mount unit	Motor Size		
9.5	101.47	6405	1.22	87273	C 1 0 2 1 1 0 0 _ M _ - _ - _ 7 . 5 C - -	362	160M		
8.9	107.80	7054	1.23	87400	1 1 2				
8.3	115.82	7557	1.05	87400	1 2 5				
6.6	144.71	9002	0.93	87200	1 4 0				
5.8	166.73	10306	0.83	87100	1 6 0				
6.0	160.55	10103	0.84	87299	C 1 0 4 1 1 6 0 _ M _ - _ - _ 7 . 5 C - -	411	160M		
184	7.90	526	1.17	21137	C 0 7 2 1 8 . 0 _ M _ - _ - _ 1 1 . A - -	159	160M		
132	10.94	727	1.01	22200	1 1 .				
118	12.29	820	0.94	22500	1 2 .				
107	13.52	898	0.89	22900	1 4 .				
187	7.77	520	2.19	28018	C 0 8 2 1 8 . 0 _ M _ - _ - _ 1 1 . A - -			202	160M
132	11.01	737	1.79	29800	1 1 .				
119	12.24	820	1.68	30393	1 2 .				
107	13.61	909	1.57	31150	1 4 .				
93	15.54	1005	1.38	32825	1 6 .				
82	17.60	1174	1.35	32862	1 8 .				
73	19.76	1315	1.25	33681	2 0 .				
66	22.03	1413	1.12	35062	2 2 .				
59	24.47	1564	1.05	35418	2 5 .				
53	27.22	1731	0.98	35700	2 8 .				
46	31.78	2082	0.94	35100	3 2 .				
41	35.20	2229	0.81	37500	3 6 .				
182	7.97	539	3.93	44500	C 0 9 2 1 8 . 0 _ M _ - _ - _ 1 1 . A - -	265	160M		
132	10.98	741	3.26	47600	1 1 .				
118	12.30	831	3.05	48700	1 2 .				
105	13.81	928	2.85	50100	1 4 .				
87	16.68	1075	2.40	53100	1 6 .				
81	17.79	1194	2.45	53300	1 8 .				
73	19.88	1326	2.29	53800	2 0 .				
63	22.96	1473	1.98	53800	2 2 .				
56	25.73	1652	1.85	53800	2 5 .				
50	28.89	1841	1.73	53800	2 8 .				
46	31.43	2078	1.73	53800	3 2 .				
39	37.22	2355	1.48	53800	3 6 .				
35	41.59	2634	1.38	53700	4 0 .				
33	44.55	2916	1.38	53572	4 5 .				
29	49.49	3236	1.26	53515	5 0 .				
25	57.66	3601	1.13	53600	5 6 .				
22	65.74	4091	1.04	53500	6 3 .				
21	69.91	4505	0.95	53400	7 1 .				
19	77.18	4973	0.86	53300	8 0 .				
16	93.18	5687	0.83	53200	9 0 .				
62	23.23	1520	3.55	73000	C 1 0 2 1 2 2 . _ M _ - _ - _ 1 1 . A - -	362	160M		
57	25.27	1651	3.35	74000	2 5 .				
51	28.70	1869	3.05	75400	2 8 .				
46	31.85	2126	3.01	75100	3 2 .				
39	37.38	2424	2.50	79400	3 6 .				
36	40.36	2601	2.36	81000	4 0 .				
33	43.65	2887	2.47	80522	4 5 .				
30	48.51	3198	2.27	81258	5 0 .				
25	58.85	3753	1.76	87400	5 6 .				
22	66.62	4231	1.60	87400	6 3 .				
21	69.18	4512	1.68	82911	7 1 .				
18	79.71	5176	1.48	84754	8 0 .				
16	91.32	5716	1.25	87400	9 0 .				
14	101.47	6320	1.15	87331	1 0 0				
13	107.80	6945	1.25	87400	1 1 2				
13	115.82	7438	1.07	87400	1 2 5				
10	144.71	8873	0.87	87200	1 4 0				
9.0	160.55	9787	0.87	87299	C 1 0 4 1 1 6 0 _ M _ - _ - _ 1 1 . A - -	411	160M		

NOTE:
Other output speeds are available using 2 & 8 pole motors. Please contact our Application Engineers

SERIES C

SELECTION TABLE

GEARED MOTORS

11.0 kW

6 POLE

15.0 kW

4 POLE

NOTE:

Other output speeds are available using 2 & 8 pole motors. Please contact our Application Engineers

N2 RPM	i	M2 Nm	Fm	N	Unit Designation	kg	
Output Speed	Ratio	Output Torque	Service Factor	Overhung Load	Column Entry 1 - 20 Spaces to be filled when entering order	Weight of Base Mount unit	Motor Size
124	7.77	779	1.59	29500	C 0 8 2 1 8 . 0 _ M _ - _ _ 1 1 . C -	216	160L
88	11.01	1108	1.40	31200	1 1 .		
79	12.24	1223	1.32	31900	1 2 .		
71	13.61	1353	1.23	32600	C 0 8 2 1 1 4 . _ M _ - _ _ 1 1 . C -	216	160L
62	15.54	1502	1.08	34600	1 6 .		
55	17.60	1741	1.05	34100	1 8 .		
49	19.76	1953	0.98	34800	2 0 .		
44	22.03	2110	0.84	37100	2 2 .		
121	7.97	807	3.11	47360	C 0 9 2 1 8 . 0 _ M _ - _ _ 1 1 . C -	279	160L
88	10.98	1109	2.56	50348	1 1 .		
78	12.30	1240	2.39	51508	1 2 .		
70	13.81	1390	2.23	52446	1 4 .		
58	16.68	1617	1.87	53510	1 6 .		
54	17.79	1780	1.91	52931	1 8 .		
49	19.88	1980	1.78	53124	2 0 .		
42	22.96	2208	1.54	53703	2 2 .		
37	25.73	2458	1.44	53704	2 5 .		
33	28.89	2754	1.34	53672	2 8 .		
31	31.43	3092	1.32	53640	3 2 .		
26	37.22	3500	1.15	53613	3 6 .		
23	41.59	3909	1.07	53513	4 0 .		
22	44.55	4336	0.98	53500	4 5 .		
19	49.49	4814	0.89	53400	5 0 .		
17	57.66	5321	0.87	53300	5 6 .		
70	13.72	1391	3.94	67833	C 1 0 2 1 1 4 . _ M _ - _ _ 1 1 . C -	376	160L
58	16.63	1635	3.38	71873	1 6 .		
54	17.87	1802	3.34	72391	1 8 .		
50	19.29	1944	3.19	74166	2 0 .		
42	23.23	2268	2.63	78084	2 2 .		
38	25.27	2455	2.48	79860	2 5 .		
34	28.70	2775	2.25	82457	2 8 .		
30	31.85	3162	2.33	82340	3 2 .		
26	37.38	3594	1.83	85855	3 6 .		
24	40.36	3856	1.73	86144	4 0 .		
22	43.65	4297	1.89	83544	4 5 .		
20	48.51	4766	1.75	84214	5 0 .		
16	58.85	5541	1.28	87336	5 6 .		
14	66.62	6279	1.15	87353	6 3 .		
14	69.18	6697	1.29	87259	7 1 .		
12	79.71	7713	1.13	87400	8 0 .		
11	91.32	8448	0.91	87300	9 0 .		
10	101.47	9345	0.84	87200	1 0 0		
184	7.90	716	0.86	20200	C 0 7 2 1 8 . 0 _ M _ - _ _ 1 5 . A - -	173	160L
187	7.77	707	1.61	27300	C 0 8 2 1 8 . 0 _ M _ - _ _ 1 5 . A - -	216	160L
132	11.01	1001	1.32	28800	1 1 .		
119	12.24	1115	1.24	29300	1 2 .		
107	13.61	1235	1.16	29900	1 4 .		
94	15.54	1366	1.02	31700	1 6 .		
83	17.60	1595	0.99	31300	1 8 .		
74	19.76	1787	0.92	31900	2 0 .		
66	22.03	1920	0.82	33500	2 2 .		
182	7.97	733	2.89	43852	C 0 9 2 1 8 . 0 _ M _ - _ _ 1 5 . A - -	279	160L
133	10.98	1007	2.4	46717	1 1 .		
118	12.30	1130	2.25	47715	1 2 .		
105	13.81	1261	2.1	49007	1 4 .		
87	16.68	1460	1.77	52131	1 6 .		
82	17.79	1622	1.8	51889	1 8 .		
73	19.88	1803	1.69	52636	2 0 .		
63	22.96	2002	1.46	53727	2 2 .		
57	25.73	2245	1.36	53727	2 5 .		
50	28.89	2501	1.27	53727	2 8 .		
46	31.43	2824	1.27	53586	3 2 .		
39	37.22	3200	1.09	53640	3 6 .		
35	41.59	3579	1.02	53540	4 0 .		
33	44.55	3963	1.02	53480	4 5 .		
29	49.49	4398	0.93	53400	5 0 .		
25	57.66	4894	0.83	53400	5 6 .		
120	12.08	1116	3.99	60823	C 1 0 2 1 1 2 . _ M _ - _ _ 1 5 . A - -	376	160L
106	13.72	1265	3.7	62817	1 4 .		
87	16.63	1482	3.19	66523	1 6 .		
81	17.87	1640	3.16	67047	1 8 .		
75	19.29	1766	3.02	68664	2 0 .		
63	23.23	2065	2.61	71917	2 2 .		
58	25.27	2244	2.47	72823	2 5 .		
51	28.70	2540	2.25	74061	2 8 .		
46	31.85	2890	2.21	73069	3 2 .		

SERIES C SELECTION TABLE GEARED MOTORS

15.0 kW
4 POLE

15.0 kW
6 POLE

18.5 kW
4 POLE

N2 RPM	i	M2 Nm	Fm	N	Unit Designation	kg			
Output Speed	Ratio	Output Torque	Service Factor	Overhung Load	Column Entry 1 - 20 Spaces to be filled when entering order	Weight of Base Mount unit	Motor Size		
39	37.38	3294	1.84	77673	C 1 0 2 1 3 6 . _ M _ - _ _ 1 5 . A - -	376	160L		
36	40.36	3535	1.74	79147	4 0 .				
33	43.65	3923	1.82	77759	4 5 .				
30	48.51	4347	1.67	78467	5 0 .				
25	58.85	5100	1.30	85327	5 6 .				
22	66.62	5750	1.18	85945	6 3 .				
21	69.18	6132	1.24	80870	7 1 .				
18	79.71	7034	1.09	83552	8 0 .				
16	91.32	7768	0.92	87400	9 0 .				
14	101.47	8589	0.84	87300	1 0 0				
122	7.97	1095	2.29	46400	C 0 9 2 1 8 . 0 _ M _ - _ _ 1 5 . C - -			365	180L
88	10.98	1505	1.89	49033	1 1 .				
79	12.30	1682	1.76	50033	1 2 .				
70	13.81	1886	1.64	50900	1 4 .				
58	16.68	2194	1.38	53179	1 6 .				
55	17.79	2415	1.41	51937	1 8 .				
49	19.88	2687	1.31	52351	2 0 .				
42	22.96	2995	1.14	53593	2 2 .				
38	25.73	3335	1.06	53595	2 5 .				
34	28.89	3736	0.99	53527	2 8 .				
31	31.43	4195	0.97	53459	3 2 .				
26	37.22	4748	0.85	53400	3 6 .				
122	7.95	1100	3.49	59266	C 1 0 2 1 8 . 0 _ M _ - _ _ 1 5 . C - -	462	180L		
87	11.11	1533	3.30	63366	1 1 .				
80	12.08	1666	3.13	64500	1 2 .				
71	13.72	1887	2.90	66500	1 4 .				
58	16.63	2218	2.49	70700	1 6 .				
54	17.87	2445	2.47	70666	1 8 .				
50	19.29	2637	2.35	72300	2 0 .				
42	23.23	3077	1.94	76466	2 2 .				
38	25.27	3330	1.83	78100	2 5 .				
34	28.70	3765	1.66	80466	2 8 .				
30	31.85	4290	1.72	79300	3 2 .				
26	37.38	4876	1.35	84089	3 6 .				
24	40.36	5231	1.27	84710	4 0 .				
22	43.65	5830	1.39	81920	4 5 .				
20	48.51	6466	1.29	82873	5 0 .				
16	58.85	7518	0.94	87263	5 6 .				
15	66.62	8518	0.85	87300	6 3 .				
14	69.18	9086	0.95	87200	7 1 .				
184	7.97	895	2.37	43286	C 0 9 2 1 8 . 0 _ M _ - _ _ 1 8 . A - -	351	180M		
134	10.98	1230	1.97	45945	1 1 .				
119	12.30	1379	1.84	46853	1 2 .				
106	13.81	1540	1.72	48051	1 4 .				
88	16.68	1783	1.45	51284	1 6 .				
83	17.79	1980	1.47	50655	1 8 .				
74	19.88	2201	1.38	51618	2 0 .				
64	22.96	2444	1.19	53663	2 2 .				
57	25.73	2741	1.11	53663	2 5 .				
51	28.89	3054	1.04	53663	2 8 .				
47	31.43	3447	1.04	53400	3 2 .				
39	37.22	3907	0.89	53500	3 6 .				
35	41.59	4369	0.83	53400	4 0 .				
33	44.55	4838	0.83	53400	4 5 .				
132	11.11	1251	3.44	59054	C 1 0 2 1 1 1 . _ M _ - _ _ 1 8 . A - -			448	180M
122	12.08	1362	3.27	60144	1 2 .				
107	13.72	1544	3.03	62045	1 4 .				
88	16.63	1809	2.61	65844	1 6 .				
82	17.87	2002	2.59	66038	1 8 .				
76	19.29	2156	2.47	67583	2 0 .				
63	23.23	2522	2.14	70970	2 2 .				
58	25.27	2739	2.02	71794	2 5 .				
51	28.70	3101	1.84	72890	2 8 .				
46	31.85	3528	1.81	71292	3 2 .				
39	37.38	4021	1.51	76163	3 6 .				
36	40.36	4316	1.42	77526	4 0 .				

NOTE:

Other output speeds are available using 2 & 8 pole motors. Please contact our Application Engineers

SERIES C

SELECTION TABLE

GEARED MOTORS

18.5 kW
4 POLE

18.5 kW
6 POLE

22.0 kW
4 POLE

22.0 kW
6 POLE

NOTE:
Other output speeds are available using 2 & 8 pole motors. Please contact our Application Engineers

N2 RPM	i	M2 Nm	Fm	N	Unit Designation	kg			
Output Speed	Ratio	Output Torque	Service Factor	Overhung Load	Column Entry 1 - 20 Spaces to be filled when entering order	Weight of Base Mount unit	Motor Size		
34	43.65	4790	1.49	75342	C 1 0 2 1 4 5 . _ M _ - _ _ 1 8 . A - -	448	180M		
30	48.51	5306	1.37	76025	5 0 .				
25	58.85	6226	1.06	83513	5 6 .				
22	66.62	7019	0.96	84672	6 3 .				
21	69.18	7486	1.01	79085	7 1 .				
18	79.71	8586	0.89	82500	8 0 .				
122	7.97	1344	1.87	45560	C 0 9 2 1 8 . 0 _ M _ - _ _ 1 8 . C - -	423	200L		
89	10.98	1847	1.54	47882	1 1 .				
79	12.30	2064	1.44	48742	1 2 .				
71	13.81	2314	1.34	49546	1 4 .				
58	16.68	2692	1.13	52889	1 6 .				
55	17.79	2963	1.15	51068	1 8 .				
49	19.88	3297	1.07	51675	2 0 .				
42	22.96	3675	0.93	53496	2 2 .				
38	25.73	4092	0.87	53500	2 5 .				
34	28.89	4584	0.81	53400	2 8 .				
123	7.95	1350	2.84	58597	C 1 0 2 1 8 . 0 _ M _ - _ _ 1 8 . C - -	522	200L		
88	11.11	1881	2.69	62417	1 1 .				
81	12.08	2044	2.55	63473	1 2 .				
71	13.72	2316	2.37	65333	1 4 .				
59	16.63	2722	2.03	69673	1 6 .				
55	17.87	3001	2.01	69157	1 8 .				
51	19.29	3235	1.92	70666	2 0 .				
42	23.23	3775	1.58	75051	2 2 .				
39	25.27	4086	1.49	76560	2 5 .				
34	28.70	4620	1.35	78724	2 8 .				
31	31.85	5264	1.40	76640	3 2 .				
26	37.38	5983	1.10	82544	3 6 .				
24	40.36	6418	1.04	83455	4 0 .				
184	7.97	1064	1.99	42720	C 0 9 2 1 8 . 0 _ M _ - _ _ 2 2 . A - -			365	180L
134	10.98	1462	1.65	45173	1 1 .				
119	12.30	1640	1.55	45992	1 2 .				
106	13.81	1831	1.45	47096	1 4 .				
88	16.68	2120	1.22	50436	1 6 .				
83	17.79	2355	1.24	49421	1 8 .				
74	19.88	2617	1.16	50600	2 0 .				
64	22.96	2906	1.00	53600	2 2 .				
57	25.73	3260	0.94	53600	2 5 .				
51	28.89	3632	0.88	53600	2 8 .				
185	7.95	1066	3.50	54676	C 1 0 2 1 8 . 0 _ M _ - _ _ 2 2 . A - -	462	180L		
132	11.11	1488	2.89	58426	1 1 .				
122	12.08	1620	2.75	59464	1 2 .				
107	13.72	1836	2.55	61273	1 4 .				
88	16.63	2151	2.20	65164	1 6 .				
82	17.87	2381	2.18	65029	1 8 .				
76	19.29	2564	2.08	66502	2 0 .				
63	23.23	2999	1.80	70023	2 2 .				
58	25.27	3258	1.70	70764	2 5 .				
51	28.70	3687	1.55	71719	2 8 .				
46	31.85	4195	1.53	69515	3 2 .				
39	37.38	4782	1.27	74652	3 6 .				
36	40.36	5133	1.20	75905	4 0 .				
34	43.65	5696	1.25	72925	4 5 .				
30	48.51	6310	1.15	73582	5 0 .				
25	58.85	7405	0.89	81700	5 6 .				
22	66.62	8347	0.81	83400	6 3 .				
21	69.18	8903	0.85	77300	7 1 .				
122	7.97	1599	1.57	44720	C 0 9 2 1 8 . 0 _ M _ - _ _ 2 2 . C - -	423	200L		
89	10.98	2197	1.29	46731	1 1 .				
79	12.30	2455	1.21	47451	1 2 .				
71	13.81	2752	1.13	48193	1 4 .				
58	16.68	3201	0.95	52600	1 6 .				
55	17.79	3523	0.96	50200	1 8 .				
49	19.88	3921	0.90	51000	2 0 .				
123	7.95	1605	2.39	57928	C 1 0 2 1 8 . 0 _ M _ - _ _ 2 2 . C - -	522	200L		
88	11.11	2236	2.26	61468	1 1 .				
81	12.08	2431	2.15	62446	1 2 .				
71	13.72	2754	1.99	64166	1 4 .				
59	16.63	3237	1.71	68646	1 6 .				
55	17.87	3568	1.69	67648	1 8 .				
51	19.29	3848	1.61	69033	2 0 .				
42	23.23	4490	1.33	73635	2 2 .				
39	25.27	4859	1.25	75020	2 5 .				
34	28.70	5494	1.14	76982	2 8 .				
31	31.85	6260	1.18	73980	3 2 .				
26	37.38	7115	0.92	81000	3 6 .				
24	40.36	7633	0.87	82200	4 0 .				

SERIES C SELECTION TABLE GEARED MOTORS

30.0 kW
4 POLE

30.0 kW
6 POLE

37.0 kW
4 POLE

45.0 kW
4 POLE

N2 RPM	i	M2 Nm	Fm	N	Unit Designation	kg	
Output Speed	Ratio	Output Torque	Service Factor	Overhung Load	Column Entry 1 - 20 Spaces to be filled when entering order	Weight of Base Mount unit	Motor Size
184	7.97	1452	1.46	41426	C 0 9 2 1 8 . 0 _ M _ - _ _ 3 0 . A -	423	200L
134	10.98	1994	1.21	43408	1 1 .		
119	12.30	2237	1.14	44023	1 2 .		
106	13.81	2497	1.06	44911	1 4 .		
88	16.68	2891	0.89	48500	1 6 .		
83	17.79	3212	0.91	46600	1 8 .		
185	7.95	1454	2.56	53641	C 1 0 2 1 8 . 0 _ M _ - _ _ 3 0 . A -	522	200L
132	11.11	2029	2.12	56991	1 1 .		
122	12.08	2209	2.01	57911	1 2 .		
107	13.72	2504	1.87	59508	1 4 .		
88	16.63	2934	1.61	63611	1 6 .		
82	17.87	3247	1.60	62723	1 8 .		
76	19.29	3497	1.52	64032	2 0 .		
63	23.23	4089	1.32	67858	2 2 .		
58	25.27	4442	1.25	68411	2 5 .		
51	28.70	5028	1.14	69042	2 8 .		
46	31.85	5721	1.12	65453	3 2 .		
39	37.38	6520	0.93	71200	3 6 .		
36	40.36	6999	0.88	72200	4 0 .		
123	7.97	2169	1.16	42800	C 0 9 2 1 8 . 0 _ M _ - _ _ 3 0 . C -	513	225M
89	10.98	2980	0.95	44100	1 1 .		
80	12.30	3331	0.89	44500	1 2 .		
71	13.81	3733	0.83	45100	1 4 .		
123	7.95	2178	1.76	56400	C 1 0 2 1 8 . 0 _ M _ - _ _ 3 0 . C -	612	225M
88	11.11	3034	1.67	59300	1 1 .		
81	12.08	3299	1.58	60100	1 2 .		
71	13.72	3736	1.47	61500	1 4 .		
59	16.63	4392	1.26	66300	1 6 .		
55	17.87	4841	1.25	64200	1 8 .		
51	19.29	5220	1.19	65300	2 0 .		
42	23.23	6091	0.98	70400	2 2 .		
39	25.27	6593	0.92	71500	2 5 .		
34	28.70	7454	0.84	73000	2 8 .		
31	31.85	8493	0.87	67900	3 2 .		
185	7.97	1784	1.19	40294	C 0 9 2 1 8 . 0 _ M _ - _ _ 3 7 . A -	478	225S
134	10.98	2451	0.99	41864	1 1 .		
120	12.30	2749	0.92	42300	1 2 .		
107	13.81	3069	0.86	43000	1 4 .		
186	7.95	1787	2.09	52735	C 1 0 2 1 8 . 0 _ M _ - _ _ 3 7 . A -	577	225S
133	11.11	2494	1.72	55735	1 1 .		
122	12.08	2715	1.64	56552	1 2 .		
108	13.72	3078	1.52	57964	1 4 .		
89	16.63	3606	1.31	62252	1 6 .		
83	17.87	3991	1.30	60705	1 8 .		
76	19.29	4298	1.24	61870	2 0 .		
63	23.23	5026	1.07	65964	2 2 .		
58	25.27	5460	1.01	66352	2 5 .		
51	28.70	6181	0.92	66700	2 8 .		
46	31.85	7032	0.91	61900	3 2 .		
185	7.97	2170	0.98	39000	C 0 9 2 1 8 . 0 _ M _ - _ _ 4 5 . A -	513	225M
134	10.98	2982	0.81	40100	1 1 .		
186	7.95	2173	1.72	51700	C 1 0 2 1 8 . 0 _ M _ - _ _ 4 5 . A -	612	225M
133	11.11	3033	1.42	54300	1 1 .		
122	12.08	3302	1.35	55000	1 2 .		
108	13.72	3743	1.25	56200	1 4 .		
89	16.63	4386	1.08	60700	1 6 .		
83	17.87	4854	1.07	58400	1 8 .		
76	19.29	5228	1.02	59400	2 0 .		
63	23.23	6113	0.88	63800	2 2 .		
58	25.27	6641	0.83	64000	2 5 .		

NOTE:

Other output speeds are available using 2 & 8 pole motors. Please contact our Application Engineers

SERIES C

DIMENSIONS

DOUBLE REDUCTION

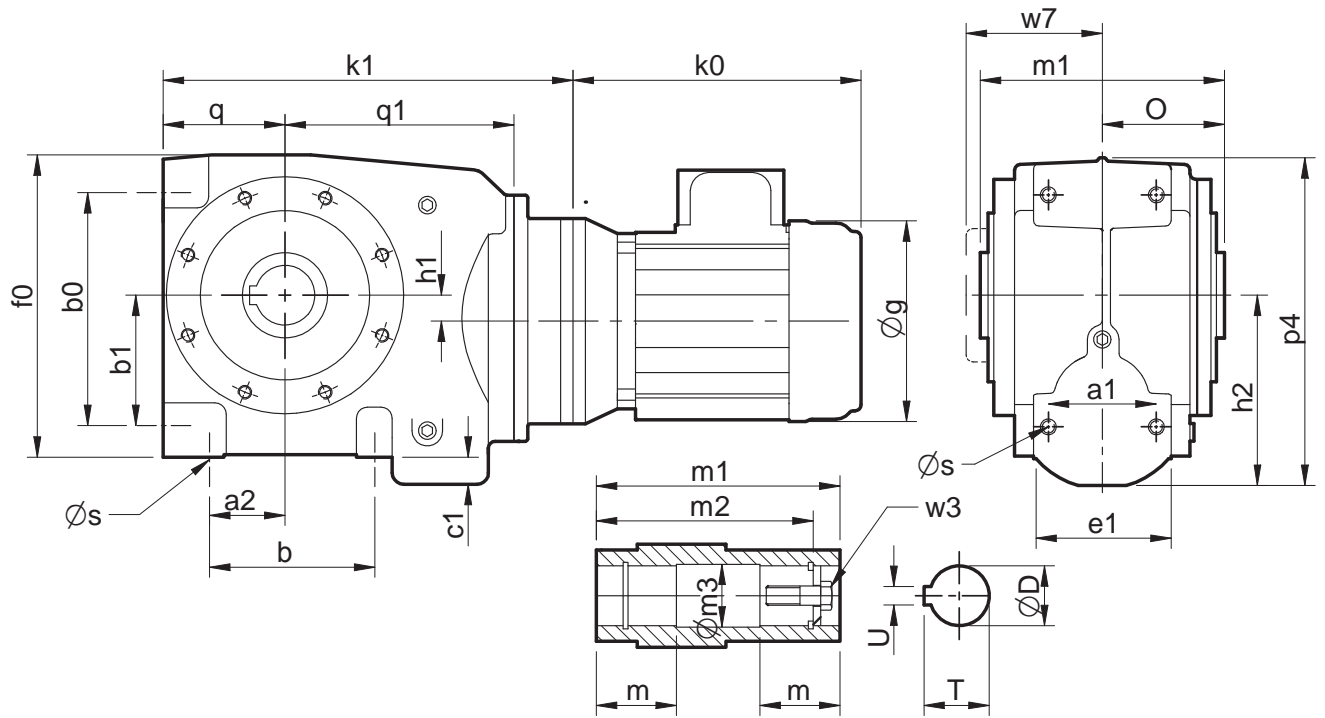

Size	a1	a2	b	b0	b1	c1	e1	f0	h1	h2	o	p4	q	q1
C0321	54	35	63	80	40	9	70	139	5.3	79.5	62	148	54	109
C0421	56	35	80	118	65	7	80	158	15	93	65	168	64	119
C0521	68	45	100	142	77	16	86	177	13	112	70	200	68	134
C0621	80	56	122	172	96	20	102	218	17	139.5	90	243	90	169

Size	s	w7	D	m	m1	m2	m3	T	U	w3
C0321	M8 x 1.25 x 15	70	20	52	124	104	20.2	22.9	6	M6 x 1.0 x 40
C0421	M10 x 1.5 x 20	74.5	30	54	130	122	30.2	33.5	8	M10 x 1.5 x 50
C0521	M10 x 1.5 x 18	79	35	56	140	127	35.3	38.5	10	M12 x 1.75 x 55
C0621	M12 x 1.75 x 20	101	45	70	180	156	45.3	49	14	M16 x 2.0 x 70

Size			C0321	C0421	C0521	C0621
	k0	g	k1	k1	k1	k1
63	195	125	197	217	236	271
71	220	140	201	221	240	277
80	240	160	214	234	253	295
90S	260	180	224	244	263	305
90L	280	180	224	244	263	305
100L	310	200	232	252	271	332
112M	330	225	232	252	271	332

SERIES C

DIMENSIONS

DOUBLE REDUCTION

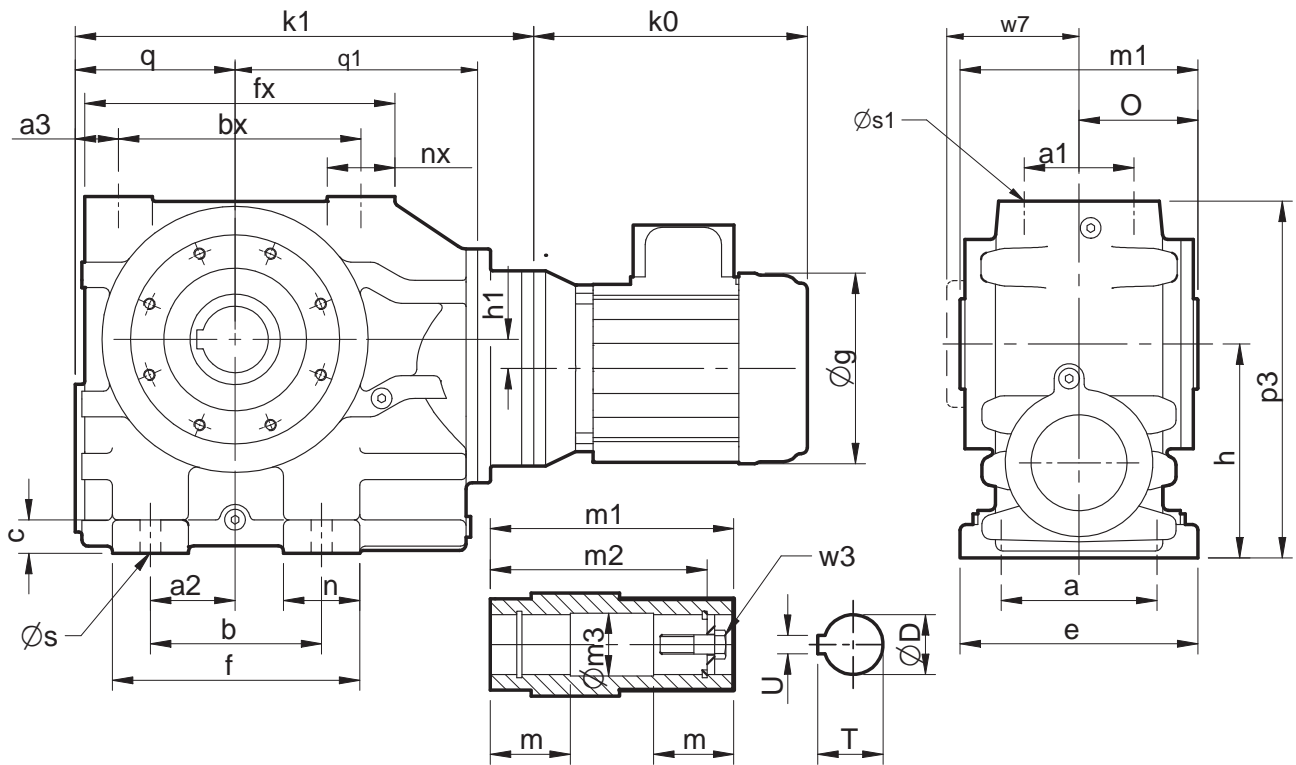

Size	a	a1	a2	a3	b	bx	c	e	f	fx	h	h1	n	nx	o	p3	q	q1
C0721	150	100	75	35.5	135	215	28	185	202	280	180	26	67	63	109	302	143	220
C0821	200	120	92	43	180	250	35	250	260	326	225	28	80	71	125	375	168	255
C0921	250	135	115	50	235	290	40	305	320	380	280	40	85	85	150	457	195	300

Size	s	s1	w7	D	m	m1	m2	m3	T	U	w3
C0721	18	M20 x 2.5 x 34	125	60	79	218	188	60.5	64.6	18	M20 x 2.5, 80
C0821	22	M20 x 2.5 x 34	143	70	90	250	220	70.5	75.1	20	M20 x 2.5, 80
C0921	26	M24 x 3.0 x 45	169	90	107.5	300	265	90.5	95.6	25	M24 x 3.0 x 110
C1021	26	M24 x 3.0 x 45	198	100	132.5	350	313	100.5	106.6	28	M24 x 3.0 x 110

Size	C0721		C0821	C0921	C1021
	k0	g	k1	k1	k1
80	240	160	400	505	553
90S	260	180	410	505	553
90L	280	180	410	505	553
100L	310	200	422	511	559
112M	330	225	422	511	559
132S	380	260	444	511	559
132M	420	260	444	511	559
160M	480	320	452	541	594
160L	530	320	452	541	594
180M	560	360	-	-	594
180L	595	360	-	-	594
200L	660	400	-	-	594
225S	680	450	-	-	621
225M	725	450	-	-	621

SERIES C

DIMENSIONS

QUADRUPLE REDUCTION

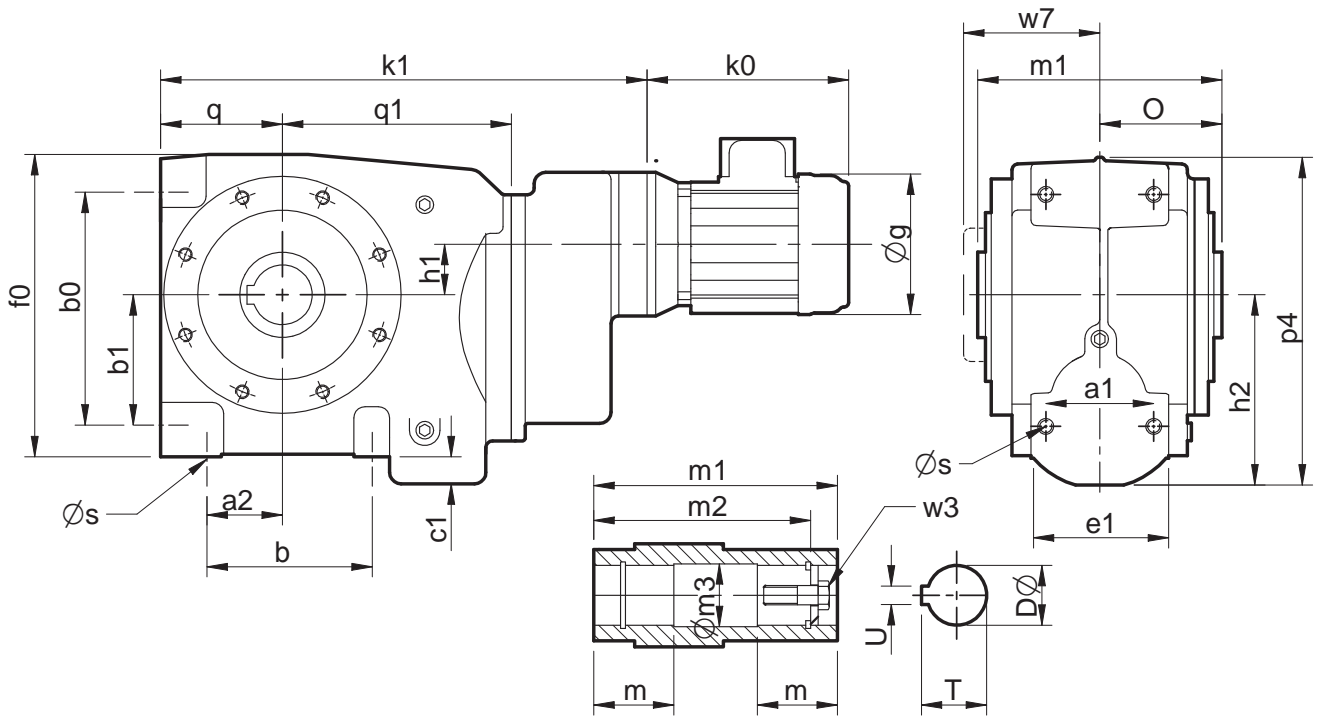

Size	a1	a2	b	b0	b1	c1	e1	f0	h1	h2	o	p4	q	q1
C0331	54	35	63	80	40	9	70	139	30.75	79.5	62	148	54	109
C0431	56	35	80	118	65	7	80	158	21.2	93	65	168	64	119
C0531	68	46	100	142	77	16	86	177	23	112	70	200	68	134
C0631	80	56	122	172	96	20	102	218	30	139.5	90	243	90	169

Size	s	w7	D	m	m1	m2	m3	T	U	w3
C0331	M8 x 1.25 x 15	70	20	52	124	104	20.2	22.9	6	M6 x 1.0 x 40
C0431	M10 x 1.5 x 18	74.5	30	54	130	122	30.2	33.5	8	M10 x 1.5 x 50
C0531	M10 x 1.5 x 18	79	35	56	140	127	35.3	38.5	10	M12 x 1.75 x 55
C0631	M12 x 1.75 x 20	101	45	70	180	156	45.3	49	14	M16 x 2.0 x 70

Size			C0331	C0431	C0531	C0631
	k0	g	k1	k1	k1	k1
63	195	125	253	273	292	359
71	220	140	257	277	296	363
80	240	160	270	290	309	376
90S	260	180	280	300	319	386
90L	280	180	280	300	319	386
100L	310	200	288	308	327	394
112M	330	225	288	308	327	394

SERIES C

DIMENSIONS

QUADRUPLE REDUCTION

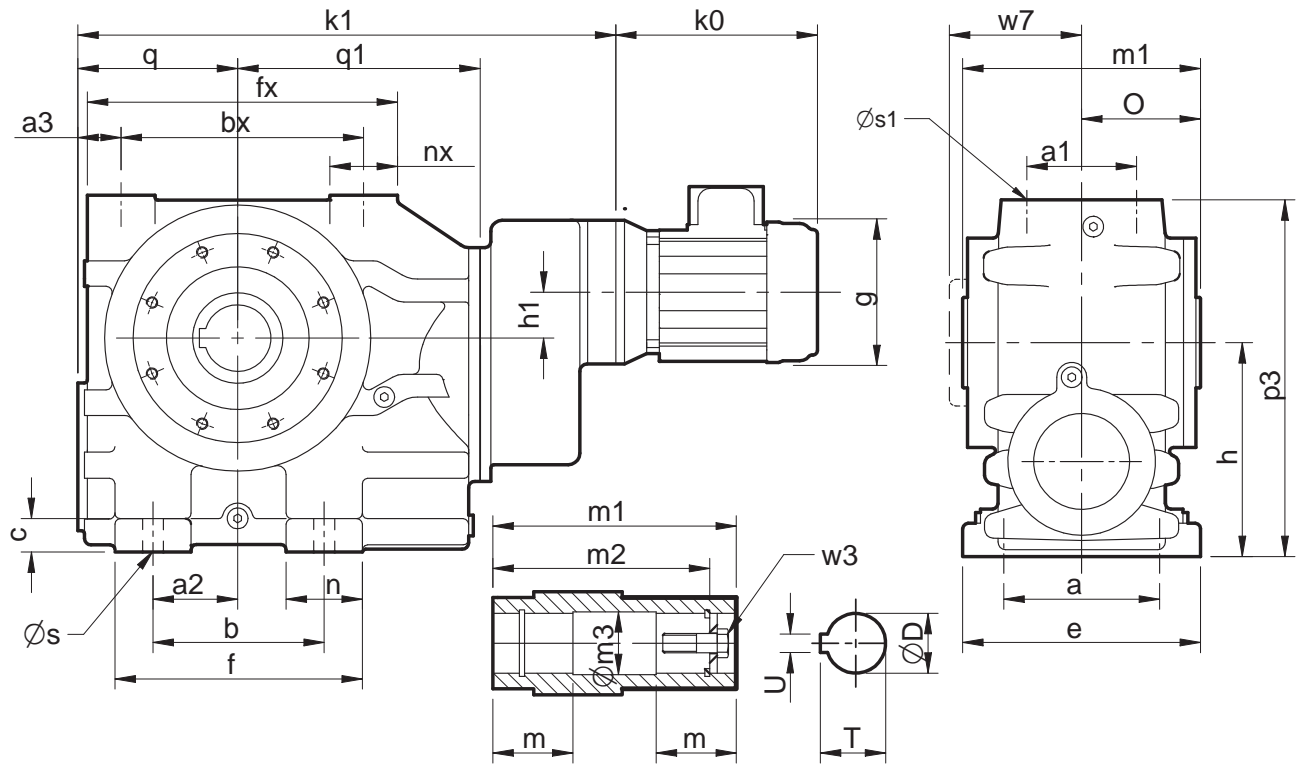

Size	a	a1	a2	a3	b	bx	c	e	f	fx	h	h1	n	nx	o	p3	q	q1
C0731	150	100	75	35.5	135	215	28	185	202	280	180	34	67	63	109	302	143	220

Size	s	s1	w7	D	m	m1	m2	m3	T	U	w3
C0731	18	M20 x 2.5 x 34	125	60	79	218	188	60.5	64.6	18	M20 x 2.5 x 80

Size	C0721		
	k0	g	k1
63	195	125	461
71	220	140	467
80	240	160	485
90S	260	180	495
90L	280	180	495
100L	310	200	522
112M	330	225	522
132S	380	260	522
132M	420	260	522

SERIES C

DIMENSIONS

QUADRUPLE REDUCTION

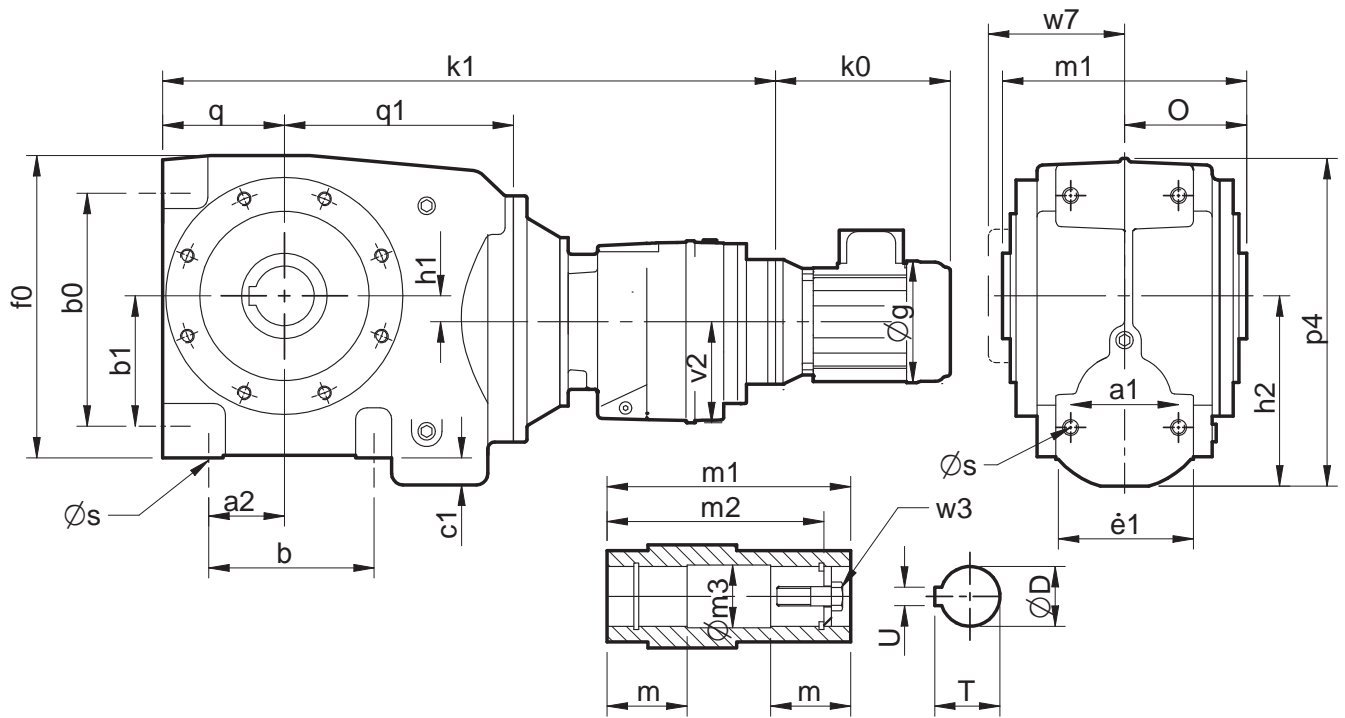

Size	a1	a2	b	b0	b1	c1	e1	f0	h1	h2	o	p4	q	q1
C0341	54	35	63	80	40	9	70	139	5.3	79.5	62	148	54	109
C0441	56	35	80	118	65	7	80	158	15	93	65	168	64	119
C0541	68	45	100	142	77	16	86	177	13	112	70	200	68	134
C0641	80	56	122	172	96	20	102	218	17	139.5	90	243	90	169

Size	s	v2	w7	D	m	m1	m2	m3	T	U	w3
C0341	M8 x 1.25 x 15	76	70	20	52	124	104	20.2	22.9	6	M6 x 1.0 x 40
C0441	M10 x 1.5 x 20	76	74.5	30	54	130	122	30.2	33.5	8	M10 x 1.5 x 50
C0541	M10 x 1.5 x 18	76	79	35	56	140	127	35.3	38.5	10	M12 x 1.75 x 55
C0641	M12 x 1.75 x 20	91	101	45	70	180	156	45.3	49	14	M16 x 2.0 x 70

Size	C0341						C0441						C0541						C0641					
	k0	g	k1	k1	k1	k1	k0	g	k1	k1	k1	k1	k0	g	k1	k1	k1	k1	k0	g	k1	k1	k1	k1
63	195	125	383	403	422	495	195	125	383	403	422	495	195	125	383	403	422	495	195	125	383	403	422	495
71	220	140	387	407	426	499	220	140	387	407	426	499	220	140	387	407	426	499	220	140	387	407	426	499
80	240	160	400	420	439	512	240	160	400	420	439	512	240	160	400	420	439	512	240	160	400	420	439	512
90S	260	180	410	430	449	522	260	180	410	430	449	522	260	180	410	430	449	522	260	180	410	430	449	522
90L	280	180	410	430	449	522	280	180	410	430	449	522	280	180	410	430	449	522	280	180	410	430	449	522
100L	310	200	418	438	457	530	310	200	418	438	457	530	310	200	418	438	457	530	310	200	418	438	457	530
112M	330	225	418	438	457	530	330	225	418	438	457	530	330	225	418	438	457	530	330	225	418	438	457	530

SERIES C

DIMENSIONS

QUADRUPLE REDUCTION

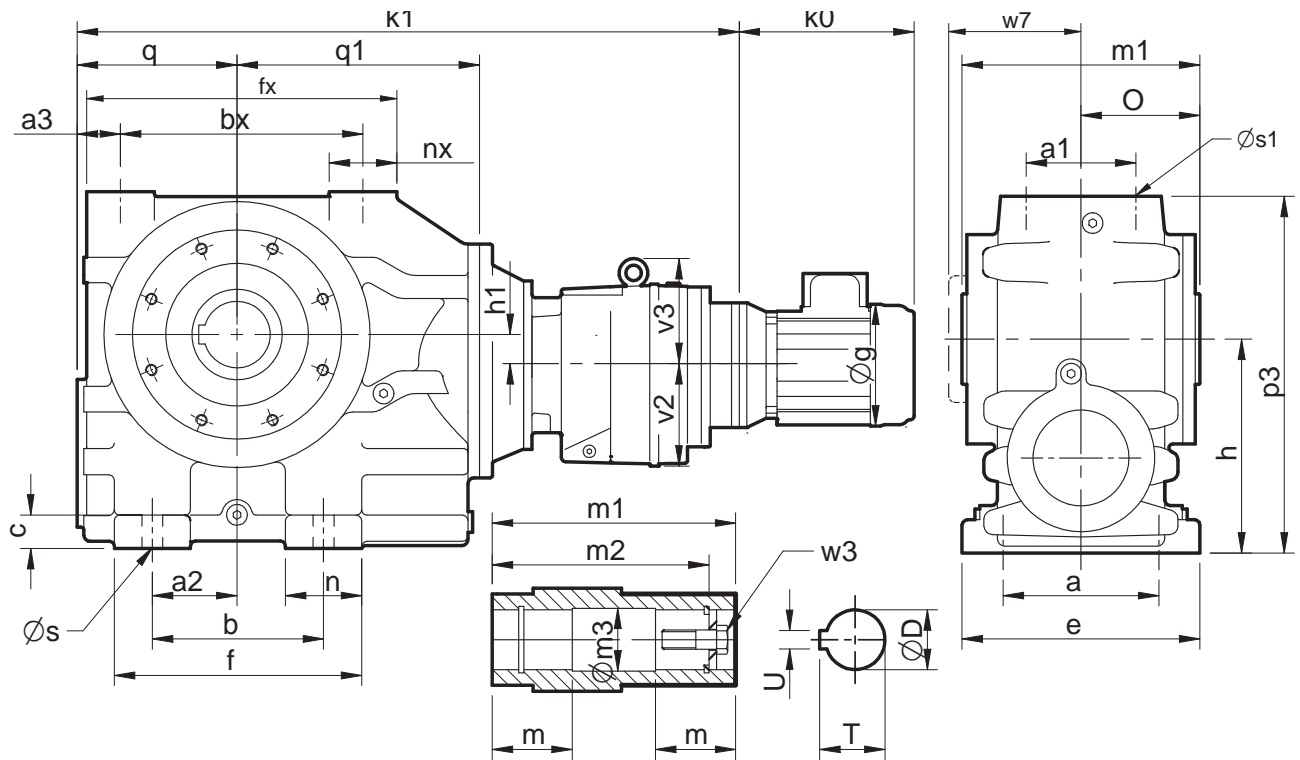

Size	a	a1	a2	a3	b	bx	c	e	f	fx	h	h1	n	nx	o	p3	q	q1
C0741	150	100	75	35.5	135	215	28	185	202	280	180	26	67	63	109	302	143	220
C0841	200	120	92	43	180	250	35	250	260	326	225	28	80	71	125	375	168	255
C0941	250	135	115	50	235	290	40	305	320	380	280	40	85	85	150	457	195	300
C1041	300	150	170	62.5	310	345	45	360	420	460	335	65	110	107	175	565	235	355

Size	s	s1	v2	v3	w7	D	m	m1	m2	m3	T	U	w3
C0741	18	M20 x 2.5 x 34	91	-	125	60	79	218	188	60.5	64.6	18	M20 x 2.5 x 80
C0841	22	M20 x 2.5 x 34	115	-	143	70	90	250	220	70.5	75.1	20	M20 x 2.5 x 80
C0941	26	M24 x 3.0 x 45	115	-	169	90	107.5	300	265	90.5	95.6	25	M24 x 3.0 x 110
C1041	26	M24 x 3.0 x 45	140	155	198	100	132.5	350	313	100.5	106.6	28	M24 x 3.0 x 110

Size			C0741	C0841	C0941	C1041
	k0	g	k1	k1	k1	k1
63	195	125	600	680	763	-
71	220	140	604	686	769	-
80	240	160	617	704	787	919
90S	260	180	627	714	797	929
90L	280	180	627	714	797	929
100L	310	200	635	741	824	941
112M	330	225	635	741	824	941
132S	380	260	-	741	824	963
132M	420	260	-	741	824	963
160M	480	320	-	-	-	971
160L	530	320	-	-	-	971

SERIES C

DIMENSIONS

UNITS WITH COMPACT MOTOR

Double Reduction Units

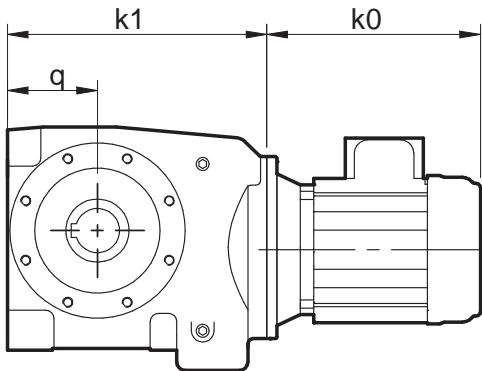

C0321 - C0621

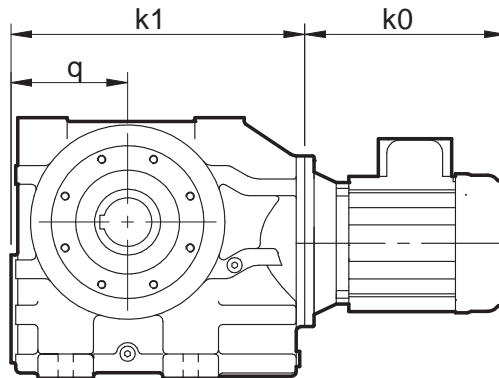

C0721 - C0821

Size	C0321				C0421			C0521			C0621			C0721			C0821			
	g	k1	k0	q	k1	k0	q	k1	k0	q	k1	k0	q	k1	k0	q	k1	k0	q	
0.25 kW	140	163	230	54	183	230	64	202	230	68	-	-	-	-	-	-	-	-	-	-
0.37 kW	140	163	230	54	183	230	64	202	230	68	-	-	-	-	-	-	-	-	-	-
0.55 kW	158	163	280	54	183	280	64	202	280	68	259	265	90	-	-	-	-	-	-	-
0.75 kW	158	163	300	54	183	300	64	202	300	68	259	285	90	-	-	-	-	-	-	-
1.1 kW	180	163	330	54	183	330	64	202	330	68	259	315	90	363	300	143	-	-	-	-
1.5 kW	180	163	365	54	183	365	64	202	365	68	259	350	90	363	335	143	-	-	-	-
2.2 kW	198	-	-	-	-	-	-	-	-	-	259	355	90	363	340	143	423	335	168	-
3.0 kW	198	-	-	-	-	-	-	-	-	-	259	365	90	363	350	143	423	350	168	-
4.0 kW	222	-	-	-	-	-	-	-	-	-	259	424	90	363	410	143	423	400	168	-
5.5 kW	262	-	-	-	-	-	-	-	-	-	259	495	90	363	480	143	423	475	168	-
7.5 kW	262	-	-	-	-	-	-	-	-	-	-	-	-	363	480	143	423	475	168	-

Triple Reduction Units

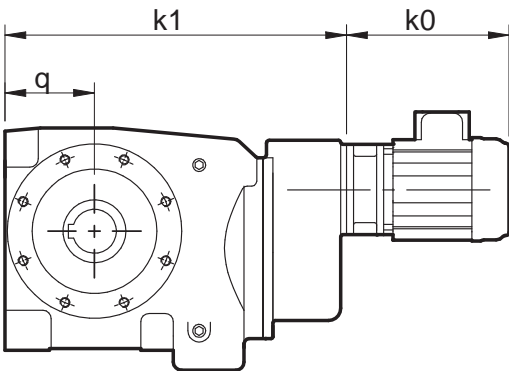

C0331 - C0631

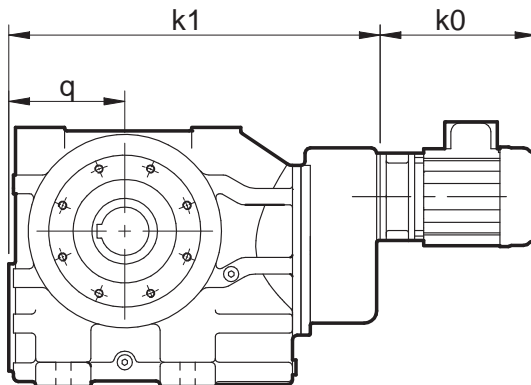

C0731 - C0831

Size	C0331				C0431			C0531			C0631			C0731		
	g	k1	k0	q	k1	k0	q	k1	k0	q	k1	k0	q	k1	k0	q
0.25 kW	140	219	230	54	239	230	64	258	230	68	325	230	90	-	-	-
0.37 kW	140	219	230	54	239	230	64	258	230	68	325	230	90	-	-	-
0.55 kW	160	219	280	54	239	280	64	258	280	68	325	280	90	449	265	143
0.75 kW	160	219	300	54	239	300	64	258	300	68	325	300	90	449	285	143
1.1 kW	180	210	330	54	239	330	64	258	330	68	325	330	90	449	315	143
1.5 kW	180	219	365	54	239	365	64	258	365	68	325	365	90	449	350	143
2.2 kW	200	-	-	-	-	-	-	-	-	-	-	-	-	449	355	143
3.0 kW	200	-	-	-	-	-	-	-	-	-	-	-	-	449	365	143
4.0 kW	225	-	-	-	-	-	-	-	-	-	-	-	-	449	424	143
5.5 kW	260	-	-	-	-	-	-	-	-	-	-	-	-	449	495	143

SERIES C

DIMENSIONS

UNITS WITH COMPACT MOTOR

Quadruple Reduction Units

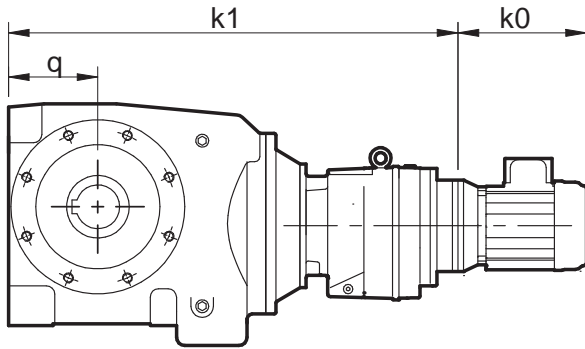

C0341 - C0641

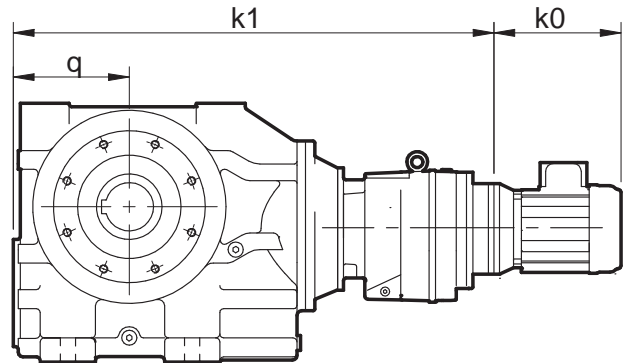

C0741 - C0841

Size	C0341				C0441			C0541			C0641			C0741		
	g	k1	k0	q	k1	k0	q	k1	k0	q	k1	k0	q	k1	k0	q
0.25 kW	140	349	230	54	369	230	64	388	230	68	461	230	90	566	230	143
0.37 kW	140	349	230	54	369	230	64	388	230	68	461	230	90	566	230	143
0.55 kW	160	349	280	54	369	280	64	388	280	68	461	280	90	566	280	143
0.75 kW	160	349	300	54	369	300	64	388	300	68	461	300	90	566	300	143

Size	C0841				C0941			C1041		
	g	k1	k0	q	k1	k0	q	k1	k0	q
0.55 kW	160	668	265	168	751	265	195	-	-	-
0.75 kW	160	668	285	168	751	285	195	-	-	-
1.1 kW	180	668	315	168	751	315	195	882	300	235
1.5 kW	180	668	350	168	751	350	195	882	335	235
2.2 kW	200	668	355	168	751	355	195	882	340	235
3.0 kW	200	668	365	168	751	365	195	882	350	235
4.0 kW	225	668	424	168	751	424	195	882	410	235
5.5 kW	260	668	495	168	751	495	195	882	480	235
7.5 kW	-	-	-	-	-	-	-	882	480	235

SERIES C

GEAR UNIT OPTIONS

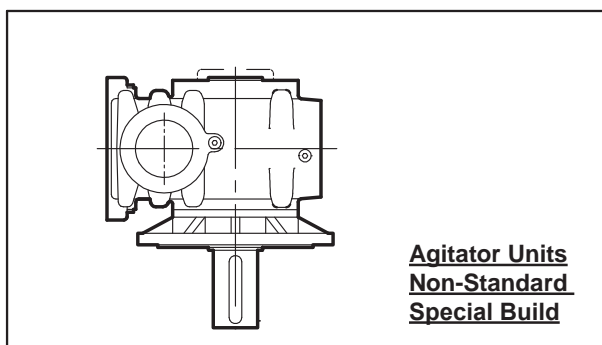
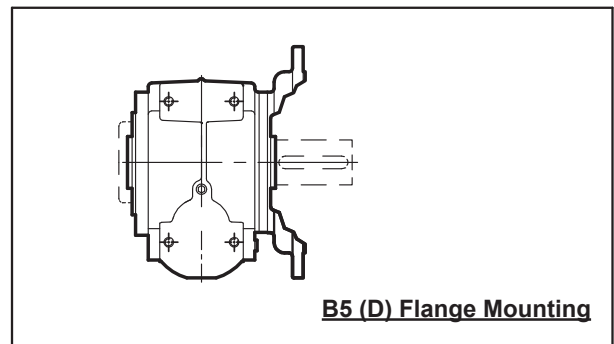
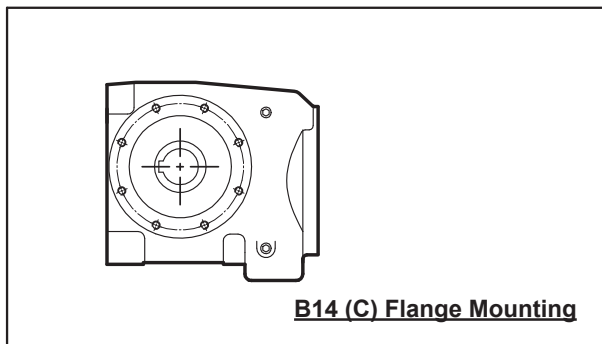
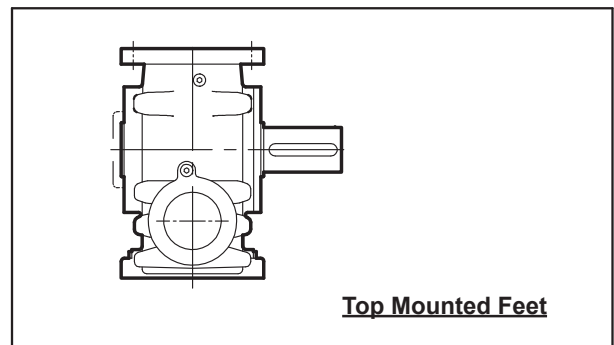
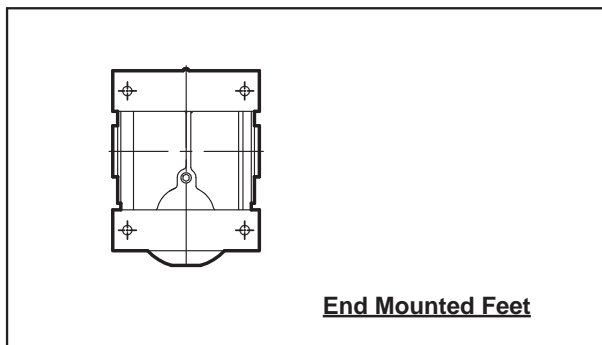
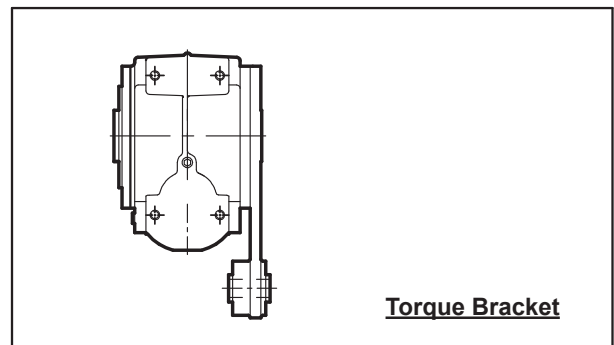
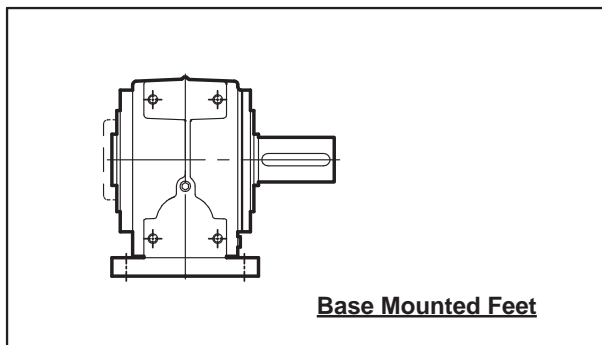
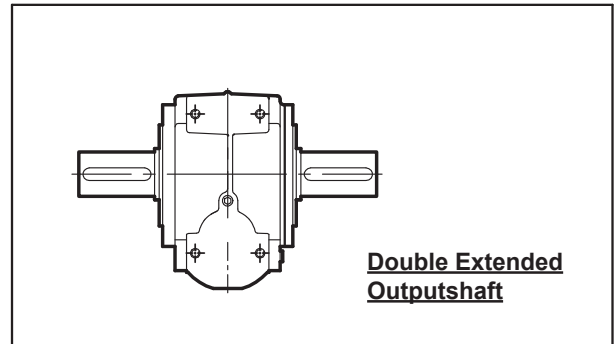
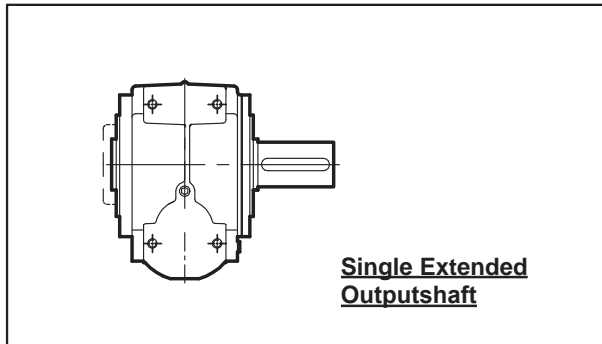

SERIES C

MOTORISED BACKSTOP MODULE

Motorised backstop modules can be fitted between the gear unit and motor. The backstop device incorporates high quality centrifugal lift off sprags which are wear free above the lift off speed (n min). To ensure correct operation motor speed must exceed lift off speed.

Suitable for ambient temperature -40°C to + 50°C

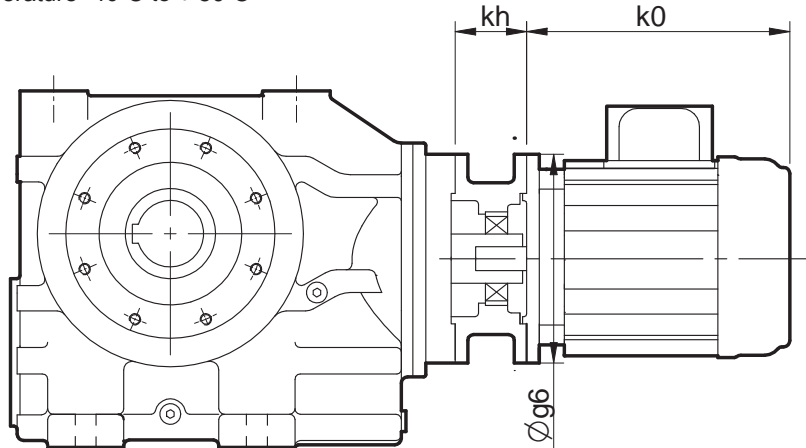

Warning

Removal of motor or backstop will release the drive. Ensure all driven machinery is secure prior to any maintenance work

IEC B5 FLANGE

Motor Frame Size	Lift off Speed ('n' min) (rev/min)	Rated Locking Torque ('T max') (at motor) (Nm)	øg6	kh
100	670	170	250	70
112	670	170	250	70
132	620	940	300	95
160	620	940	350	130
180	620	940	350	130
200	550	1260	400	130

NEMA C FLANGE

Motor Frame Size	Lift off Speed ('n' min) (rev/min)	Rated Locking Torque ('T max') (at motor) (Nm)	øg6	kh
182TC / 184TC	670	300	228	95.25
213TC / 215TC	670	300	228	95.25
254TC / 256TC	620	940	228	120.65
284TC / 286TC	620	940	280	136.50
324TC / 326TC	550	1260	330	152.40

When a backstop module is fitted dimension kh should be added to the overall length of the geared motor assembly.

Rotation of outputshaft must be specified when ordering as viewed from the outputshaft end (as shown in the diagram)

- | | | | | |
|--------|-------|-------------------|-------|-------------------|
| CW | - | Free Rotation | - | Clockwise |
| | | Locked | | Anticlockwise |
|
AC |
- |
Free Rotation |
- |
Anticlockwise |
| | | Locked | | Clockwise |

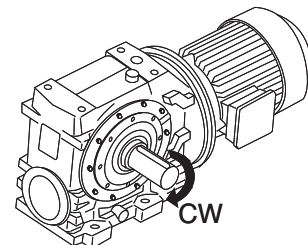

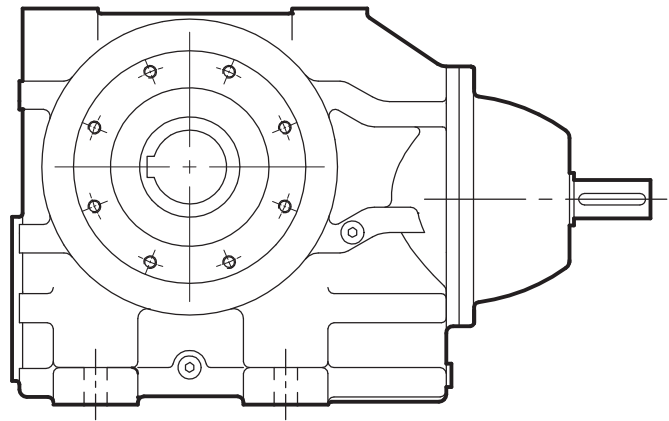
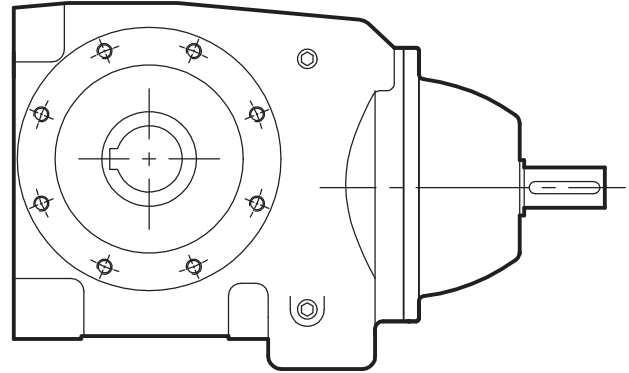

REDUCER

SERIES C

SERIES C

OVERHUNG & AXIAL LOADS (NEWTONS) ON SHAFTS

Maximum permissible overhung loads

When a sprocket, gear etc. is mounted on the shaft a calculation, as below, must be made to determine the overhung load on the shaft, and the results compared to the maximum permissible overhung loads tabulated. Overhung loads can be reduced by increasing the diameter of the sprocket, gear, etc. If the maximum permissible overhung load is exceeded, the sprocket, gear, etc. should be mounted on a separate shaft, flexibly coupled and supported in its own bearings, or the gear unit shaft should be extended to run in an outboard bearing. Alternatively, a larger gear is often a less expensive solution.

Permissible overhung loads vary according to the direction of rotation. The values tabulated are for the most unfavourable direction with the unit transmitting full rated power and the load P applied midway along the shaft extension. Hence they can sometimes be increased for a more favourable direction of rotation, or if the power transmitted is less than the rated capacity of the gear unit, or if the load is applied nearer to the gear unit case. Refer to our Application Engineers for further details. In any event, the sprocket, gear etc. should be positioned as close as possible to the gear unit case in order to reduce bearing loads and shaft stresses, and to prolong life. All units will accept 100% momentary overload on stated capacities.

Overhung load (Newtons)

$$P = \frac{kW \times 9,500,000 \times K}{N \times R}$$

where

- P = equivalent overhung load (Newtons)
 kW = power transmitted by the shaft (kilowatts)
 N = speed of shaft (rpm)
 R = pitch radius of sprocket, etc. (mm)
 K = factor

1 Newton = 0.10197kG (0.2248 lbs)

Overhung load

K (factor)

Chain sprocket*	1.00
Spur or helical pinion	1.25
Vee belt sheave	1.50
Flat belt pulley	2.00

* If multistrand chain drives are equally loaded and the outer strand is further than dimension A output or B input, refer to our Application Engineers.

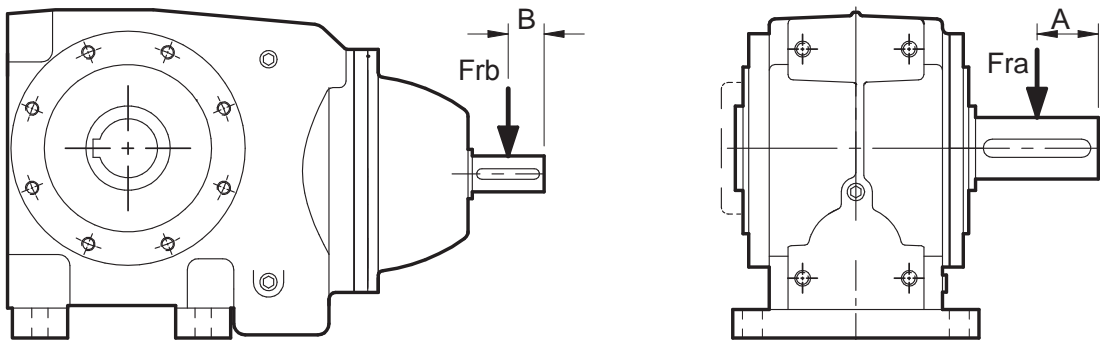

Distance midway along the shaft extension

Size of unit	No. of Reductions	Dimension A (mm)	Dimension B (mm)
C03	2 - 3	17.5	20
C04	2 - 3	23	20
C05	2 - 3	30	20
C06	2 - 5	31.5	20
C07	2	38	25
C07	3 - 5	38	20
C08	2	60	30
C08	4 - 5	60	20
C09	2	67.5	40
C09	4 - 5	67.5	20
C10	2	85	55
C10	4	85	25
C10	5	85	20

Inputshaft Overhung Loads, Frb (Kn) 1450 rpm - Two Three and Four Stage Units

	C03	C04	C05	C06	C07	C08	C09	C10
2 Stage	1.50	1.50	1.25	1.05	2.1	3.1	3.5	4.5
4 Stage	1.50	1.50	1.50	1.50	1.50	1.50	1.50	1.80

For output overhung load Fra consult ratings tables.

Axial Thrust Capacities (Newtons) No check or calculation is required for axial loads (FA) towards or away from the unit up to 50% of the permissible overhung load. If the axial thrust considerably exceeds these values or if there is a combination of axial thrust loads and overhung loads please contact our Application Engineers.

SERIES C

RATINGS

Key: Pm= Input Power (kW) M2= Output Torque (Nm) i= Exact Ratio n2= Output Speed (rpm) Fra = Overhung load (kN)

			n1 = 1450					n1 = 960					n1 = 2900					n1 = 725				
	<i>n</i>	<i>i</i>	n2	M2	η (%)	Pm	Fra	n2	M2	η (%)	Pm	Fra	n2	M2	η (%)	Pm	Fra	n2	M2	η (%)	Pm	Fra
C0321	8.0	8.591	169	80	83	1.70	2.78	112	88	83	1.24	2.78	338	66	84	2.78	2.78	84	95	82	1.02	2.78
	11.	11.61	125	87	83	1.37	2.78	83	96	81	1.03	2.78	250	74	84	2.30	2.78	62	102	80	0.83	2.78
	12.	13.20	110	90	82	1.26	2.78	73	99	81	0.93	2.78	220	77	84	2.11	2.78	55	105	80	0.75	2.78
	14.	14.95	97	93	82	1.15	2.78	64	102	80	0.86	2.78	194	79	83	1.93	2.78	48	109	80	0.69	2.78
	16.	16.36	89	87	73	1.11	2.78	59	96	71	0.83	2.78	177	69	74	1.73	2.78	44	103	70	0.68	2.78
	18.	19.12	76	99	81	0.97	2.78	50	108	80	0.71	2.78	152	84	83	1.61	2.78	38	115	79	0.58	2.78
	20.	20.61	70	101	81	0.92	2.78	47	110	79	0.68	2.78	141	86	83	1.53	2.78	35	117	79	0.55	2.78
	22.	22.11	66	94	72	0.90	2.78	43	104	70	0.68	2.78	131	79	74	1.47	2.78	33	111	69	0.55	2.78
	25.	25.14	58	97	71	0.83	2.78	38	107	69	0.62	2.78	115	82	73	1.36	2.78	29	114	68	0.51	2.78
	28.	28.48	51	85	70	0.65	2.78	34	111	69	0.57	2.78	102	85	73	1.24	2.78	25	118	68	0.46	2.78
	32.	33.71	43	113	79	0.64	2.78	28	125	78	0.48	2.78	86	98	81	1.09	2.78	22	137	78	0.40	2.78
	36.	36.43	40	107	69	0.65	2.78	26	117	68	0.47	2.78	80	91	72	1.05	2.78	20	125	67	0.39	2.78
	40.	39.26	37	110	68	0.63	2.78	24	120	68	0.45	2.78	74	93	72	1.00	2.78	18	127	66	0.37	2.78
	45.	45.50	32	122	79	0.52	2.78	21	122	77	0.35	2.78	64	105	80	0.88	2.78	16	149	76	0.33	2.78
	50.	53.31	27	127	78	0.46	2.78	18	145	77	0.36	2.78	54	109	80	0.78	2.78	14	149	76	0.28	2.78
	56.	56.19	26	120	68	0.48	2.78	17	131	66	0.36	2.78	52	104	70	0.80	2.78	13	141	65	0.29	2.78
	63.	64.21	23	124	67	0.44	2.78	15	135	65	0.33	2.78	45	107	70	0.72	2.78	11	147	64	0.27	2.78
	71.	74.55	19	143	76	0.38	2.78	13	149	76	0.26	2.78	39	124	78	0.65	2.78	9.7	149	75	0.20	2.78
	80.	82.83	18	147	76	0.35	2.78	12	150	75	0.24	2.78	35	127	78	0.60	2.78	8.8	150	75	0.18	2.78
	90.	86.67	17	139	66	0.37	2.78	11	150	64	0.27	2.78	33	121	69	0.61	2.78	8.4	150	63	0.21	2.78
	100	101.5	14	143	65	0.33	2.78	9.5	150	63	0.24	2.78	29	124	68	0.55	2.78	7.1	150	63	0.18	2.78
	112	114.3	13	129	75	0.23	2.78	8.4	150	75	0.18	2.78	25	132	77	0.46	2.78	6.3	150	74	0.13	2.78
	125	129.0	11	127	75	0.20	2.78	7.4	150	74	0.16	2.78	22	130	77	0.40	2.78	5.6	150	73	0.12	2.78
	140	142.0	10	149	63	0.25	2.78	6.8	150	62	0.17	2.78	20	133	66	0.43	2.78	5.1	150	61	0.13	2.78
	160	157.8	9.2	150	63	0.23	2.78	6.1	150	62	0.15	2.78	18	136	66	0.40	2.78	4.6	150	61	0.12	2.78
212	217.8	6.7	150	62	0.17	2.78	4.4	150	61	0.11	2.78	13	146	65	0.31	2.78	3.3	150	60	0.09	2.78	
250	247.5	5.9	150	61	0.15	2.78	3.9	150	60	0.10	2.78	12	149	64	0.29	2.78	2.9	150	59	0.08	2.78	
C0331	100	105.4	14	150	74	0.29	2.78	9.1	150	74	0.19	2.78	28	126	75	0.48	2.78	6.9	150	73	0.15	2.78
	118	120.4	12	150	74	0.26	2.78	8.0	150	74	0.17	2.78	24	132	75	0.44	2.78	6.0	150	73	0.13	2.78
	132	130.1	11	150	63	0.28	2.78	7.4	150	61	0.19	2.78	22	120	64	0.44	2.78	5.6	150	60	0.15	2.78
	150	140.2	10	150	63	0.26	2.78	6.8	150	61	0.18	2.78	21	122	64	0.41	2.78	5.2	150	60	0.14	2.78
	160	162.5	8.9	150	73	0.19	2.78	5.9	150	73	0.13	2.78	18	146	75	0.36	2.78	4.5	150	72	0.10	2.78
	180	190.4	7.6	150	73	0.16	2.78	5.0	150	73	0.11	2.78	15	149	75	0.32	2.78	3.8	150	72	0.083	2.78
	200	200.7	7.2	150	61	0.19	2.78	4.8	150	60	0.13	2.78	14	136	63	0.33	2.78	3.6	150	59	0.096	2.78
	225	229.3	6.3	150	61	0.16	2.78	4.2	150	59	0.11	2.78	13	142	62	0.30	2.78	3.2	150	59	0.084	2.78
	265	266.2	5.4	150	72	0.12	2.78	3.6	150	71	0.080	2.78	11	149	73	0.23	2.78	2.7	150	71	0.060	2.78
	280	295.8	4.9	150	71	0.11	2.78	3.2	150	71	0.072	2.78	9.8	150	73	0.21	2.78	2.5	150	71	0.054	2.78
	315	309.5	4.7	150	59	0.12	2.78	3.1	150	58	0.084	2.78	9.4	150	61	0.24	2.78	2.3	150	58	0.063	2.78
	360	362.6	4.0	150	59	0.11	2.78	2.6	150	58	0.072	2.78	8.0	150	61	0.21	2.78	2.0	150	58	0.054	2.78
	400	408.3	3.6	150	71	0.079	2.78	2.4	150	71	0.052	2.78	7.1	150	72	0.15	2.78	1.8	150	71	0.039	2.78
	450	464.1	3.1	150	71	0.069	2.78	2.1	150	70	0.046	2.78	6.2	150	72	0.14	2.78	1.6	150	70	0.035	2.78
	500	507.1	2.9	150	58	0.077	2.78	1.9	150	57	0.052	2.78	5.7	150	59	0.15	2.78	1.4	150	57	0.039	2.78
	560	563.5	2.6	150	57	0.071	2.78	1.7	150	57	0.047	2.78	5.1	150	59	0.14	2.78	1.3	150	57	0.035	2.78
800	777.8	1.9	150	57	0.051	2.78	1.2	150	57	0.034	2.78	3.7	150	59	0.10	2.78	0.93	150	57	0.026	2.78	
900	883.9	1.6	150	57	0.045	2.78	1.1	150	57	0.030	2.78	3.3	150	58	0.089	2.78	0.82	150	56	0.023	2.78	
C0341	10C	960	1.5	150	70	0.034	2.78	1.0	150	70	0.022	2.78	3.0	150	70	0.068	2.78	0.76	150	70	0.017	2.78
	11C	1097	1.3	150	70	0.030	2.78	0.88	150	70	0.020	2.78	2.6	150	70	0.059	2.78	0.66	150	70	0.015	2.78
	12C	1220	1.2	150	70	0.027	2.78	0.79	150	70	0.018	2.78	2.4	150	70	0.053	2.78	0.59	150	70	0.013	2.78
	14C	1345	1.1	150	70	0.024	2.78	0.71	150	70	0.016	2.78	2.2	150	70	0.048	2.78	0.54	150	70	0.012	2.78
	16C	1635	0.89	150	69	0.020	2.78	0.59	150	69	0.013	2.78	1.8	150	69	0.040	2.78	0.44	150	69	0.010	2.78
	18C	1735	0.84	150	70	0.019	2.78	0.55	150	70	0.012	2.78	1.7	150	70	0.038	2.78	0.42	150	70	0.009	2.78
	20C	1916	0.76	150	69	0.017	2.78	0.50	150	69	0.011	2.78	1.5	150	69	0.034	2.78	0.38	150	69	0.009	2.78
	22C	2081	0.70	150	70	0.016	2.78	0.46	150	70	0.010	2.78	1.4	150	70	0.031	2.78	0.35	150	70	0.008	2.78
	25C	2426	0.60	150	70	0.013	2.78	0.40	150	70	0.009	2.78	1.2	150	70	0.027	2.78	0.30	150	70	0.007	2.78
	28C	2679	0.54	150	69	0.012	2.78	0.36	150	69	0.008	2.78	1.1	150	69	0.025	2.78	0.27	150	69	0.006	2.78
	32C	3246	0.45	150	70	0.010	2.78	0.30	150	70	0.007	2.78	0.89	150	70	0.020	2.78	0.22	150	70	0.005	2.78
	36C	3585	0.40	150	69	0.009	2.78	0.27	150	69	0.006	2.78	0.81	150	69	0.018	2.78	0.20	150	69	0.005	2.78
	40C	4109	0.35	150	69	0.008	2.78	0.23	150	69	0.005	2.78	0.71	150	69	0.016	2.78	0.18	150	69	0.004	2.78
	45C	4670	0.31	150	69	0.007	2.78	0.21	150	69	0.005	2.78	0.62	150	69	0.014	2.78	0.16	150	69	0.004	2.78
	50C	4978	0.29	150	68	0.007	2.78	0.19	150	68	0.004	2.78	0.58	150	68	0.013	2.78	0.15	150	68	0.003	2.78
	56C	5658	0.26	150	68	0.006	2.78	0.17	150	68	0.004	2.78	0.51	150	68	0.012	2.78	0.13	150	68	0.003	2.78
	63C	6485	0.22	150	68	0.005	2.78	0.15	150	68	0.003	2.78	0.45	150	68	0.010	2.78	0.11	150	68	0.003	2.78
	71C	7370	0.20	150	68	0.005	2.78	0.13	150	68	0.003	2.78	0.39	150	68	0.009	2.78	0.10	150	68	0.002	2.78
80C	7874	0.18	150	53	0.005	2.78	0															

SERIES C

RATINGS

Key: Pm= Input Power (kW) M2= Output Torque (Nm) i= Exact Ratio n2= Output Speed (rpm) Fra = Overhung load (kN)

			n1 = 1450					n1 = 960					n1 = 2900					n1 = 725				
	<i>n</i>	<i>i</i>	n2	M2	η (%)	Pm	Fra	n2	M2	η (%)	Pm	Fra	n2	M2	η (%)	Pm	Fra	n2	M2	η (%)	Pm	Fra
C0421	8.0	8.591	169	137	85	2.85	5.27	112	150	84	2.09	5.27	338	110	86	4.52	5.27	84	159	83	1.69	5.27
	11.	11.61	125	149	84	2.32	5.27	83	163	83	1.70	5.27	250	125	86	3.80	5.27	62	172	82	1.37	5.27
	12.	13.20	110	154	84	2.11	5.27	73	167	82	1.55	5.27	220	131	86	3.50	5.27	55	177	81	1.26	5.27
	14.	14.95	97	159	83	1.95	5.27	64	173	82	1.42	5.27	194	136	85	3.25	5.27	48	183	81	1.15	5.27
	16.	16.36	89	144	75	1.78	5.27	59	158	73	1.33	5.27	177	114	77	2.75	5.27	44	168	72	1.08	5.27
	18.	19.12	76	168	82	1.63	5.27	50	183	82	1.17	5.27	152	145	85	2.71	5.27	38	194	80	0.96	5.27
	20.	20.61	70	171	82	1.54	5.27	47	187	81	1.13	5.27	141	148	84	2.60	5.27	35	198	80	0.91	5.27
	22.	22.11	66	156	74	1.45	5.27	43	170	72	1.07	5.27	131	129	76	2.33	5.27	33	181	71	0.88	5.27
	25.	25.14	58	161	73	1.33	5.27	38	175	71	0.99	5.27	115	135	76	2.15	5.27	29	186	70	0.80	5.27
	28.	28.48	51	167	72	1.24	5.27	34	181	71	0.90	5.27	102	142	75	2.02	5.27	25	192	69	0.74	5.27
	32.	33.71	43	192	80	1.08	5.27	28	209	79	0.79	5.27	86	167	83	1.81	5.27	22	207	78	0.60	5.27
	36.	36.43	40	176	71	1.03	5.27	26	192	69	0.77	5.27	80	152	75	1.69	5.27	20	203	68	0.62	5.27
	40.	39.26	37	179	71	0.98	5.27	24	196	69	0.73	5.27	74	155	74	1.62	5.27	18	208	68	0.59	5.27
	45.	45.50	32	206	79	0.87	5.27	21	207	78	0.59	5.27	64	179	82	1.46	5.27	16	205	77	0.44	5.27
	50.	53.31	27	209	79	0.75	5.27	18	206	78	0.50	5.27	54	185	81	1.30	5.27	14	204	77	0.38	5.27
	56.	56.19	26	196	69	0.77	5.27	17	213	67	0.57	5.27	52	171	72	1.28	5.27	13	227	66	0.46	5.27
	63.	64.21	23	202	68	0.70	5.27	15	220	67	0.51	5.27	45	176	72	1.16	5.27	11	238	66	0.43	5.27
	71.	74.55	19	206	77	0.54	5.27	13	203	76	0.36	5.27	39	211	80	1.07	5.27	10	201	76	0.27	5.27
	80.	82.83	18	192	77	0.46	5.27	12	189	76	0.30	5.27	35	197	79	0.91	5.27	8.8	187	75	0.23	5.27
	90.	86.67	17	227	67	0.59	5.27	11	247	65	0.44	5.27	33	199	70	1.00	5.27	8.4	263	64	0.36	5.27
	100	101.5	14	234	66	0.53	5.27	9.5	255	65	0.39	5.27	29	204	69	0.88	5.27	7.1	277	64	0.32	5.27
	112	114.3	13	130	76	0.23	5.27	8.4	129	75	0.15	5.27	25	134	78	0.46	5.27	6.3	127	74	0.11	5.27
	125	129.0	11	128	76	0.20	5.27	7.4	126	74	0.13	5.27	22	131	78	0.40	5.27	5.6	125	74	0.10	5.27
	140	142.0	10	252	65	0.41	5.27	6.8	278	63	0.31	5.27	20	218	68	0.69	5.27	5.1	278	62	0.24	5.27
	160	157.8	9.2	257	64	0.39	5.27	6.1	278	63	0.28	5.27	18	223	67	0.64	5.27	4.6	278	62	0.22	5.27
212	217.8	6.7	206	63	0.23	5.27	4.4	201	61	0.15	5.27	13	214	65	0.46	5.27	3.3	198	61	0.11	5.27	
250	247.5	5.9	201	63	0.20	5.27	3.9	196	61	0.13	5.27	12	209	65	0.39	5.27	2.9	194	60	0.099	5.27	
C0431	100	105.4	14	204	76	0.39	5.27	9.1	201	75	0.26	5.27	28	209	77	0.78	5.27	6.9	199	74	0.19	5.27
	118	120.4	12	203	75	0.34	5.27	8.0	200	74	0.23	5.27	24	208	77	0.68	5.27	6.0	198	73	0.17	5.27
	132	130.1	11	239	64	0.44	5.27	7.4	274	63	0.34	5.27	22	197	66	0.70	5.27	5.6	278	62	0.26	5.27
	150	140.2	10	245	64	0.41	5.27	6.8	278	63	0.32	5.27	21	200	66	0.66	5.27	5.2	278	62	0.24	5.27
	160	162.5	8.9	201	75	0.25	5.27	5.9	198	73	0.17	5.27	18	206	76	0.51	5.27	4.5	197	73	0.13	5.27
	180	190.4	7.6	200	74	0.22	5.27	5.0	197	73	0.14	5.27	15	205	76	0.43	5.27	3.8	196	72	0.11	5.27
	200	200.7	7.2	276	63	0.33	5.27	4.8	278	61	0.23	5.27	14	219	64	0.52	5.27	3.6	278	60	0.18	5.27
	225	229.3	6.3	278	62	0.30	5.27	4.2	278	61	0.20	5.27	13	229	64	0.47	5.27	3.2	278	60	0.15	5.27
	265	266.2	5.4	198	73	0.15	5.27	3.6	195	72	0.10	5.27	11	202	74	0.31	5.27	2.7	194	72	0.08	5.27
	280	295.8	4.9	197	73	0.14	5.27	3.2	195	72	0.09	5.27	10	201	74	0.28	5.27	2.5	194	72	0.07	5.27
	315	309.5	4.7	278	61	0.22	5.27	3.1	278	60	0.15	5.27	9.4	253	63	0.39	5.27	2.3	278	59	0.12	5.27
	360	362.6	4.0	278	61	0.19	5.27	2.6	278	59	0.13	5.27	8.0	267	63	0.35	5.27	2.0	278	59	0.10	5.27
	400	408.3	3.6	195	72	0.10	5.27	2.4	193	71	0.067	5.27	7.1	199	73	0.20	5.27	1.8	192	71	0.050	5.27
	450	464.1	3.1	195	72	0.089	5.27	2.1	193	71	0.059	5.27	6.2	199	73	0.18	5.27	1.6	192	71	0.044	5.27
	500	507.1	2.9	278	59	0.141	5.27	1.9	278	59	0.093	5.27	5.7	278	61	0.27	5.27	1.4	278	58	0.072	5.27
	560	563.5	2.6	278	59	0.127	5.27	1.7	278	58	0.086	5.27	5.1	278	61	0.25	5.27	1.3	278	58	0.065	5.27
800	777.8	1.9	278	58	0.094	5.27	1.2	278	57	0.063	5.27	3.7	278	60	0.18	5.27	0.93	278	57	0.048	5.27	
900	883.9	1.6	278	58	0.082	5.27	1.1	278	57	0.055	5.27	3.3	278	60	0.16	5.27	0.82	278	57	0.042	5.27	
C0441	10C	960	1.5	208	71	0.046	5.27	1.0	208	71	0.031	5.27	3.0	208	71	0.093	5.27	0.76	208	71	0.023	5.27
	11C	1097	1.3	208	71	0.041	5.27	0.88	208	71	0.027	5.27	2.6	208	71	0.081	5.27	0.66	208	71	0.020	5.27
	12C	1220	1.2	208	71	0.036	5.27	0.79	208	71	0.024	5.27	2.4	208	71	0.073	5.27	0.59	208	71	0.018	5.27
	14C	1345	1.1	206	70	0.033	5.27	0.71	206	70	0.022	5.27	2.2	206	70	0.066	5.27	0.54	206	70	0.017	5.27
	16C	1635	0.89	192	70	0.025	5.27	0.59	192	70	0.017	5.27	1.8	192	70	0.051	5.27	0.44	192	70	0.013	5.27
	18C	1735	0.84	206	70	0.026	5.27	0.55	206	70	0.017	5.27	1.7	206	70	0.052	5.27	0.42	206	70	0.013	5.27
	20C	1916	0.76	192	70	0.022	5.27	0.50	192	70	0.014	5.27	1.5	192	70	0.043	5.27	0.38	192	70	0.011	5.27
	22C	2081	0.70	206	70	0.021	5.27	0.46	206	70	0.014	5.27	1.4	206	70	0.043	5.27	0.35	206	70	0.011	5.27
	25C	2426	0.60	206	70	0.018	5.27	0.40	206	70	0.012	5.27	1.2	206	70	0.037	5.27	0.30	206	70	0.009	5.27
	28C	2679	0.54	192	70	0.016	5.27	0.36	192	70	0.010	5.27	1.1	192	70	0.031	5.27	0.27	192	70	0.008	5.27
	32C	3246	0.45	206	70	0.014	5.27	0.30	206	70	0.009	5.27	0.89	206	70	0.028	5.27	0.22	206	70	0.007	5.27
	36C	3585	0.40	192	70	0.012	5.27	0.27	192	70	0.008	5.27	0.81	192	70	0.023	5.27	0.20	192	70	0.006	5.27
	40C	4109	0.35	192	70	0.010	5.27	0.23	192	70	0.007	5.27	0.71	192	70	0.020	5.27	0.18	192	70	0.005	5.27
	45C	4670	0.31	192	70	0.009	5.27	0.21	192	70	0.006	5.27	0.62	192	70	0.018	5.27	0.16	192	70	0.004	5.27
	50C	4978	0.29	278	69	0.012	5.27	0.19	278	69	0.008	5.27	0.58	278	69	0.025	5.27	0.15	278	69	0.006	5.27
	56C	5658	0.26	278	69	0.011	5.27	0.17	278	69	0.007	5.27	0.51	278	69	0.022	5.27	0.13	278	69	0.005	5.27
	63C	6485	0.22	278	69	0.009	5.27	0.15	278	69	0.006	5.27	0.45	278	69	0.019	5.27	0.11	278	69	0.005	5.27
	71C	7370	0.20	278	69	0.008	5.27	0.13	278	69	0.005	5.27	0.39	278	69	0.017	5.27	0.10	278	69	0.004	5.27
	80C	7874	0.18	278	54	0.010																

SERIES C

RATINGS

Key: Pm= Input Power (kW) M2= Output Torque (Nm) i= Exact Ratio n2= Output Speed (rpm) Fra = Overhung load (kN)

			n1 = 1450					n1 = 960					n1 = 2900					n1 = 725				
	<i>h</i>	<i>i</i>	n2	M2	η (%)	Pm	Fra	n2	M2	η (%)	Pm	Fra	n2	M2	η (%)	Pm	Fra	n2	M2	η (%)	Pm	Fra
C0521	8.0	8.31	174	209	88	4.34	7.41	115	243	85	3.46	7.41	349	154	87	6.47	7.41	87	241	85	2.59	7.41
	11.	11.66	124	238	86	3.60	7.41	82	277	85	2.81	7.41	249	179	87	5.36	7.41	62	306	84	2.37	7.41
	12.	12.85	113	247	85	3.43	7.41	75	287	84	2.67	7.41	226	187	87	5.08	7.41	56	316	84	2.22	7.41
	14.	14.59	99	259	85	3.17	7.41	66	300	84	2.46	7.41	199	197	87	4.71	7.41	50	329	83	2.06	7.41
	16.	16.09	90	320	78	3.87	7.41	60	348	76	2.86	7.41	180	250	81	5.82	7.41	45	367	75	2.31	7.41
	18.	18.53	78	282	84	2.75	7.41	52	325	83	2.12	7.41	157	218	86	4.15	7.41	39	355	82	1.77	7.41
	20.	21.05	69	295	84	2.53	7.41	46	338	82	1.97	7.41	138	229	86	3.84	7.41	34	370	82	1.63	7.41
	22.	22.56	64	345	77	3.02	7.41	43	372	74	2.24	7.41	129	287	79	4.89	7.41	32	393	73	1.81	7.41
	25.	24.86	58	352	76	2.83	7.41	39	380	74	2.08	7.41	117	298	79	4.61	7.41	29	401	72	1.70	7.41
	28.	28.24	51	362	75	2.60	7.41	34	389	73	1.90	7.41	103	311	79	4.23	7.41	26	411	72	1.53	7.41
	32.	32.55	45	341	82	1.94	7.41	29	387	81	1.48	7.41	89	270	85	2.96	7.41	22	408	81	1.17	7.41
	36.	35.86	40	378	74	2.16	7.41	27	409	72	1.59	7.41	81	331	77	3.64	7.41	20	431	71	1.29	7.41
	40.	40.74	36	388	73	1.98	7.41	24	420	71	1.46	7.41	71	341	77	3.30	7.41	18	443	70	1.18	7.41
	45.	46.84	31	382	81	1.53	7.41	20	406	80	1.09	7.41	62	306	83	2.39	7.41	15	402	79	0.825	7.41
	50.	50.93	28	391	81	1.44	7.41	19	405	80	0.999	7.41	57	315	83	2.26	7.41	14.2	401	79	0.757	7.41
	56.	55.45	26	415	72	1.58	7.41	17	449	70	1.16	7.41	52	368	75	2.69	7.41	13.1	474	69	0.941	7.41
	63.	63.00	23	427	71	1.45	7.41	15	461	69	1.07	7.41	46	378	74	2.46	7.41	11.5	482	68	0.854	7.41
	71.	73.37	20	406	79	1.06	7.41	13	400	78	0.703	7.41	40	354	81	1.81	7.41	9.9	396	78	0.525	7.41
	80.	82.67	18	404	79	0.94	7.41	12	398	78	0.620	7.41	35	367	81	1.66	7.41	8.8	395	77	0.471	7.41
	90.	90.67	16	478	70	1.14	7.41	11	482	68	0.786	7.41	32	424	72	1.97	7.41	8.0	482	66	0.611	7.41
	100	98.57	15	482	69	1.08	7.41	9.7	482	67	0.734	7.41	29	429	72	1.84	7.41	7.4	482	66	0.562	7.41
	112	109.1	13	393	78	0.701	7.41	8.8	388	77	0.464	7.41	27	399	81	1.37	7.41	6.6	384	77	0.347	7.41
	125	124.0	12	386	78	0.606	7.41	7.7	381	77	0.401	7.41	23	391	80	1.20	7.41	5.8	378	76	0.305	7.41
	140	142.0	10	482	67	0.769	7.41	6.8	482	65	0.525	7.41	20	455	70	1.39	7.41	5.1	482	65	0.396	7.41
	160	160.0	9.1	482	67	0.683	7.41	6.0	482	65	0.466	7.41	18	466	70	1.26	7.41	4.5	482	64	0.357	7.41
212	211.1	6.9	482	66	0.525	7.41	4.5	482	64	0.359	7.41	14	482	68	1.02	7.41	3.4	482	63	0.275	7.41	
250	240.0	6.0	482	65	0.469	7.41	4.0	482	63	0.320	7.41	12	482	68	0.897	7.41	3.0	482	63	0.242	7.41	
C0531	100	103.9	14	401	78	0.751	7.41	9.2	395	77	0.496	7.41	28	393	79	1.454	7.41	7.0	392	76	0.377	7.41
	118	118.7	12	399	77	0.663	7.41	8.1	394	77	0.433	7.41	24	408	79	1.321	7.41	6.1	390	76	0.328	7.41
	132	130.4	11	482	67	0.838	7.41	7.4	482	65	0.572	7.41	22	413	69	1.394	7.41	5.6	482	64	0.438	7.41
	150	140.5	10	482	66	0.789	7.41	6.8	482	65	0.531	7.41	21	419	69	1.312	7.41	5.2	482	64	0.407	7.41
	160	160.3	9.0	395	77	0.486	7.41	6.0	390	76	0.322	7.41	18	405	78	0.984	7.41	4.5	387	75	0.244	7.41
	180	187.8	7.7	393	76	0.418	7.41	5.1	388	75	0.277	7.41	15	402	78	0.833	7.41	3.9	386	75	0.208	7.41
	200	201.1	7.2	482	65	0.560	7.41	4.8	482	64	0.376	7.41	14	453	68	1.006	7.41	3.6	482	63	0.289	7.41
	225	229.8	6.3	482	65	0.490	7.41	4.2	482	63	0.335	7.41	13	471	67	0.929	7.41	3.2	482	62	0.257	7.41
	265	262.6	5.5	389	75	0.300	7.41	3.7	385	74	0.199	7.41	11	398	77	0.598	7.41	2.8	382	74	0.149	7.41
	280	291.8	5.0	388	75	0.269	7.41	3.3	385	74	0.179	7.41	9.9	396	76	0.542	7.41	2.5	381	73	0.136	7.41
	315	310.2	4.7	482	63	0.374	7.41	3.1	482	62	0.252	7.41	9.3	482	66	0.715	7.41	2.3	482	61	0.193	7.41
	360	363.4	4.0	482	63	0.320	7.41	2.6	482	62	0.215	7.41	8.0	482	65	0.620	7.41	2.0	482	61	0.165	7.41
	400	402.7	3.6	385	74	0.196	7.41	2.4	381	74	0.129	7.41	7.2	392	75	0.394	7.41	1.8	379	73	0.098	7.41
	450	457.7	3.2	384	74	0.172	7.41	2.1	380	73	0.114	7.41	6.3	391	75	0.346	7.41	1.6	377	73	0.086	7.41
	500	508.2	2.9	482	62	0.232	7.41	1.9	482	61	0.156	7.41	5.7	482	64	0.450	7.41	1.4	482	60	0.120	7.41
560	564.7	2.6	482	61	0.212	7.41	1.7	482	60	0.143	7.41	5.1	482	63	0.411	7.41	1.3	482	59	0.110	7.41	
800	779.4	1.9	482	61	0.154	7.41	1.2	482	60	0.104	7.41	3.7	482	62	0.303	7.41	0.93	482	59	0.080	7.41	
900	885.8	1.6	482	60	0.138	7.41	1.1	482	59	0.093	7.41	3.3	482	62	0.267	7.41	0.82	482	59	0.070	7.41	
C0541	10C	945	1.5	406	73	0.089	7.41	1.0	406	73	0.059	7.41	3.1	406	73	0.179	7.41	0.77	406	73	0.045	7.41
	11C	1080	1.3	406	73	0.078	7.41	0.89	406	73	0.052	7.41	2.7	406	73	0.156	7.41	0.67	406	73	0.039	7.41
	12C	1201	1.2	406	73	0.070	7.41	0.80	406	73	0.047	7.41	2.4	406	73	0.141	7.41	0.60	406	73	0.035	7.41
	14C	1324	1.1	406	73	0.064	7.41	0.73	406	73	0.042	7.41	2.2	406	73	0.128	7.41	0.55	406	73	0.032	7.41
	16C	1642	0.88	404	72	0.052	7.41	0.58	404	72	0.034	7.41	1.8	404	72	0.104	7.41	0.44	404	72	0.026	7.41
	18C	1707	0.85	406	73	0.049	7.41	0.56	406	73	0.033	7.41	1.7	406	73	0.099	7.41	0.42	406	73	0.025	7.41
	20C	1924	0.75	404	72	0.044	7.41	0.50	404	72	0.029	7.41	1.5	404	72	0.089	7.41	0.38	404	72	0.022	7.41
	22C	2048	0.71	406	73	0.041	7.41	0.47	406	73	0.027	7.41	1.4	406	73	0.082	7.41	0.35	406	73	0.021	7.41
	25C	2387	0.61	406	73	0.035	7.41	0.40	406	73	0.023	7.41	1.2	406	73	0.071	7.41	0.30	406	73	0.018	7.41
	28C	2690	0.54	404	72	0.032	7.41	0.36	404	72	0.021	7.41	1.1	404	72	0.063	7.41	0.27	404	72	0.016	7.41
	32C	3195	0.45	406	73	0.026	7.41	0.30	406	73	0.017	7.41	0.91	406	73	0.053	7.41	0.23	406	73	0.013	7.41
	36C	3599	0.40	404	72	0.024	7.41	0.27	404	72	0.016	7.41	0.81	404	72	0.047	7.41	0.20	404	72	0.012	7.41
	40C	4126	0.35	404	72	0.021	7.41	0.23	404	72	0.014	7.41	0.70	404	72	0.041	7.41	0.18	404	72	0.010	7.41
	45C	4689	0.31	404	72	0.018	7.41	0.20	404	72	0.012	7.41	0.62	404	72	0.036	7.41	0.15	404	72	0.009	7.41
	50C	4778	0.30	393	71	0.018	7.41	0.20	393	71	0.012	7.41	0.61	393	71	0.035	7.41	0.15	393	71	0.009	7.41
	56C	5399	0.27	386	71	0.015	7.41	0.18	386	71	0.010	7.41	0.54	386	71	0.031	7.41	0.13	386	71	0.008	7.41
	63C	6189	0.23	386	71	0.013	7.41	0.16	386	71	0.009	7.41	0.47	386	71	0.027	7.41	0.12	386	71	0.007	7.41
71C	7033	0.21	386	71	0.012	7.41	0.14	386	71	0.008	7.41	0.41	386	71	0.023	7.41	0.					

SERIES C

RATINGS

Key: Pm= Input Power (kW) M2= Output Torque (Nm) i= Exact Ratio n2= Output Speed (rpm) Fra = Overhung load (kN)

			n1 = 1450					n1 = 960					n1 = 2900					n1 = 725				
	<i>n</i>	<i>i</i>	n2	M2	η (%)	Pm	Fra	n2	M2	η (%)	Pm	Fra	n2	M2	η (%)	Pm	Fra	n2	M2	η (%)	Pm	Fra
C0621	8.0	8.2	176	372	90	7.62	11.4	117	439	90	5.96	11.4	352	273	90	11.19	11.4	88.1	487	89	5.05	11.4
	11.	11.6	125	427	89	6.30	11.4	83.0	498	89	4.86	11.4	251	319	90	9.30	11.4	62.7	550	88	4.10	11.4
	12.	13.0	112	446	89	5.87	11.4	74.0	519	88	4.57	11.4	224	336	90	8.74	11.4	55.9	572	88	3.80	11.4
	14.	14.6	99.6	466	89	5.46	11.4	65.9	540	88	4.24	11.4	199	353	90	8.18	11.4	49.8	595	87	3.57	11.4
	16.	15.9	91.0	517	82	6.01	11.4	60.3	582	80	4.59	11.4	182	389	82	9.04	11.4	45.5	613	79	3.70	11.4
	18.	18.5	78.4	508	88	4.74	11.4	51.9	587	87	3.67	11.4	157	390	89	7.20	11.4	39.2	644	87	3.04	11.4
	20.	21.0	69.2	531	88	4.37	11.4	45.8	612	87	3.37	11.4	138	410	89	6.67	11.4	34.6	670	86	2.82	11.4
	22.	22.4	64.7	579	81	4.85	11.4	42.9	624	79	3.54	11.4	129	450	82	7.44	11.4	32.4	655	78	2.85	11.4
	25.	25.1	57.7	594	80	4.49	11.4	38.2	636	78	3.26	11.4	115	471	82	6.95	11.4	28.9	671	77	2.63	11.4
	28.	28.2	51.5	611	80	4.12	11.4	34.1	652	78	2.98	11.4	103	493	81	6.56	11.4	25.7	688	77	2.41	11.4
	32.	33.5	43.3	623	87	3.25	11.4	28.7	709	86	2.48	11.4	86.6	490	88	5.05	11.4	21.7	766	85	2.04	11.4
	36.	35.8	40.5	637	78	3.46	11.4	26.8	686	76	2.54	11.4	81.0	541	81	5.67	11.4	20.3	724	75	2.05	11.4
	40.	40.6	35.7	651	78	3.12	11.4	23.7	705	76	2.30	11.4	71.5	567	81	5.24	11.4	17.9	743	75	1.85	11.4
	45.	47.3	30.6	695	86	2.59	11.4	20.3	766	85	1.91	11.4	61.3	554	87	4.09	11.4	15.3	766	84	1.46	11.4
	50.	50.5	28.7	709	86	2.48	11.4	19.0	766	84	1.81	11.4	57.4	567	87	3.92	11.4	14.4	766	83	1.39	11.4
	56.	55.7	26.0	698	76	2.50	11.4	17.2	755	74	1.84	11.4	52.1	623	79	4.30	11.4	13.0	766	73	1.43	11.4
	63.	64.8	22.4	721	75	2.25	11.4	14.8	766	73	1.63	11.4	44.8	642	79	3.81	11.4	11.2	766	72	1.25	11.4
	71.	73.9	19.6	766	84	1.87	11.4	13.0	766	83	1.26	11.4	39.2	644	86	3.08	11.4	9.8	766	82	0.959	11.4
	80.	80.9	17.9	766	84	1.71	11.4	11.9	766	83	1.15	11.4	35.8	663	86	2.89	11.4	9.0	766	82	0.876	11.4
	90.	91.6	15.8	766	74	1.72	11.4	10.5	766	72	1.17	11.4	31.7	720	77	3.10	11.4	7.9	766	70	0.907	11.4
	100	97.8	14.8	766	73	1.63	11.4	9.8	766	72	1.09	11.4	29.7	726	77	2.93	11.4	7.4	766	70	0.850	11.4
	112	110.6	13.1	748	83	1.24	11.4	8.7	739	82	0.819	11.4	26.2	728	85	2.35	11.4	6.6	733	81	0.621	11.4
	125	124.0	11.7	530	82	0.791	11.4	7.7	523	81	0.523	11.4	23.4	541	84	1.58	11.4	5.8	519	80	0.397	11.4
	140	143.1	10.1	766	71	1.14	11.4	6.7	766	69	0.780	11.4	20.3	766	75	2.17	11.4	5.1	766	68	0.598	11.4
	160	156.7	9.3	766	71	1.05	11.4	6.1	766	69	0.712	11.4	18.5	766	74	2.01	11.4	4.6	766	68	0.546	11.4
212	214.0	6.8	766	69	0.788	11.4	4.5	766	68	0.529	11.4	13.6	766	72	1.51	11.4	3.4	766	66	0.412	11.4	
250	240.0	6.0	766	69	0.702	11.4	4.0	766	67	0.479	11.4	12.1	766	72	1.35	11.4	3.0	766	66	0.367	11.4	
C0631	100	103.9	14.0	766	82	1.37	11.4	9.2	766	81	0.915	11.4	27.9	715	84	2.49	11.4	7.0	766	81	0.69	11.4
	118	118.0	12.3	766	82	1.20	11.4	8.1	766	81	0.806	11.4	24.6	742	84	2.27	11.4	6.1	766	80	0.62	11.4
	132	130.0	11.2	766	71	1.26	11.4	7.4	766	69	0.858	11.4	22.3	695	73	2.22	11.4	5.6	766	68	0.66	11.4
	150	147.7	9.8	766	70	1.12	11.4	6.5	766	69	0.756	11.4	19.6	712	73	2.01	11.4	4.9	766	68	0.58	11.4
	160	169.8	8.5	766	81	0.846	11.4	5.7	766	80	0.567	11.4	17.1	766	83	1.65	11.4	4.3	766	79	0.43	11.4
	180	184.6	7.9	766	81	0.778	11.4	5.2	766	80	0.521	11.4	15.7	766	82	1.54	11.4	3.9	766	79	0.40	11.4
	200	201.0	7.2	766	69	0.839	11.4	4.8	766	67	0.572	11.4	14.4	766	72	1.61	11.4	3.6	766	66	0.44	11.4
	225	228.4	6.3	766	68	0.749	11.4	4.2	766	67	0.503	11.4	12.7	766	71	1.43	11.4	3.2	766	66	0.39	11.4
	265	266.0	5.5	766	80	0.547	11.4	3.6	766	79	0.366	11.4	10.9	766	81	1.08	11.4	2.7	766	78	0.28	11.4
	280	299.7	4.8	766	79	0.491	11.4	3.2	766	78	0.329	11.4	9.7	766	81	0.958	11.4	2.4	766	78	0.249	11.4
	315	328.7	4.4	766	67	0.528	11.4	2.9	766	65	0.360	11.4	8.8	766	69	1.03	11.4	2.2	766	64	0.28	11.4
	360	357.3	4.1	766	66	0.493	11.4	2.7	766	65	0.332	11.4	8.1	766	69	0.943	11.4	2.0	766	64	0.25	11.4
	400	395.4	3.7	766	79	0.372	11.4	2.4	766	78	0.250	11.4	7.3	766	80	0.735	11.4	1.8	766	77	0.191	11.4
	450	449.5	3.2	766	78	0.332	11.4	2.1	766	78	0.220	11.4	6.5	766	80	0.647	11.4	1.6	766	77	0.168	11.4
	500	514.8	2.8	766	65	0.348	11.4	1.9	766	64	0.234	11.4	5.6	766	67	0.674	11.4	1.4	766	63	0.179	11.4
	560	580.0	2.5	766	64	0.313	11.4	1.7	766	63	0.211	11.4	5.0	766	67	0.599	11.4	1.3	766	62	0.162	11.4
	800	765.3	1.9	766	64	0.237	11.4	1.3	766	63	0.160	11.4	3.8	766	66	0.461	11.4	0.95	766	62	0.123	11.4
900	870.0	1.7	766	63	0.212	11.4	1.1	766	62	0.143	11.4	3.3	766	65	0.411	11.4	0.83	766	61	0.110	11.4	
C0641	10C	1022	1.4	766	77	0.148	11.4	0.94	766	77	0.098	11.4	2.8	766	77	0.296	11.4	0.71	766	77	0.074	11.4
	11C	1111	1.3	766	77	0.136	11.4	0.86	766	77	0.090	11.4	2.6	766	77	0.272	11.4	0.65	766	77	0.068	11.4
	12C	1300	1.1	766	77	0.116	11.4	0.74	766	77	0.077	11.4	2.2	766	77	0.232	11.4	0.56	766	77	0.058	11.4
	14C	1495	1.0	766	77	0.101	11.4	0.64	766	77	0.067	11.4	1.9	766	77	0.202	11.4	0.48	766	77	0.051	11.4
	16C	1625	0.9	766	77	0.093	11.4	0.59	766	77	0.062	11.4	1.8	766	77	0.186	11.4	0.45	766	77	0.046	11.4
	18C	1780	0.8	766	76	0.086	11.4	0.54	766	76	0.057	11.4	1.6	766	76	0.172	11.4	0.41	766	76	0.043	11.4
	20C	1951	0.74	766	77	0.077	11.4	0.49	766	77	0.051	11.4	1.5	766	77	0.155	11.4	0.37	766	77	0.039	11.4
	22C	2342	0.62	766	77	0.064	11.4	0.41	766	77	0.043	11.4	1.2	766	77	0.129	11.4	0.31	766	77	0.032	11.4
	25C	2638	0.55	766	77	0.057	11.4	0.36	766	77	0.038	11.4	1.1	766	77	0.115	11.4	0.27	766	77	0.029	11.4
	28C	2889	0.50	766	76	0.053	11.4	0.33	766	76	0.035	11.4	1.0	766	76	0.106	11.4	0.25	766	76	0.026	11.4
	32C	3067	0.47	766	77	0.049	11.4	0.31	766	77	0.033	11.4	0.95	766	77	0.098	11.4	0.24	766	77	0.025	11.4
	36C	3359	0.43	766	76	0.046	11.4	0.29	766	76	0.030	11.4	0.86	766	76	0.091	11.4	0.22	766	76	0.023	11.4
	40C	3812	0.38	766	76	0.040	11.4	0.25	766	76	0.027	11.4	0.76	766	76	0.080	11.4	0.19	766	76	0.020	11.4
	45C	4334	0.33	766	76	0.035	11.4	0.22	766	76	0.023	11.4	0.67	766	76	0.071	11.4	0.17	766	76	0.018	11.4
	50C	5145	0.28	766	76	0.030	11.4	0.19	766	76	0.020	11.4	0.56	766	76	0.059	11.4	0.14	766	76	0.015	11.4
	56C	5920	0.24	766	76	0.026	11.4	0.16	766	76	0.017	11.4	0.49	766	76	0.052	11.4	0.12	766	76	0.013	11.4
	63C	6639	0.22	766	76	0.023	11.4	0.14	766	76	0.015	11.4	0.44	766	76	0.046	11.4	0.11	766	76	0.012	11.4
71C	7378	0.20	766	58																		

SERIES C

RATINGS

Key: Pm= Input Power (kW) M2= Output Torque (Nm) i= Exact Ratio n2= Output Speed (rpm) Fra = Overhung load (kN)

			n1 = 1450					n1 = 960					n1 = 2900					n1 = 725				
	<i>n</i>	<i>i</i>	n2	M2	η (%)	Pm	Fra	n2	M2	η (%)	Pm	Fra	n2	M2	η (%)	Pm	Fra	n2	M2	η (%)	Pm	Fra
C0721	8.0	7.901	183.5	618	92	12.9	20.7	121.5	615	92	8.50	22.7	367.0	468	92	19.55	0.0	91.8	612	91	6.46	24.8
	11.	10.94	132.5	734	92	11.1	22.1	87.8	849	91	8.57	24.0	265.1	546	92	16.47	0.0	66.3	843	91	6.43	25.3
	12.	12.29	118.0	768	92	10.3	22.7	78.1	896	91	8.05	24.8	236.0	576	92	15.47	0.0	59.0	944	91	6.41	26.9
	14.	13.52	107.2	796	92	9.72	23.4	71.0	927	91	7.57	25.5	214.5	600	92	14.65	0.0	53.6	1020	90	6.36	26.9
	16.	15.80	91.8	716	88	7.82	25.5	60.8	798	88	5.77	26.9	183.5	586	88	12.80	20.7	45.9	851	87	4.70	26.9
	18.	17.66	82.1	879	91	8.30	26.9	54.4	1020	90	6.45	26.9	164.2	673	92	12.58	26.9	41.1	1120	90	5.35	26.9
	20.	20.07	72.2	921	91	7.66	26.9	47.8	1060	90	5.90	26.9	144.5	709	92	11.66	26.9	36.1	1170	90	4.92	26.9
	22.	21.89	66.2	781	88	6.16	26.9	43.9	860	87	4.54	26.9	132.5	648	88	10.22	26.9	33.1	911	86	3.67	26.9
	25.	24.59	59.0	803	87	5.70	26.9	39.0	881	86	4.19	26.9	117.9	669	87	9.50	26.9	29.5	931	85	3.38	26.9
	28.	27.03	53.6	822	87	5.31	26.9	35.5	898	86	3.88	26.9	107.3	685	87	8.85	26.9	26.8	948	85	3.13	26.9
	32.	30.81	47.1	1070	90	5.86	26.9	31.2	1220	89	4.47	26.9	94.1	836	91	9.05	26.9	23.5	1330	88	3.72	26.9
	36.	35.31	41.1	872	86	4.36	26.9	27.2	946	85	3.17	26.9	82.1	738	87	7.30	26.9	20.5	993	84	2.54	26.9
	40.	40.15	36.1	895	86	3.94	26.9	23.9	967	84	2.88	26.9	72.2	764	87	6.64	26.9	18.1	1010	83	2.30	26.9
	45.	44.13	32.9	1200	89	4.64	26.9	21.8	1340	88	3.47	26.9	65.7	953	90	7.29	26.9	16.4	1340	87	2.65	26.9
	50.	49.90	29.1	1250	88	4.32	26.9	19.2	1340	87	3.10	26.9	58.1	995	90	6.73	26.9	14.5	1340	87	2.34	26.9
	56.	53.62	27.0	946	85	3.15	26.9	17.9	1010	83	2.28	26.9	54.1	820	86	5.40	26.9	13.5	1070	83	1.83	26.9
	63.	61.62	23.5	970	84	2.85	26.9	15.6	1040	83	2.04	26.9	47.1	847	86	4.85	26.9	11.8	1100	83	1.63	26.9
	71.	69.00	21.0	1340	87	3.39	26.9	13.9	1340	86	2.27	26.9	42.0	1110	89	5.49	26.9	10.5	1340	86	1.71	26.9
	80.	75.56	19.2	1340	87	3.09	26.9	12.7	1340	86	2.07	26.9	38.4	1140	88	5.21	26.9	9.6	1340	85	1.58	26.9
	90.	88.26	16.4	1030	83	2.13	26.9	10.9	1110	82	1.54	26.9	32.9	912	85	3.69	26.9	8.2	1170	81	1.24	26.9
	100	99.79	14.5	1050	82	1.95	26.9	9.6	1140	81	1.42	26.9	29.1	934	84	3.38	26.9	7.3	1190	80	1.13	26.9
	112	104.3	13.9	1340	86	2.27	26.9	9.2	1330	85	1.51	26.9	27.8	1260	87	4.22	26.9	7.0	1320	84	1.14	26.9
	125	115.9	12.5	1140	85	1.76	26.9	8.3	1130	84	1.17	26.9	25.0	1160	87	3.49	26.9	6.3	1120	84	0.87	26.9
	140	138.0	10.5	1120	81	1.52	26.9	7.0	1200	80	1.09	26.9	21.0	989	83	2.62	26.9	5.3	1250	79	0.87	26.9
	160	151.1	9.6	1140	81	1.41	26.9	6.4	1220	80	1.01	26.9	19.2	1000	83	2.42	26.9	4.8	1270	79	0.81	26.9
212	208.6	7.0	1200	79	1.11	26.9	4.6	1270	78	0.78	26.9	13.9	1060	82	1.88	26.9	3.5	1270	78	0.59	26.9	
250	231.8	6.3	1220	79	1.01	26.9	4.1	1270	78	0.71	26.9	12.5	1080	81	1.747	26.9	3.1	1270	77	0.54	26.9	
C0731	100	97.33	14.9	1340	86	2.43	26.9	9.9	1340	85	1.63	26.9	29.8	1240	87	4.447	26.9	7.4	1340	85	1.23	26.9
	118	113.2	12.8	1340	85	2.11	26.9	8.5	1340	84	1.42	26.9	25.6	1300	87	4.008	26.9	6.4	1340	84	1.07	26.9
	132	125.0	11.6	1100	80	1.67	26.9	7.7	1180	79	1.20	26.9	23.2	973	81	2.918	26.9	5.8	1230	78	0.96	26.9
	150	141.7	10.2	1120	79	1.52	26.9	6.8	1210	79	1.09	26.9	20.5	993	81	2.627	26.9	5.1	1260	78	0.87	26.9
	160	160.0	9.1	1340	84	1.51	26.9	6.0	1340	83	1.01	26.9	18.1	1340	86	2.957	26.9	4.5	1340	83	0.77	26.9
	180	170.8	8.5	1340	84	1.42	26.9	5.6	1340	83	0.95	26.9	17.0	1340	85	2.803	26.9	4.2	1340	83	0.72	26.9
	200	194.7	7.4	1190	79	1.17	26.9	4.9	1270	78	0.84	26.9	14.9	1040	80	2.028	26.9	3.7	1270	77	0.64	26.9
	225	226.4	6.4	1220	79	1.04	26.9	4.2	1270	77	0.73	26.9	12.8	1080	80	1.811	26.9	3.2	1270	77	0.55	26.9
	265	249.9	5.8	1340	83	0.98	26.9	3.8	1340	82	0.66	26.9	11.6	1340	84	1.938	26.9	2.9	1340	82	0.50	26.9
	280	273.7	5.3	1340	83	0.90	26.9	3.5	1340	82	0.60	26.9	10.6	1340	84	1.770	26.9	2.6	1340	82	0.45	26.9
	315	320.0	4.5	1270	77	0.78	26.9	3.0	1270	77	0.52	26.9	9.1	1150	79	1.381	26.9	2.3	1270	76	0.40	26.9
	360	341.6	4.2	1270	77	0.73	26.9	2.8	1270	77	0.49	26.9	8.5	1160	79	1.305	26.9	2.1	1270	75	0.38	26.9
	400	373.8	3.9	1340	82	0.66	26.9	2.6	1340	81	0.44	26.9	7.8	1340	83	1.312	26.9	1.9	1340	81	0.34	26.9
	450	419.2	3.5	1340	82	0.59	26.9	2.3	1340	81	0.40	26.9	6.9	1340	83	1.169	26.9	1.7	1340	81	0.30	26.9
	500	499.9	2.9	1270	76	0.51	26.9	1.9	1270	75	0.34	26.9	5.8	1230	77	0.970	26.9	1.5	1270	75	0.26	26.9
	560	547.4	2.6	1270	76	0.46	26.9	1.8	1270	75	0.31	26.9	5.3	1250	77	0.901	26.9	1.3	1270	74	0.24	26.9
	800	747.7	1.9	1270	75	0.34	26.9	1.3	1270	74	0.23	26.9	3.9	1270	76	0.679	26.9	1.0	1270	74	0.17	26.9
900	838.5	1.7	1270	75	0.31	26.9	1.1	1270	74	0.21	26.9	3.5	1270	76	0.605	26.9	0.86	1270	73	0.16	26.9	
C0741	10C	1009	1.4	1340	81	0.25	26.9	0.95	1340	81	0.16	26.9	2.9	1340	81	0.50	26.9	0.72	1340	81	0.12	26.9
	11C	1097	1.3	1340	81	0.23	26.9	0.88	1340	81	0.15	26.9	2.6	1340	81	0.46	26.9	0.66	1340	81	0.11	26.9
	12C	1213	1.2	1340	80	0.21	26.9	0.79	1340	80	0.14	26.9	2.4	1340	80	0.42	26.9	0.60	1340	80	0.10	26.9
	14C	1396	1.0	1340	80	0.18	26.9	0.69	1340	80	0.12	26.9	2.1	1340	80	0.36	26.9	0.52	1340	80	0.091	26.9
	16C	1517	0.96	1340	80	0.17	26.9	0.63	1340	80	0.11	26.9	1.9	1340	80	0.34	26.9	0.48	1340	80	0.084	26.9
	18C	1662	0.87	1340	80	0.15	26.9	0.58	1340	80	0.10	26.9	1.7	1340	80	0.31	26.9	0.44	1340	80	0.077	26.9
	20C	1995	0.73	1340	80	0.13	26.9	0.48	1340	80	0.084	26.9	1.5	1340	80	0.25	26.9	0.36	1340	80	0.064	26.9
	22C	2186	0.66	1340	80	0.12	26.9	0.44	1340	80	0.077	26.9	1.3	1340	80	0.23	26.9	0.33	1340	80	0.058	26.9
	25C	2463	0.59	1340	80	0.10	26.9	0.39	1340	80	0.068	26.9	1.2	1340	80	0.21	26.9	0.29	1340	80	0.052	26.9
	28C	2863	0.51	1340	80	0.089	26.9	0.34	1340	80	0.059	26.9	1.0	1340	80	0.18	26.9	0.25	1340	80	0.044	26.9
	32C	3135	0.46	1340	80	0.081	26.9	0.31	1340	80	0.054	26.9	0.93	1340	80	0.16	26.9	0.23	1340	80	0.041	26.9
	36C	3559	0.41	1340	80	0.071	26.9	0.27	1340	80	0.047	26.9	0.81	1340	80	0.14	26.9	0.20	1340	80	0.036	26.9
	40C	4046	0.36	1340	80	0.063	26.9	0.24	1340	80	0.042	26.9	0.72	1340	80	0.13	26.9	0.18	1340	80	0.031	26.9
	45C	4329	0.33	1340	80	0.059	26.9	0.22	1340	80	0.039	26.9	0.67	1340	80	0.12	26.9	0.17	1340	80	0.029	26.9
	50C	4913	0.30	1340	78	0.053	26.9	0.20	1340	78	0.035	26.9	0.59	1340	78	0.11	26.9	0.15	1340	78	0.027	26.9
	56C	5585	0.26	1340	78	0.047	26.9	0.17	1340	78	0.031	26.9	0.52	1340	78	0.093	26.9	0.13	1340	78	0.023	26.9
	63C	6206	0.23	1340	78	0.042	26.9	0.15</														

SERIES C

RATINGS

Key: Pm= Input Power (kW) M2= Output Torque (Nm) i= Exact Ratio n2= Output Speed (rpm) Fra = Overhung load (kN)

			n1 = 1450					n1 = 960					n1 = 2900					n1 = 725				
	<i>h</i>	<i>i</i>	n2	M2	η (%)	Pm	Fra	n2	M2	η (%)	Pm	Fra	n2	M2	η (%)	Pm	Fra	n2	M2	η (%)	Pm	Fra
C0821	8.0	7.770	186.6	977	92	20.75	26.3	123.6	974	92	13.70	28.8	373	828	91	35.56	0.0	93.3	970	92	10.30	31.6
	11.	11.01	131.7	1320	92	19.79	27.7	87.2	1380	92	13.70	30.2	263	978	92	29.32	0.0	65.8	1370	92	10.27	34.5
	12.	12.24	118.5	1380	93	18.41	28.3	78.4	1530	92	13.66	30.8	237	1030	92	27.78	0.0	59.2	1520	92	10.25	34.2
	14.	13.61	106.5	1430	92	17.34	29.2	70.5	1670	91	13.55	31.4	213	1080	92	26.19	0.0	53.3	1680	91	10.30	33.8
	16.	15.54	93.3	1390	89	15.26	31.6	61.8	1620	89	11.77	34.3	187	1040	87	23.36	24.0	46.7	1750	88	9.71	35.0
	18.	17.60	82.4	1580	91	14.98	31.3	54.5	1830	91	11.49	33.8	165	1200	92	22.50	25.0	41.2	2020	90	9.68	35.5
	20.	19.76	73.4	1650	92	13.78	32.4	48.6	1910	91	10.68	35.0	146.8	1260	92	21.05	25.5	36.7	2100	90	8.96	36.4
	22.	22.03	65.8	1580	89	12.24	34.5	43.6	1780	88	9.23	38.1	131.6	1210	88	18.95	26.0	32.9	1880	87	7.45	41.7
	25.	24.47	59.3	1650	88	11.63	35.1	39.2	1820	88	8.50	39.4	118.5	1260	88	17.77	26.6	29.6	1920	86	6.93	41.7
	28.	27.22	53.3	1700	88	10.78	35.8	35.3	1860	87	7.90	40.7	106.5	1320	88	16.73	27.2	26.6	1960	86	6.36	41.7
	32.	31.78	45.6	1950	90	10.35	35.6	30.2	2230	89	7.93	40.2	91.3	1520	91	15.96	27.9	22.8	2430	89	6.52	41.7
	36.	35.20	41.2	1950	87	9.67	38.8	27.3	1950	86	6.48	41.7	82.4	1450	87	14.38	28.4	20.6	2050	85	5.20	41.7
	40.	39.51	36.7	1990	87	8.79	40.2	24.3	1990	86	5.89	41.7	73.4	1520	88	13.28	29.5	18.3	2090	85	4.72	41.7
	45.	43.64	33.2	2170	90	8.39	39.0	22.0	2460	89	6.37	41.7	66.5	1710	91	13.08	31.4	16.61	2650	88	5.24	41.7
	50.	49.26	29.4	2250	89	7.79	40.5	19.5	2540	88	5.89	41.7	58.9	1780	91	12.06	32.2	14.72	2730	87	4.84	41.7
	56.	54.60	26.6	1960	86	6.34	41.7	17.6	2100	84	4.60	41.7	53.1	1700	88	10.74	32.6	13.28	2210	84	3.66	41.7
	63.	63.56	22.8	2010	85	5.65	41.7	15.1	2150	84	4.05	41.7	45.6	1760	87	9.67	33.4	11.41	2270	83	3.27	41.7
	71.	69.64	20.8	2490	88	6.17	41.7	13.8	2780	87	4.61	41.7	41.6	2010	90	9.74	34.5	10.41	2970	87	3.72	41.7
	80.	76.50	19.0	2560	88	5.77	41.7	12.5	2840	87	4.29	41.7	37.9	2080	89	9.28	35.6	9.48	3030	86	3.50	41.7
	90.	87.29	16.6	2120	84	4.39	41.7	11.0	2290	83	3.18	41.7	33.2	1880	86	7.60	36.4	8.31	2410	82	2.56	41.7
	100	98.53	14.7	2160	83	4.01	41.7	9.7	2340	82	2.91	41.7	29.4	1920	86	6.88	41.7	7.36	2460	81	2.34	41.7
	112	102.4	14.2	2760	87	4.70	41.7	9.4	3040	86	3.47	41.7	28.3	2280	89	7.60	41.7	7.08	3220	85	2.81	41.7
	125	117.9	12.3	2850	86	4.27	41.7	8.1	2910	85	2.92	41.7	24.6	2380	88	6.97	41.7	6.15	2880	85	2.18	41.7
	140	139.3	10.4	2310	82	3.07	41.7	6.9	2480	81	2.21	41.7	20.8	2040	84	5.29	41.7	5.20	2590	80	1.76	41.7
	160	153.0	9.5	2350	82	2.84	41.7	6.3	2520	81	2.04	41.7	19.0	2080	84	4.91	41.7	4.74	2600	80	1.61	41.7
212	204.8	7.1	2470	81	2.26	41.7	4.7	2630	80	1.61	41.7	14.2	2180	83	3.89	41.7	3.54	2600	79	1.22	41.7	
250	235.8	6.1	2530	80	2.04	41.7	4.1	2600	79	1.40	41.7	12.3	2240	82	3.52	41.7	3.07	2600	78	1.07	41.7	
C0841	160	156	9.3	2600	81	3.12	41.7	6.2	2600	81	2.07	41.7	18.6	2600	81	6.25	41.7	4.6	2600	81	1.56	41.7
	180	177	8.2	2600	81	2.75	41.7	5.4	2600	81	1.82	41.7	16.4	2600	81	5.51	41.7	4.1	2600	81	1.38	41.7
	212	220	6.6	2600	81	2.22	41.7	4.4	2600	81	1.47	41.7	13.2	2600	81	4.43	41.7	3.3	2600	81	1.11	41.7
	250	248	5.8	2600	81	1.97	41.7	3.9	2600	81	1.30	41.7	11.7	2600	81	3.93	41.7	2.9	2600	81	0.98	41.7
	280	277	5.2	2600	81	1.76	41.7	3.5	2600	81	1.16	41.7	10.5	2600	81	3.52	41.7	2.6	2600	81	0.88	41.7
	320	312	4.6	2600	81	1.56	41.7	3.1	2600	81	1.03	41.7	9.3	2600	81	3.12	41.7	2.3	2600	81	0.78	41.7
	360	351	4.1	2600	81	1.39	41.7	2.7	2600	81	0.92	41.7	8.3	2600	81	2.78	41.7	2.1	2600	81	0.69	41.7
	400	398	3.6	2600	81	1.22	41.7	2.4	2600	81	0.81	41.7	7.3	2600	81	2.45	41.7	1.8	2600	81	0.61	41.7
	450	450	3.2	2600	81	1.08	41.7	2.1	2600	81	0.72	41.7	6.4	2600	81	2.17	41.7	1.6	2600	81	0.54	41.7
	500	475	3.1	2600	81	1.03	41.7	2.0	2600	81	0.68	41.7	6.1	2600	81	2.05	41.7	1.5	2600	81	0.51	41.7
	560	547	2.7	2600	81	0.89	41.7	1.8	2600	81	0.59	41.7	5.3	2600	81	1.78	41.7	1.3	2600	81	0.45	41.7
	630	636	2.3	2600	81	0.77	41.7	1.5	2600	81	0.51	41.7	4.6	2600	81	1.53	41.7	1.1	2600	81	0.38	41.7
	710	712	2.0	2600	81	0.68	41.7	1.3	2600	81	0.45	41.7	4.1	2600	81	1.37	41.7	1.0	2600	81	0.34	41.7
	800	759	1.9	2600	81	0.64	41.7	1.3	2600	81	0.43	41.7	3.8	2600	81	1.28	41.7	1.0	2600	81	0.32	41.7
	900	899	1.6	2600	81	0.54	41.7	1.1	2600	81	0.36	41.7	3.2	2600	81	1.08	41.7	0.81	2600	81	0.27	41.7
	10C	960	1.5	2600	81	0.51	41.7	1.0	2600	81	0.34	41.7	3.0	2600	81	1.02	41.7	0.76	2600	81	0.25	41.7
	11C	1084	1.3	2600	81	0.45	41.7	0.89	2600	81	0.30	41.7	2.7	2600	81	0.90	41.7	0.67	2600	81	0.22	41.7
	12C	1191	1.2	2600	81	0.41	41.7	0.81	2600	81	0.27	41.7	2.4	2600	81	0.82	41.7	0.61	2600	81	0.20	41.7
	14C	1405	1.0	2600	81	0.35	41.7	0.68	2600	81	0.23	41.7	2.1	2600	81	0.69	41.7	0.52	2600	81	0.17	41.7
	16C	1532	0.95	2600	80	0.32	41.7	0.63	2600	80	0.21	41.7	1.9	2600	80	0.64	41.7	0.47	2600	80	0.16	41.7
	18C	1901	0.76	2600	80	0.26	41.7	0.50	2600	80	0.17	41.7	1.5	2600	80	0.52	41.7	0.38	2600	80	0.13	41.7
	20C	2068	0.70	2600	79	0.24	41.7	0.46	2600	79	0.16	41.7	1.4	2600	79	0.48	41.7	0.35	2600	79	0.12	41.7
	22C	2242	0.65	2600	80	0.22	41.7	0.43	2600	80	0.15	41.7	1.3	2600	80	0.44	41.7	0.32	2600	80	0.11	41.7
	25C	2463	0.59	2600	79	0.20	41.7	0.39	2600	79	0.13	41.7	1.2	2600	79	0.41	41.7	0.29	2600	79	0.10	41.7
	28C	2697	0.54	2600	79	0.19	41.7	0.36	2600	79	0.12	41.7	1.1	2600	79	0.37	41.7	0.27	2600	79	0.093	41.7
32C	3305	0.44	2600	79	0.15	41.7	0.29	2600	79	0.10	41.7	0.9	2600	79	0.30	41.7	0.22	2600	79	0.076	41.7	
36C	3761	0.39	2600	80	0.13	41.7	0.26	2600	80	0.087	41.7	0.8	2600	80	0.26	41.7	0.19	2600	80	0.066	41.7	
40C	4131	0.35	2600	79	0.12	41.7	0.23	2600	79	0.080	41.7	0.7	2600	79	0.24	41.7	0.18	2600	79	0.060	41.7	
45C	4423	0.33	2600	79	0.11	41.7	0.22	2600	79	0.075	41.7	0.7	2600	79	0.23	41.7	0.16	2600	79	0.056	41.7	
50C	4929	0.29	2600	78	0.10	41.7	0.19	2600	78	0.068	41.7	0.6	2600	78	0.21	41.7	0.15	2600	78	0.051	41.7	
56C	5528	0.26	2600	78	0.092	41.7	0.17	2600	78	0.061	41.7	0.5	2600	78	0.18	41.7	0.13	2600	78	0.046	41.7	
63C	6366	0.23	2600	78	0.080	41.7	0.15	2600	78	0.053	41.7	0.5	2600	78	0.16	41.7	0.11	2600	78	0.040	41.7	
71C	6707	0.22	2310	73	0.072	41.7	0.14	2310	73	0.047	41.7	0.4	2310	73	0.14	41.7	0.11	2310	73	0.036	41.7	
80C	8262	0.18	2350	73	0.059	41.7	0.12	2350	73	0.039	41.7	0.4	2350	73	0.12	41.7	0.088	2350	73	0.030	41.7	
90C	8845	0.16	2470	72	0.059	41.7	0.11															

SERIES C

RATINGS

Key: Pm= Input Power (kW) M2= Output Torque (Nm) i= Exact Ratio n2= Output Speed (rpm) Fra = Overhung load (kN)

			n1 = 1450					n1 = 960					n1 = 2900					n1 = 725				
	<i>n</i>	<i>i</i>	n2	M2	η (%)	Pm	Fra	n2	M2	η (%)	Pm	Fra	n2	M2	η (%)	Pm	Fra	n2	M2	η (%)	Pm	Fra
C0921	8.0	7.973	181.9	2120	93	43.41	39.3	120.4	2510	93	34.03	41.8	363.7	1530	92	63.34	0.0	90.9	2800	93	28.67	42.8
	11.	10.98	132.1	2420	93	35.98	42.1	87.4	2840	93	27.96	44.8	264.1	1790	93	53.23	0.0	66.0	3160	93	23.49	45.5
	12.	12.30	117.9	2540	93	33.71	43.1	78.0	2970	93	26.10	45.9	235.8	1890	93	50.17	0.0	58.9	3290	92	22.07	46.4
	14.	13.81	105.0	2650	93	31.33	44.5	69.5	3100	92	24.53	47.4	210.0	1990	93	47.05	0.0	52.5	3430	92	20.49	47.3
	16.	16.68	86.9	2580	89	26.39	49.4	57.6	3030	89	20.52	53.2	173.9	1930	88	39.93	36.8	43.5	3360	88	17.38	53.2
	18.	17.79	81.5	2920	93	26.80	47.7	54.0	3400	92	20.88	50.8	163.0	2220	93	40.75	38.2	40.8	3750	91	17.59	53.2
	20.	19.88	72.9	3040	92	25.24	49.3	48.3	3530	92	19.40	52.5	145.9	2330	93	38.27	0.0	36.5	3890	91	16.32	53.2
	22.	22.96	63.2	2920	89	21.70	53.2	41.8	3410	88	16.97	53.2	126.3	2220	88	33.37	0.0	31.6	3760	88	14.13	53.2
	25.	25.73	56.4	3050	89	20.22	53.2	37.3	3550	88	15.76	53.2	112.7	2320	88	31.11	0.0	28.2	3910	87	13.26	53.2
	28.	28.89	50.2	3180	88	18.99	53.2	33.2	3700	88	14.63	53.2	100.4	2440	88	29.14	53.2	25.1	4070	86	12.44	53.2
	32.	31.43	46.1	3590	91	19.06	53.2	30.5	4070	90	14.46	53.2	92.3	2790	93	28.98	53.2	23.1	4200	90	11.27	53.2
	36.	37.22	39.0	3490	87	16.36	53.2	25.8	4030	86	12.66	53.2	77.9	2690	88	24.94	53.2	19.5	4410	86	10.46	53.2
	40.	41.59	34.9	3640	87	15.27	53.2	23.1	4180	86	11.75	53.2	69.7	2810	88	23.31	53.2	17.4	4560	85	9.79	53.2
	45.	44.55	32.5	4030	90	15.26	53.2	21.5	4240	89	10.75	53.2	65.1	3170	92	23.49	53.2	16.3	4370	89	8.37	53.2
	50.	49.49	29.3	4090	90	13.94	53.2	19.4	4290	89	9.79	53.2	58.6	3300	92	22.01	53.2	14.6	4410	89	7.60	53.2
	56.	57.66	25.1	4060	86	12.43	53.2	16.6	4620	85	9.48	53.2	50.3	3180	88	19.03	53.2	12.6	4990	84	7.82	53.2
	63.	65.74	22.1	4240	86	11.39	53.2	14.6	4790	84	8.72	53.2	44.1	3340	88	17.53	53.2	11.0	5160	83	7.18	53.2
	71.	69.91	20.7	4260	89	10.40	53.2	13.7	4440	88	7.25	53.2	41.5	3730	91	17.80	53.2	10.4	4550	87	5.68	53.2
	80.	77.18	18.8	4300	89	9.50	53.2	12.4	4480	88	6.63	53.2	37.6	3850	91	16.65	53.2	9.4	4590	87	5.19	53.2
	90.	93.18	15.6	4710	84	9.14	53.2	10.3	5240	83	6.81	53.2	31.1	3780	87	14.16	53.2	7.8	5580	82	5.54	53.2
	100	103.5	14.0	4850	84	8.47	53.2	9.3	5380	82	6.37	53.2	28.0	3920	86	13.37	53.2	7.0	5580	81	5.05	53.2
	112	106.2	13.7	4440	88	7.213	53.2	9.0	4610	87	5.02	53.2	27.3	4120	89	13.24	53.2	6.8	4710	86	3.92	53.2
	125	119.4	12.1	4490	87	6.56	53.2	8.0	4650	86	4.55	53.2	24.3	4180	89	11.94	53.2	6.1	4750	86	3.51	53.2
	140	146.2	9.9	5290	82	6.70	53.2	6.6	5580	81	4.74	53.2	19.8	4380	85	10.70	53.2	5.0	5580	80	3.62	53.2
	160	161.4	9.0	5420	82	6.22	53.2	5.9	5580	80	4.34	53.2	18.0	4520	84	10.12	53.2	4.5	5580	80	3.28	53.2
212	222.1	6.5	5580	80	4.77	53.2	4.3	5580	79	3.20	53.2	13.1	4940	83	8.14	53.2	3.3	5580	78	2.45	53.2	
250	249.7	5.8	5580	80	4.24	53.2	3.8	5580	79	2.84	53.2	11.6	5090	82	7.55	53.2	2.9	5580	77	2.20	53.2	
C0941	160	160	9.1	4800	82	5.55	53.2	6.0	4800	82	3.68	53.2	18.1	4800	82	11.11	53.2	4.5	4800	82	2.78	53.2
	180	177	8.2	4850	82	5.07	53.2	5.4	4850	82	3.36	53.2	16.4	4850	82	10.15	53.2	4.1	4850	82	2.54	53.2
	212	225	6.4	4800	82	3.95	53.2	4.3	4800	82	2.62	53.2	12.9	4800	82	7.90	53.2	3.2	4800	82	1.98	53.2
	250	249	5.8	4850	82	3.61	53.2	3.9	4850	82	2.39	53.2	11.6	4850	82	7.21	53.2	2.9	4850	82	1.80	53.2
	280	282	5.1	4800	82	3.15	53.2	3.4	4800	82	2.09	53.2	10.3	4800	82	6.30	53.2	2.6	4800	82	1.58	53.2
	320	314	4.6	4850	82	2.86	53.2	3.1	4850	82	1.89	53.2	9.2	4850	82	5.72	53.2	2.3	4850	82	1.43	53.2
	360	359	4.0	4800	82	2.48	53.2	2.7	4800	82	1.64	53.2	8.1	4800	82	4.95	53.2	2.0	4800	82	1.24	53.2
	400	407	3.6	4800	82	2.18	53.2	2.4	4800	82	1.45	53.2	7.1	4800	82	4.37	53.2	1.8	4800	82	1.09	53.2
	450	452	3.2	4850	82	1.99	53.2	2.1	4850	82	1.32	53.2	6.4	4850	82	3.97	53.2	1.6	4850	82	0.99	53.2
	500	485	3.0	4800	82	1.83	53.2	2.0	4800	82	1.21	53.2	6.0	4800	82	3.67	53.2	1.5	4800	82	0.92	53.2
	560	558	2.6	4800	82	1.59	53.2	1.7	4800	82	1.05	53.2	5.2	4800	82	3.19	53.2	1.3	4800	82	0.80	53.2
	630	649	2.2	4800	82	1.37	53.2	1.5	4800	82	0.91	53.2	4.5	4800	82	2.74	53.2	1.1	4800	82	0.68	53.2
	710	727	2.0	4800	82	1.22	53.2	1.3	4800	82	0.81	53.2	4.0	4800	82	2.45	53.2	1.0	4800	82	0.61	53.2
	800	774	1.9	4800	82	1.15	53.2	1.2	4800	82	0.76	53.2	3.7	4800	82	2.30	53.2	0.94	4800	82	0.57	53.2
	900	918	1.6	4800	82	0.97	53.2	1.0	4800	82	0.64	53.2	3.2	4800	82	1.94	53.2	0.79	4800	82	0.48	53.2
	10C	980	1.5	4800	82	0.91	53.2	1.0	4800	82	0.60	53.2	3.0	4800	82	1.81	53.2	0.74	4800	82	0.45	53.2
	11C	1089	1.3	4800	80	0.84	53.2	0.88	4800	80	0.55	53.2	2.7	4800	80	1.67	53.2	0.67	4800	80	0.42	53.2
	12C	1216	1.2	4800	82	0.73	53.2	0.79	4800	82	0.48	53.2	2.4	4800	82	1.46	53.2	0.60	4800	82	0.37	53.2
	14C	1434	1.0	4800	82	0.62	53.2	0.67	4800	82	0.41	53.2	2.0	4800	82	1.24	53.2	0.51	4800	82	0.31	53.2
	16C	1538	0.94	5000	81	0.61	53.2	0.62	5000	81	0.40	53.2	1.9	5000	81	1.22	53.2	0.47	5000	81	0.30	53.2
	18C	1908	0.76	5000	81	0.49	53.2	0.50	5000	81	0.33	53.2	1.5	5000	81	0.98	53.2	0.38	5000	81	0.25	53.2
	20C	2107	0.69	5000	81	0.44	53.2	0.46	5000	81	0.29	53.2	1.4	5000	81	0.89	53.2	0.34	5000	81	0.22	53.2
	22C	2250	0.64	5000	81	0.42	53.2	0.43	5000	81	0.28	53.2	1.3	5000	81	0.83	53.2	0.32	5000	81	0.21	53.2
	25C	2484	0.58	5000	81	0.38	53.2	0.39	5000	81	0.25	53.2	1.2	5000	81	0.75	53.2	0.29	5000	81	0.19	53.2
	28C	2720	0.53	5000	81	0.34	53.2	0.35	5000	81	0.23	53.2	1.1	5000	81	0.69	53.2	0.27	5000	81	0.17	53.2
	32C	3334	0.43	5000	81	0.28	53.2	0.29	5000	81	0.19	53.2	0.87	5000	81	0.56	53.2	0.22	5000	81	0.14	53.2
	36C	3775	0.38	5000	81	0.25	53.2	0.25	5000	81	0.16	53.2	0.77	5000	81	0.50	53.2	0.19	5000	81	0.12	53.2
	40C	4167	0.35	5000	81	0.22	53.2	0.23	5000	81	0.15	53.2	0.70	5000	81	0.45	53.2	0.17	5000	81	0.11	53.2
	45C	4586	0.32	5000	80	0.21	53.2	0.21	5000	80	0.14	53.2	0.63	5000	80	0.41	53.2	0.16	5000	80	0.10	53.2
	50C	5112	0.28	5000	80	0.19	53.2	0.19	5000	80	0.12	53.2	0.57	5000	80	0.37	53.2	0.14	5000	80	0.093	53.2
	56C	5733	0.25	5000	80	0.17	53.2	0.17	5000	80	0.11	53.2	0.51	5000	80	0.33	53.2	0.13	5000	80	0.083	53.2
	63C	6447	0.22	5000	79	0.15	53.2	0.15	5000	79	0.10	53.2	0.45	5000	79	0.30	53.2	0.11	5000	79	0.075	53.2
71C	7041	0.21	5580	75	0.16	53.2	0.14	5580	75	0.11	53.2	0.41	5580	75	0.32	53.2	0.10	5580	75	0.080	53.2	
80C	7897	0.18	5580	75	0.14	53.2	0.12	5580	75	0.095	53.2	0.37	5580	75	0.29	53.2	0.092	5580	75	0.072	53.2	
90C	8718	0.17	5580	75	0																	

SERIES C

RATINGS

Key: Pm= Input Power (kW) M2= Output Torque (Nm) i= Exact Ratio n2= Output Speed (rpm) Fra = Overhung load (kN)

			n1 = 1450					n1 = 960					n1 = 2900					n1 = 725				
	<i>in</i>	<i>i</i>	n2	M2	η (%)	Pm	Fra	n2	M2	η (%)	Pm	Fra	n2	M2	η (%)	Pm	Fra	n2	M2	η (%)	Pm	Fra
C1021	8.0	7.951	182.4	3730	94	75.77	47.8	120.7	3840	94	51.65	52.2	364.7	2690	93	110.47	0.0	91.2	3830	94	38.90	55.0
	11.	11.11	130.5	4300	94	62.52	51.2	86.4	5060	93	49.23	54.2	261.0	3170	94	92.17	0.0	65.3	5330	93	39.16	56.0
	12.	12.08	120.0	4450	94	59.50	52.1	79.5	5220	93	46.71	55.3	240.1	3290	93	88.93	0.0	60.0	5780	93	39.06	58.0
	14.	13.72	105.7	4680	94	55.10	53.9	70.0	5480	93	43.17	57.2	211.4	3490	93	83.06	0.0	52.8	6070	93	36.11	62.0
	16.	16.63	87.2	4730	91	47.46	60.1	57.7	5530	90	37.14	64.3	174.4	3520	89	72.22	47.8	43.6	5900	90	29.93	66.0
	18.	17.87	81.1	5180	93	47.32	57.8	53.7	6030	93	36.47	61.3	162.3	3930	94	71.05	48.0	40.6	6670	92	30.80	65.0
	20.	19.29	75.2	5330	93	45.11	59.4	49.8	6200	93	34.74	63.0	150.3	4060	94	67.99	50.0	37.6	6850	92	29.30	68.0
	22.	23.23	62.4	5390	90	39.14	65.4	41.3	5970	90	28.70	70.9	124.8	4080	90	59.26	52.0	31.2	6330	89	23.24	78.0
	25.	25.27	57.4	5540	90	36.99	66.3	38.0	6080	89	27.18	72.8	114.8	4230	90	56.48	52.5	28.7	6440	89	21.74	82.0
	28.	28.70	50.5	5710	90	33.56	67.9	33.4	6240	89	24.56	75.7	101.0	4460	90	52.43	53.0	25.3	6590	88	19.81	83.0
	32.	31.85	45.5	6400	92	33.16	63.9	30.1	7370	91	25.56	71.3	91.1	4960	93	50.85	53.5	22.8	8050	91	21.09	80.0
	36.	37.38	38.8	6060	90	27.35	72.3	25.7	6570	88	20.08	82.3	77.6	4950	90	44.68	55.3	19.4	6900	88	15.92	85.2
	40.	40.36	35.9	6150	89	26.00	74.0	23.8	6660	88	18.85	84.3	71.9	5100	90	42.64	56.7	18.0	6990	87	15.11	87.2
	45.	43.65	33.2	7140	91	27.29	69.4	22.0	8130	90	20.80	78.3	66.4	5580	93	41.74	58.0	16.6	8470	90	16.37	87.2
	50.	48.51	29.9	7390	91	25.42	71.5	19.8	8320	90	19.16	80.9	59.8	5800	92	39.46	60.0	14.9	8530	90	14.83	87.2
	56.	58.85	24.6	6620	88	19.41	83.4	16.3	7090	87	13.92	87.2	49.3	5740	89	33.28	62.0	12.3	7460	86	11.19	87.2
	63.	66.62	21.8	6770	88	17.53	86.8	14.4	7230	87	12.54	87.2	43.5	5910	89	30.27	63.0	10.9	7640	85	10.24	87.2
	71.	69.18	21.0	8250	90	20.12	79.4	13.9	8630	89	14.09	87.2	41.9	6590	92	31.44	64.0	10.5	8800	89	10.85	87.2
	80.	79.71	18.2	8390	90	17.76	83.3	12.0	8740	89	12.38	87.2	36.4	6920	91	28.97	67.4	9.1	8810	88	9.53	87.2
	90.	91.32	15.9	7120	86	13.77	87.2	10.5	7690	85	9.96	87.2	31.8	6310	89	23.58	69.5	7.9	8090	84	8.01	87.2
	100	101.5	14.3	7240	86	12.59	87.2	9.5	7840	85	9.13	87.2	28.6	6440	88	21.89	75.5	7.1	8230	84	7.33	87.2
	112	107.8	13.5	8650	89	13.69	87.2	8.9	8700	88	9.22	87.2	26.9	7650	91	23.68	77.0	6.7	8640	87	6.99	87.2
	125	115.8	12.5	7980	89	11.76	87.2	8.3	7900	87	7.88	87.2	25.0	7820	90	22.79	79.4	6.3	7840	87	5.91	87.2
	140	144.7	10.0	7760	85	9.58	87.2	6.6	8330	83	6.97	87.2	20.0	6860	87	16.55	81.0	5.0	8690	82	5.56	87.2
	160	166.7	8.7	7960	84	8.63	87.2	5.8	8520	83	6.19	87.2	17.4	7020	86	14.87	84.5	4.3	8830	82	4.90	87.2
212	225.5	6.4	8370	83	6.79	87.2	4.3	8830	82	4.80	87.2	12.9	7400	85	11.72	87.2	3.2	8810	81	3.66	87.2	
250	242.3	6.0	8470	83	6.39	87.2	4.0	8820	81	4.52	87.2	12.0	7510	85	11.07	87.2	3.0	8800	80	3.45	87.2	
C1041	160	160	9.1	8330	83	9.52	87.2	6.0	8330	83	6.31	87.2	18.1	8330	83	19.05	87.2	4.5	8330	83	4.76	87.2
	180	177	8.2	8150	83	8.42	87.2	5.4	8150	83	5.58	87.2	16.4	8150	83	16.85	87.2	4.1	8150	83	4.21	87.2
	212	225	6.4	8330	83	6.77	87.2	4.3	8330	83	4.48	87.2	12.9	8330	83	13.55	87.2	3.2	8330	83	3.39	87.2
	250	249	5.8	8150	83	5.99	87.2	3.9	8150	83	3.96	87.2	11.6	8150	83	11.97	87.2	2.9	8150	83	2.99	87.2
	280	282	5.1	8330	83	5.40	87.2	3.4	8330	83	3.58	87.2	10.3	8330	83	10.81	87.2	2.6	8330	83	2.70	87.2
	320	314	4.6	8150	83	4.75	87.2	3.1	8150	83	3.14	87.2	9.2	8150	83	9.50	87.2	2.3	8150	83	2.37	87.2
	360	359	4.0	8330	83	4.24	87.2	2.7	8330	83	2.81	87.2	8.1	8330	83	8.49	87.2	2.0	8330	83	2.12	87.2
	400	407	3.6	8330	83	3.74	87.2	2.4	8330	83	2.48	87.2	7.1	8330	83	7.49	87.2	1.8	8330	83	1.87	87.2
	450	452	3.2	8150	83	3.30	87.2	2.1	8150	83	2.18	87.2	6.4	8150	83	6.60	87.2	1.6	8150	83	1.65	87.2
	500	485	3.0	8330	83	3.14	87.2	2.0	8330	83	2.08	87.2	6.0	8330	83	6.28	87.2	1.5	8330	83	1.57	87.2
	560	558	2.6	8330	83	2.73	87.2	1.7	8330	83	1.81	87.2	5.2	8330	83	5.46	87.2	1.3	8330	83	1.37	87.2
	630	649	2.2	8330	83	2.35	87.2	1.5	8330	83	1.55	87.2	4.5	8330	83	4.70	87.2	1.1	8330	83	1.17	87.2
	710	727	2.0	8330	83	2.10	87.2	1.3	8330	83	1.39	87.2	4.0	8330	83	4.19	87.2	1.0	8330	83	1.05	87.2
	800	774	1.9	8330	83	1.97	87.2	1.2	8330	83	1.30	87.2	3.7	8330	83	3.94	87.2	0.94	8330	83	0.98	87.2
	900	918	1.6	8330	83	1.66	87.2	1.0	8330	83	1.10	87.2	3.2	8330	83	3.32	87.2	0.79	8330	83	0.83	87.2
	10C	980	1.5	8330	83	1.55	87.2	0.98	8330	83	1.03	87.2	3.0	8330	83	3.11	87.2	0.74	8330	83	0.78	87.2
	11C	1089	1.3	8150	83	1.37	87.2	0.88	8150	83	0.91	87.2	2.7	8150	83	2.74	87.2	0.67	8150	83	0.68	87.2
	12C	1216	1.2	8330	83	1.25	87.2	0.79	8330	83	0.83	87.2	2.4	8330	83	2.51	87.2	0.60	8330	83	0.63	87.2
	14C	1434	1.0	8330	83	1.06	87.2	0.67	8330	83	0.70	87.2	2.0	8330	83	2.13	87.2	0.51	8330	83	0.53	87.2
	16C	1538	0.94	8420	82	1.01	87.2	0.62	8420	82	0.67	87.2	1.9	8420	82	2.03	87.2	0.47	8420	82	0.51	87.2
	18C	1908	0.76	8420	82	0.82	87.2	0.50	8420	82	0.54	87.2	1.5	8420	82	1.63	87.2	0.38	8420	82	0.41	87.2
	20C	2107	0.69	8440	82	0.74	87.2	0.46	8440	82	0.49	87.2	1.4	8440	82	1.48	87.2	0.34	8440	82	0.37	87.2
	22C	2250	0.64	8420	82	0.69	87.2	0.43	8420	82	0.46	87.2	1.3	8420	82	1.39	87.2	0.32	8420	82	0.35	87.2
	25C	2484	0.58	8440	82	0.63	87.2	0.39	8440	82	0.42	87.2	1.2	8440	82	1.26	87.2	0.29	8440	82	0.31	87.2
	28C	2720	0.53	8440	82	0.57	87.2	0.35	8440	82	0.38	87.2	1.1	8440	82	1.15	87.2	0.27	8440	82	0.29	87.2
	32C	3334	0.43	8440	82	0.47	87.2	0.29	8440	82	0.31	87.2	0.87	8440	82	0.94	87.2	0.22	8440	82	0.23	87.2
	36C	3775	0.38	8420	82	0.41	87.2	0.25	8420	82	0.27	87.2	0.77	8420	82	0.83	87.2	0.19	8420	82	0.21	87.2
	40C	4167	0.35	8440	82	0.38	87.2	0.23	8440	82	0.25	87.2	0.70	8440	82	0.75	87.2	0.17	8440	82	0.19	87.2
	45C	4586	0.32	8650	81	0.35	87.2	0.21	8650	81	0.23	87.2	0.63	8650	81	0.71	87.2	0.16	8650	81	0.18	87.2
	50C	5112	0.28	8650	81	0.32	87.2	0.19	8650	81	0.21	87.2	0.57	8650	81	0.63	87.2	0.14	8650	81	0.16	87.2
	56C	5733	0.25	8650	81	0.28	87.2	0.17	8650	81	0.19	87.2	0.51	8650	81	0.57	87.2	0.13	8650	81	0.14	87.2
	63C	6447	0.22	7980	81	0.23	87.2	0.15	7980	81	0.15	87.2	0.45	7980	81	0.46	87.2	0.11	7980	81	0.12	87.2
71C	7041	0.21	8700	77	0.24	87.2	0.14	8700	77	0.16	87.2	0.41	8700	77	0.49	87.2	0.10	8700	77	0.12	87.2	
80C	7897	0.18	8700	77	0.22	87.2	0.12	8700	77	0.14	87.2	0.37	8700	77	0.43	87.2	0.092	8700	77	0.11	87.2	
90C	8718	0.17</																				

SERIES C

DIMENSIONS

DOUBLE REDUCTION

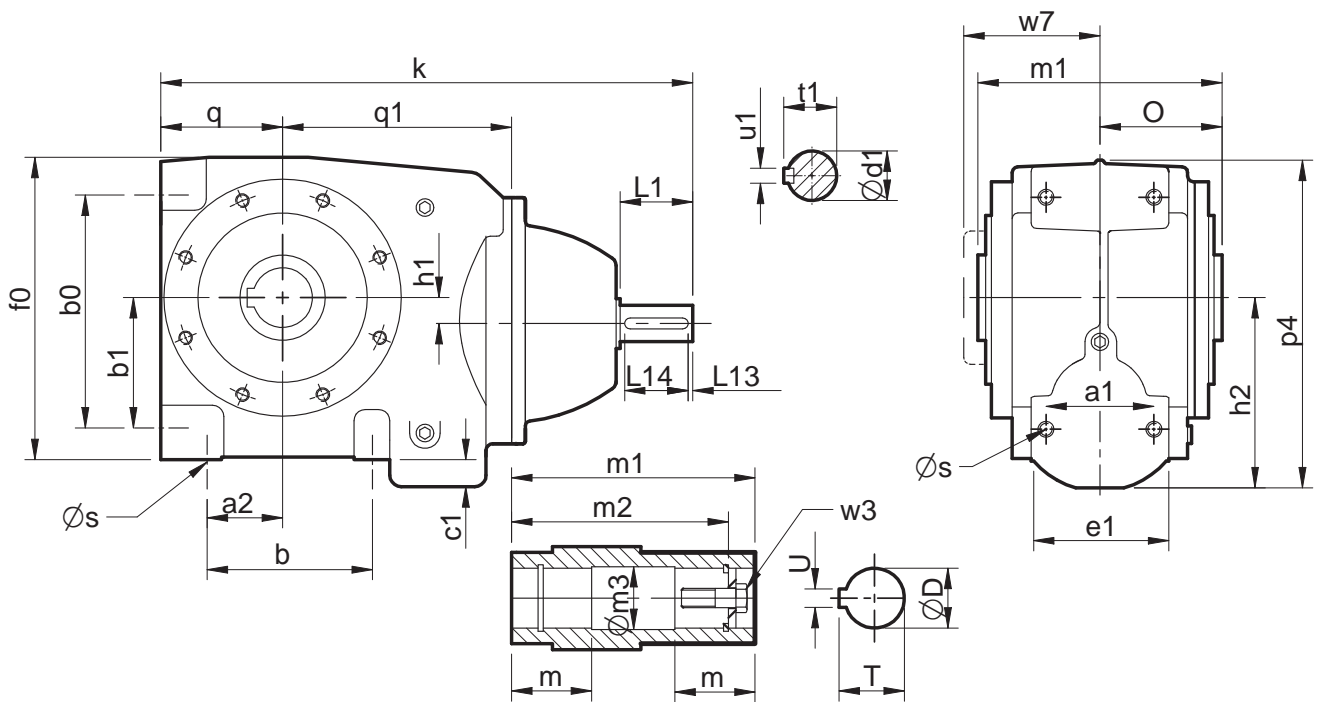

Size	a1	a2	b	b0	b1	c1	e1	f0	h1	h2	o
C0321	54	35	63	80	40	9	70	139	5.3	79.5	62
C0421	56	35	80	118	65	7	80	158	15	93	65
C0521	68	45	100	142	77	16	86	177	13	112	70
C0621	80	56	122	172	96	20	102	218	17	139.5	90

Size	p4	q	q1	s	w7	k
C0321	148	54	109	M8 x1.25 x 15	70	274
C0421	168	64	119	M10 x1.5 x 20	74.5	294
C0521	200	68	134	M10 x1.5 x 18	79	313
C0621	243	90	169	M12 x1.75 x 20	101	370

Size	d1	L1	L13	L14	t1	u1	D	m	m1	m2	m3	T	U	w3
C0321	16 k6	40	4	32	18	5	20	52	124	104	20.2	22.9	6	M6x1.0 x 40
C0421	16 k6	40	4	32	18	5	30	54	130	122	30.2	33.5	8	M10x1.5 x 50
C0521	16 k6	40	4	32	18	5	35	56	140	127	35.3	38.5	10	M12x1.75 x 55
C0621	19 k6	40	4	32	21.5	6	45	70	180	156	45.3	49	14	M16x2.0 x 70

SERIES C

DIMENSIONS

DOUBLE REDUCTION

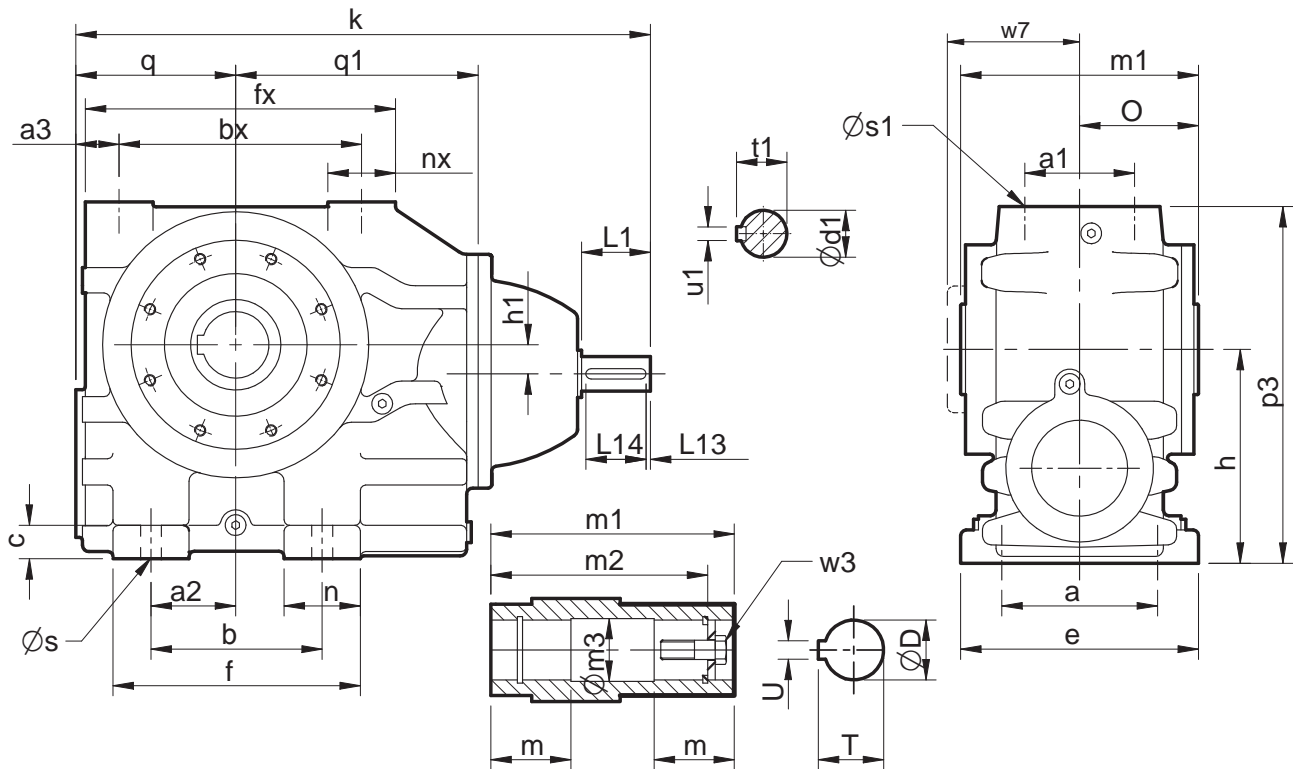

Size	a	a1	a	a3	b2	bx	c	e	f	fx	h	h1	n	nx	o
C0721	150	100	75	35,5	135	215	28	185	202	280	180	26	67	63	109
C0821	200	120	92	43	180	250	35	250	260	326	225	28	80	71	125
C0921	250	135	115	50	235	290	40	305	320	380	280	40	85	85	150
C1021	300	150	170	62,5	310	345	45	360	420	460	335	65	110	107	175

Size	p4	q	q1	s	s1	w7	k
C0721	302	143	220	18	M20 x 2,5 x 34	125	478
C0821	375	168	255	22	M20 x 2,5 x 34	143	583
C0921	457	195	300	26	M24 x 3,0 x 45	169	690
C1021	565	235	355	26	M24 x 3,0 x 45	198	823

Size	d1	L1	L13	L14	t1	u1	D	m	m1	m2	m3	T	U	w3
C0721	24 k6	50	5	40	27	8	60	79	218	188	60,5	64,6	18	M20 x 2,5 x 80
C0821	28 k6	60	5	50	31	8	70	90	250	220	70,5	75,1	20	M20 x 2,5 x 80
C0921	38 k6	80	5	70	41	10	90	107,5	300	265	90,5	95,6	25	M24 x 3,0 x 110
C1021	42 k6	110	10	70	45	12	100	132,5	350	313	100,5	106,6	28	M24 x 3,0 x 110

SERIES C

DIMENSIONS

TRIPLE REDUCTION

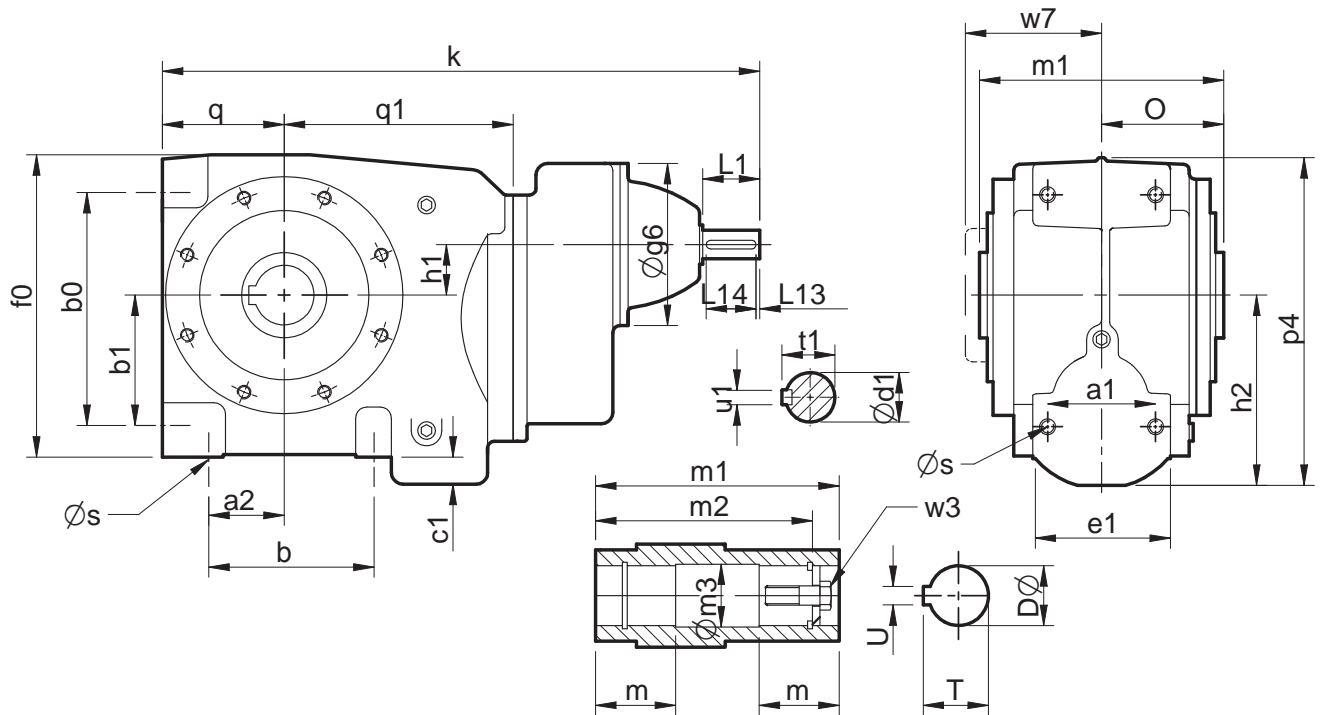

Size	a1	a2	b	b0	b1	c1	e1	f0	h1	h2	k	o
C0331	54	35	63	80	40	9	70	139	30.75	79.5	330	62
C0431	56	35	80	118	65	7	80	158	21.2	93	350	65
C0531	68	46	100	14	277	16	86	177	23	11	369	70
C0631	80	56	122	172	96	20	102	218	30	139.5	436	90

Size	p4	q	q1	s	w7
C0331	148	54	109	M8 x 1.25 x 15	70
C0431	168	64	119	M10 x 1.5 x 18	74.5
C0531	200	68	134	M10 x 1.5 x 18	79
C0631	243	90	169	M12 x 1.75 x 20	101

Size	d1	L1	L13	L14	t1	u1	D	m	m1	m2	m3	T	U	w3
C0321	16 k6	40	4	32	18	5	20	52	124	104	20.2	22.9	6	M6 x 1.0 x 40
C0421	16 k6	40	4	32	18	5	30	54	130	122	30.2	33.5	8	M10 x 1.5 x 50
C0521	16 k6	40	4	32	18	5	35	56	140	127	35.3	38.5	10	M12 x 1.75 x 55
C0621	19 k6	40	4	32	21.5	6	45	70	180	156	45.3	49	14	M16 x 2.0 x 70

SERIES C

DIMENSIONS

TRIPLE REDUCTION

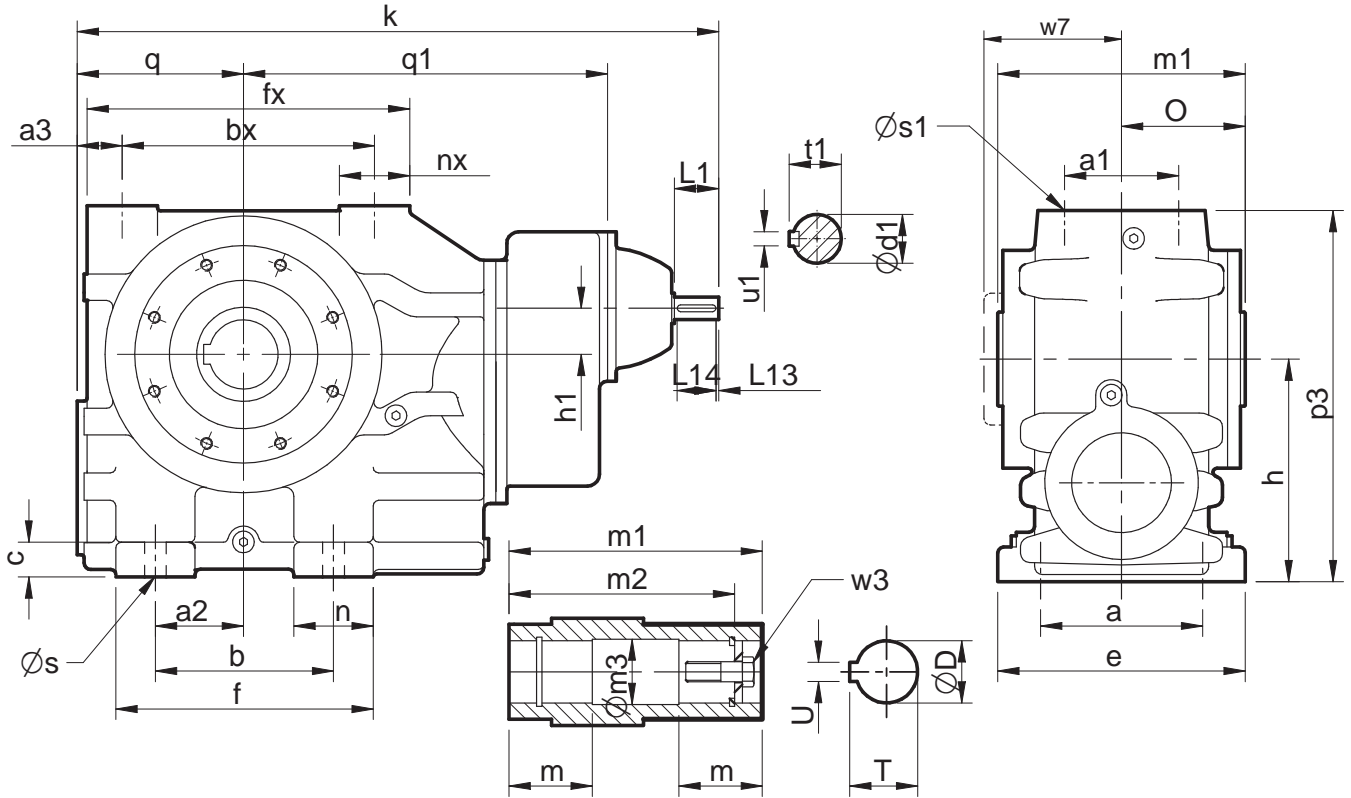

Size	a	a1	a2	a3	b	bx	c	e	f	fx	h	h1	k	n	nx	o	p3	q	q1
C0731	150	100	75	35.5	135	215	28	185	202	280	180	34	560	67	63	109	302	143	220

Size	p3	q	q1	s	s1	w7	g6
C0731	302	143	220	18	M20 x 2.5 x34	125	212

Size	d1	L1	L13	L14	t	u1	D	m	m1	m2	m3	T	U	w3
C0731	24 k6	50	5	40	27	8	60	79	218	188	60.5	64.6	18	M20 x 2.5 x 80

SERIES C

DIMENSIONS

QUADRUPLE REDUCTION

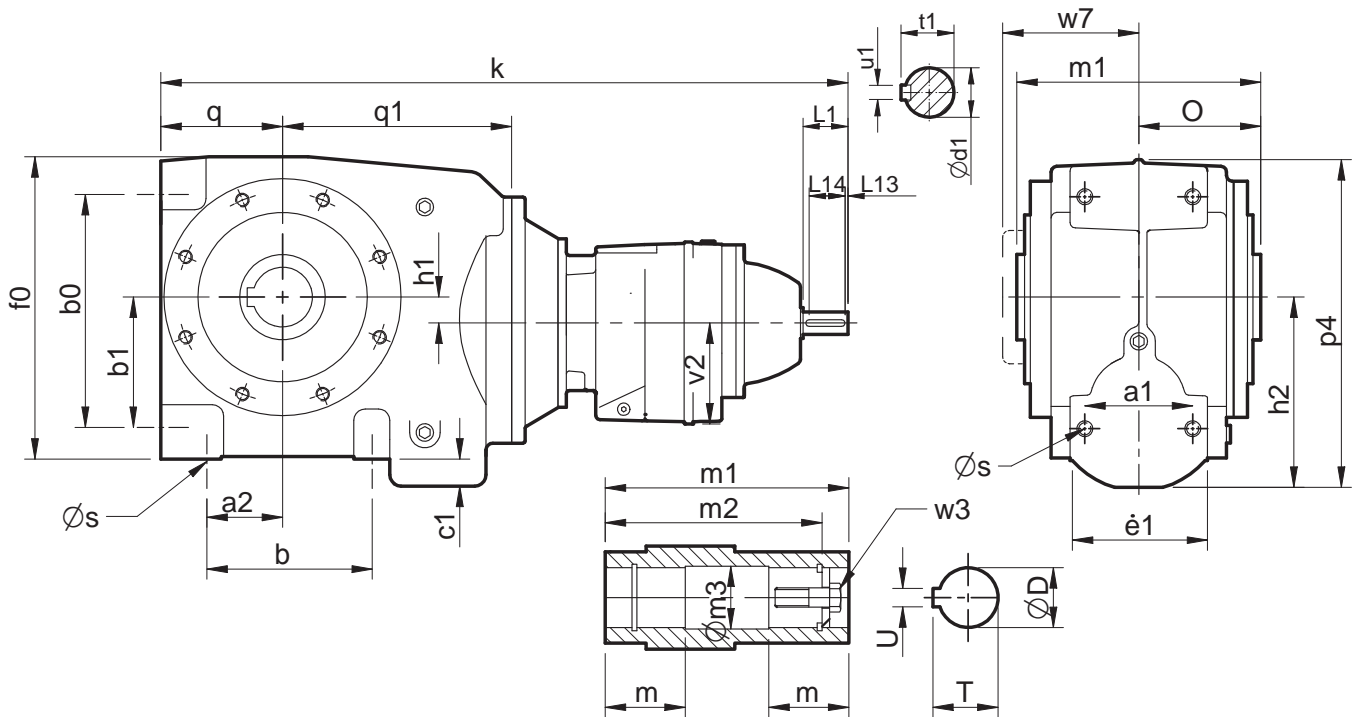

Size	a1	a2	b	b0	b1	c1	e1	f0	h1	h2	o
C0341	54	35	63	80	40	9	70	139	5.3	79.5	62
C0441	56	35	80	118	65	7	80	158	15	93	65
C0541	68	45	100	142	77	16	86	177	13	112	70
C0641	80	56	122	172	96	20	102	218	17	139.5	90

Size	p4	q	q1	s	v2	w7	k
C0341	148	54	109	M8 x1.25 x 15	76	70	460
C0441	168	64	119	M10 x1.5 x 20	76	74.5	480
C0541	200	68	134	M10 x1.5 x 18	76	79	499
C0641	243	90	169	M12 x1.75 x 20	91	101	572

Size	d1	L1	L13	L14	t1	u1	D	m	m1	m2	m3	T	U	w3
C0341	16 k6	40	4	32	18	5	20	52	124	104	20.2	22.9	6	M6 x1.0 x 40
C0441	16 k6	40	4	32	18	5	30	54	130	122	30.2	33.5	8	M10 x1.5 x 50
C0541	16 k6	40	4	32	18	5	35	56	140	127	35.3	38.5	10	M12 x1.75 x 55
C0641	16 k6	40	4	32	18	5	45	70	180	156	45.3	49	14	M16 x2.0 x 70

SERIES C

DIMENSIONS

QUADRUPLE REDUCTION

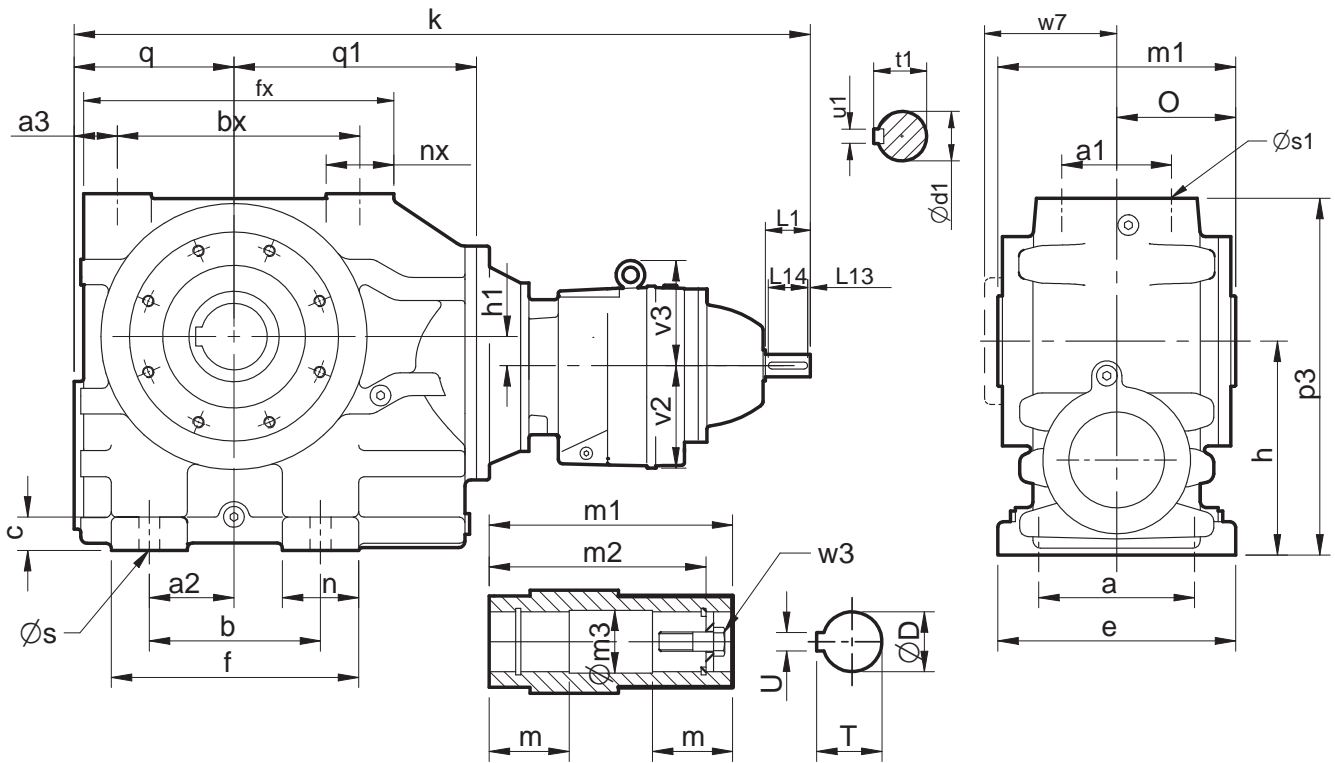

Size	a	a1	a2	a3	b	bx	c	e	f	fx	h	h1	n	nx	o
C0741	150	100	75	35.5	135	215	28	185	202	280	180	26	67	63	109
C0841	200	120	92	43	180	250	35	250	260	326	225	28	80	71	125
C0941	250	135	115	50	235	290	40	305	320	380	280	40	85	85	150
C1041	300	150	170	62.5	310	345	45	360	420	460	335	65	110	107	175

Size	p3	q	q1	s	s1	v2	v3	w7	k
C0741	302	143	220	18	M20 x 2.5 x 34	91	-	125	677
C0841	375	168	255	22	M20 x 2.5 x 34	115	-	143	779
C0941	457	195	300	26	M24 x 3.0 x 45	115	-	169	862
C1041	565	235	355	26	M24 x 3.0 x 45	140	155	198	997

Size	d1	L1	L13	L14	t1	u1	D	m	m1	m2	m3	T	U	w3
C0741	16 k6	40	4	32	18	5	60	79	218	188	60.5	64.6	18	M20 x 2.5 x 80
C0841	19 k6	40	4	32	21.5	6	70	90	250	220	70.5	75.1	20	M20 x 2.5 x 80
C0941	19 k6	40	4	32	21.5	6	90	107.5	300	265	90.5	95.6	25	M24 x 3.0 x 110
C1041	24 k6	50	5	40	27	8	100	132.5	350	313	100.5	106.6	28	M24 x 3.0 x 110

SERIES C

DIMENSIONS - FEET

C 0 2 B R

STANDARD UNIT WITH BASE MOUNTED FEET

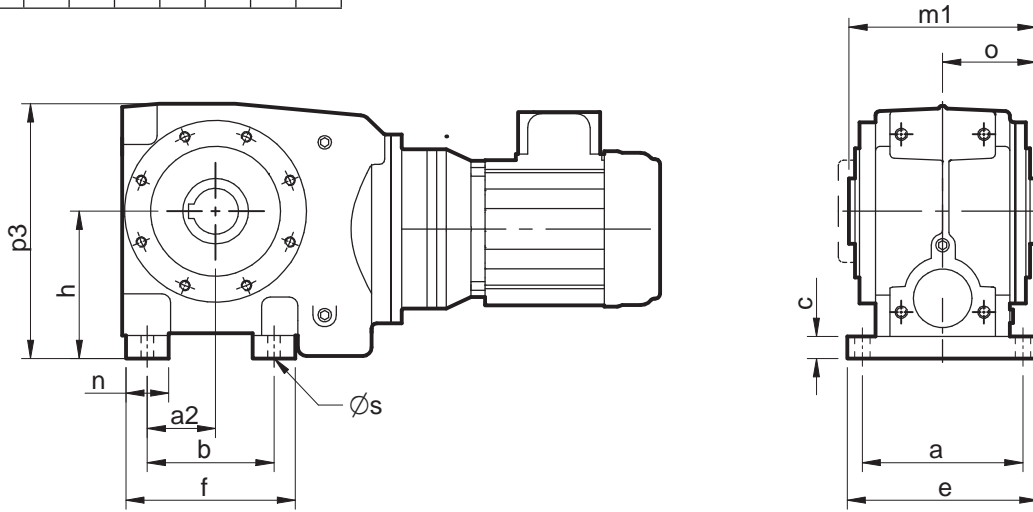

C 0 2 E R

STANDARD UNIT WITH END MOUNTED FEET

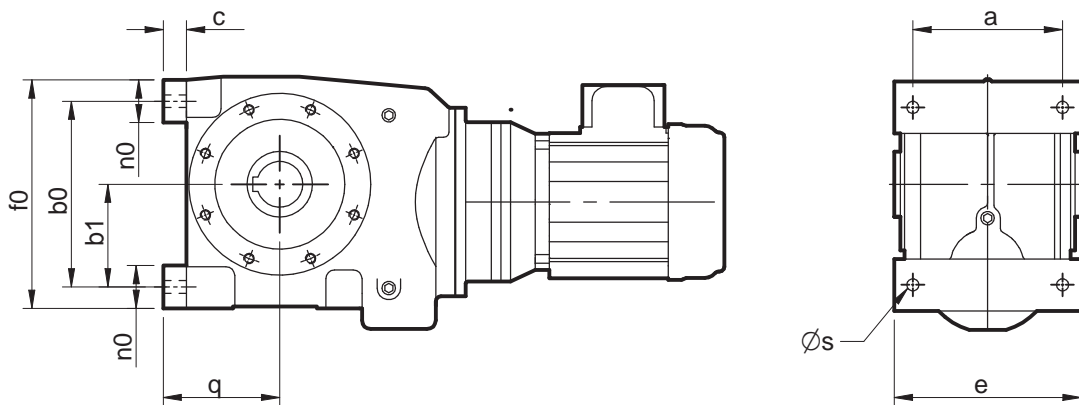

Size	a	b	b0	b1	c	e	f	f0	h	n	n0	p3	q	q2	s
C03	90	63	80	40	9	110	88	105	80	25	25	148	63	35	9
C04	100	80	118	65	14	124	115	153	100	35	35	175	78	35	11
C05	110	100	142	77	16	136	140	182	112	40	40	200	84	45	11
C06	130	130	180	100	20	160	172	222	140	50	50	243	110	60	14

SERIES C

DIMENSIONS - FEET

C **E R** **STANDARD UNIT WITH END MOUNTED FEET**

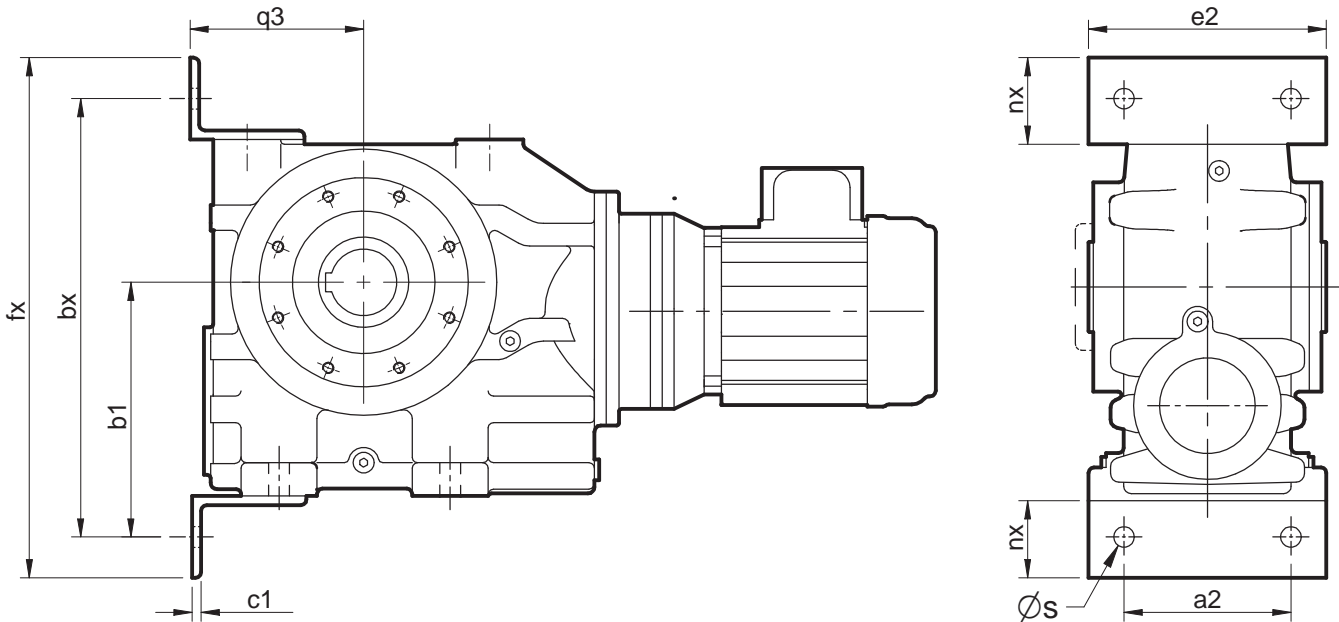

Size	a2	bx	b1	c1	e2	fx	nx	q3	s
C07	170	392	225	12	220	452	75	162	22
C08	200	465	270	12	250	525	75	187	22
C09	250	557	330	15	305	637	90	220	26
C10	300	665	385	15	360	745	90	260	26

C **R R** **STANDARD UNIT WITH TOP MOUNTED FEET**

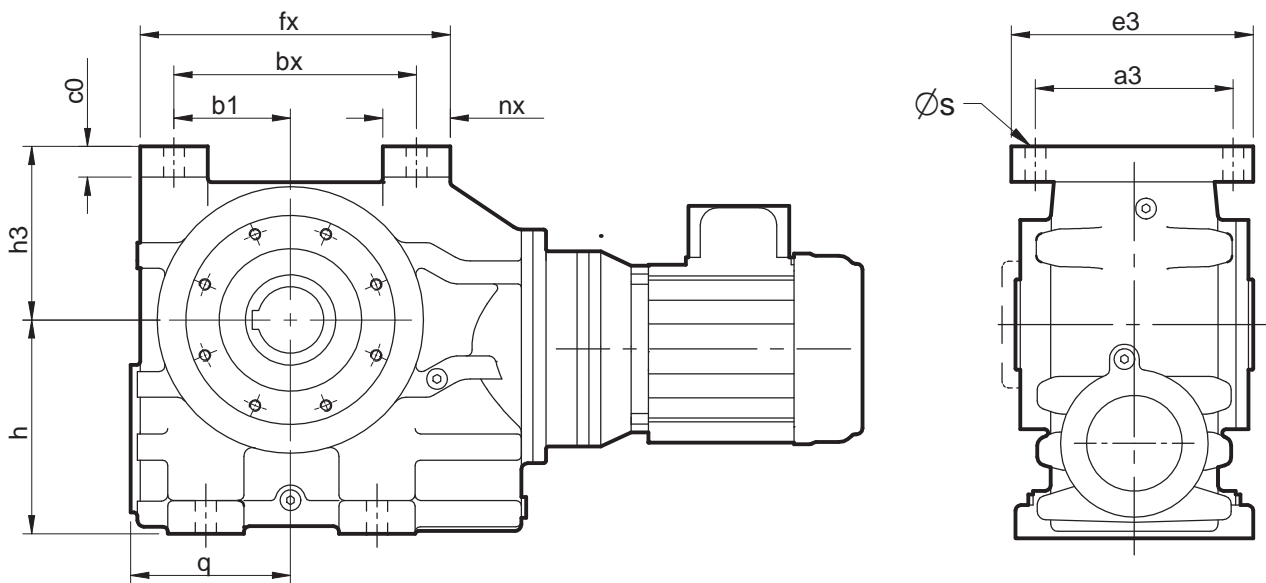

Size	a3	b1	bx	co	e3	fx	h	h3	nx	q	s
C07	205	107.5	215	28	256	278	180	150	63	143	24
C08	225	125	250	30	280	320	225	180	70	168	24
C09	240	145	290	35	300	370	280	212	80	195	28
C10	265	172.5	345	35	330	445	335	265	100	235	28

SERIES C

THERMAL POWER RATING

Thermal Ratings kW

Thermal ratings are a measure of the units ability to dissipate heat, if they are exceeded the lubricant may break down resulting in premature gear failure.

The ratings listed below are true for horizontal mounting position 1 running continuously with an ambient temperature equal to 20°C. For other mounting positions, ambients and units operating intermittently multiply thermal power ratings by factors Ft, Fp and Fd as appropriate.

Table 1 Thermal Power (kW)

Overall ratios	Input rpm	C03	C04	C05	C06	C07	C08	C09	C10
8 - 14	2900	2.80	3.85	4.69	5.1	Consult our Application engineers			
	1750	1.98	3.26	4.85	5.27				
	1450	1.73	2.85	4.41	4.46	5.71	9.53	18.2	32.5
	1160	1.45	2.40	3.89	3.91	5.71	9.53	11.5	27.7
	960	1.24	2.10	3.45	3.50	5.71	9.53	11.2	24.6
	725	1.07	1.69	2.70	2.79	5.31	9.02	10.0	20.6
	480	0.74	1.22	1.93	1.99	4.11	7.12	9.85	14.6
16 - 28	2900	1.70	2.76	3.07	3.73	Consult our Application engineers			
	1750	1.28	2.03	3.48	3.53				
	1450	1.09	1.62	3.18	3.20	4.95	7.41	12.9	19.4
	1160	0.92	1.37	2.78	2.80	4.81	7.27	11.8	17.0
	960	0.83	1.26	2.45	2.49	4.48	6.91	10.7	14.9
	725	0.67	0.96	1.97	2.02	3.96	6.91	8.71	12.4
	480	0.47	0.66	1.64	1.66	2.90	4.87	6.50	8.78
32 - 71	2900	1.22	2.15	3.20	4.41	7.26	9.64	18.6	36.1
	1750	0.84	1.44	2.35	3.70	5.44	7.35	13.0	23.3
	1450	0.69	1.15	2.05	3.26	4.88	7.32	11.6	20.1
	1160	0.57	0.95	1.72	2.79	4.44	7.06	10.9	16.6
	960	0.51	0.85	1.55	2.43	3.97	6.47	8.76	14.1
	725	0.40	0.66	1.18	1.78	3.53	5.15	7.25	11.0
	480	0.33	0.45	0.87	1.28	2.50	3.70	5.37	7.53
	250	0.18	0.30	0.54	0.70	1.33	2.25	2.97	4.07

Table 2. Thermal service factor Ft

Thermal service factor for ambient temperature

Ambient temperature	-30	-20	-10	0	10	20	30	40	50
Factor	1.68	1.55	1.41	1.27	1.14	1.0	0.84	0.68	0.50

Table 3. Thermal service factor Fp

Thermal service factor for mounting positions

Unit Output Speed (Rev/min)			Mounting Position				
			1	2 & 3	4	5	6
0	to	25	1.00	0.997	0.996	0.995	0.993
>25	to	50	1.00	0.993	0.990	0.986	0.982
>50	to	75	1.00	0.987	0.981	0.974	0.968
>75	to	100	1.00	0.980	0.970	0.960	0.950
>100	to	200	1.00	0.943	0.914	0.886	0.858
>200	to	300	1.00	0.896	0.844	0.792	0.840
>300	to	400	1.00	0.840	0.760	0.680	0.600
>400			1.00	0.809	0.724	0.618	0.533

Table 4. Thermal service factor Fd

Thermal service factor for duration of running

Unit Output Speed (Rev/min)			% Running time per hour				
			100	80	60	40	20
0	to	10	1.00	1.18	1.45	1.72	2.38
>10	to	25	1.00	1.16	1.39	1.64	2.22
>25	to	50	1.00	1.14	1.31	1.54	2.00
>50	to	100	1.00	1.08	1.19	1.33	1.64
>100	to	150	1.00	1.04	1.08	1.19	1.41
>150	to	200	1.00	1.00	1.00	1.06	1.23
>200			1.00	1.00	1.00	1.00	1.00

SERIES C

FAN COOLED UNITS

Table 5. Thermal Power (Kw) With Cooling Fan

Overall ratios	Input RPM	C03	C04	C05	Size C06	C07	C08	C09	C10
8 - 14	2900	-	-	-	-	Consult our Application engineers			
	1750	-	-	-	-				
	1450	-	-	-	-	11,4	19,1	36,4	65,0
	1160	-	-	-	-	10,6	17,6	22,5	52,2
	960	-	-	-	-	10,0	16,7	19,6	43,0
	725	-	-	-	-	8,00	13,5	15,0	30,9
16 - 28	2900	-	-	-	-	Consult our Application engineers			
	1750	-	-	-	-				
	1450	-	-	-	-	11,3	17,7	30,9	51,2
	1160	-	-	-	-	11,2	17,5	30,6	50,6
	960	-	-	-	-	9,90	14,8	25,8	38,8
	725	-	-	-	-	8,90	13,4	21,8	31,5
						7,84	12,1	18,7	26,1

Note: When checking thermal capacities use actual load required to be transmitted, not rating of prime mover.

Column 10 Entry

For reducer fan kit modules enter S in column 10
 or if used in conjunction with a reducer backstop module kit

Y CW rotation
Z CCW rotation

Dimensions of Fan Cooled Units

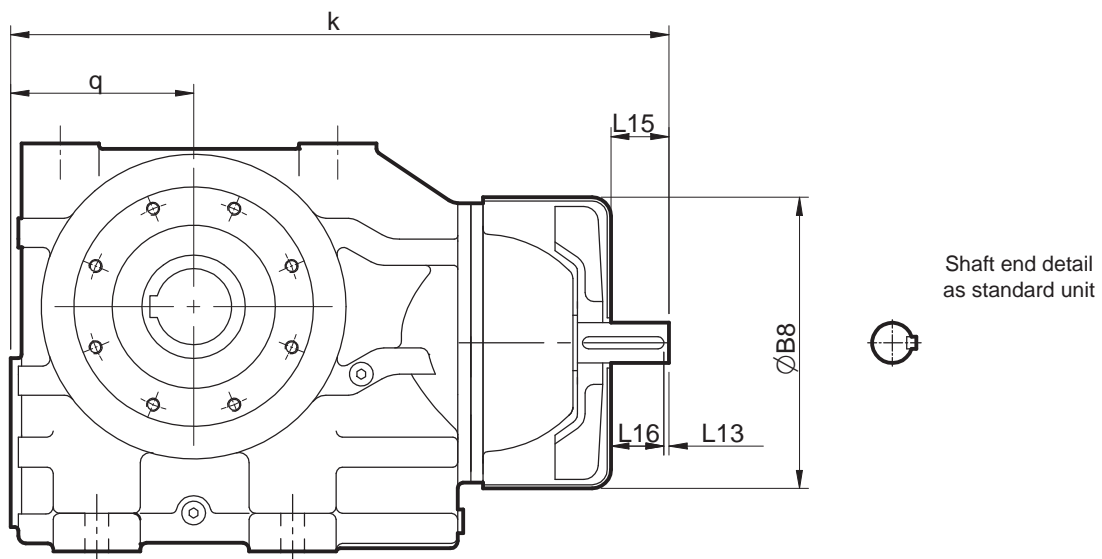

Size	øB8	k	L13	L15	L16	q
C0721	225	478	5	35	30	143
C0821	265	583	5	45	40	168
C0921	320	690	5	65	60	195
C1021	380	823	10	95	85	235

SERIES C

REDUCER BACKSTOP MODULE

The reducer units listed below can be fitted with an internal backstop, this has no effect of the external unit size. The backstop device incorporates high quality centrifugal lift off sprags which are wear free above the lift off speed (n min). To ensure correct operation input speed must exceed lift off speed.

Suitable for ambient temperature -40°C to + 50°C

Column 10 Entry

For reducer fan kit modules enter

W

for CCW rotation (or

Z

if used in conjunction with a fan kit)

X

for CW rotation (or

Y

if used in conjunction with a fan kit)

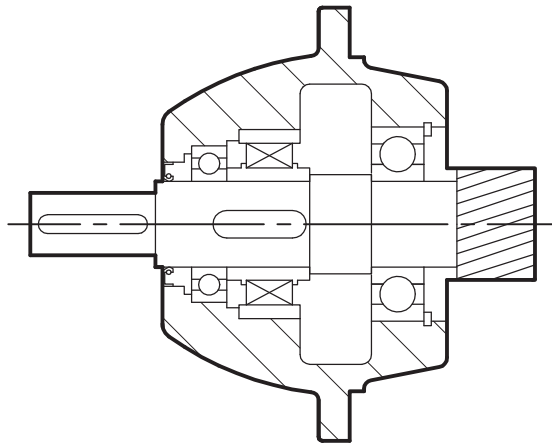

Size	Lift off speed ('n min) at inputshaft (rev/min)	Rated locking Torque ('T max') at inputshaft (Nm)
C0622/C0842/C0941	800	100
C0722/C1041	670	170
C0822	670	300
C0921	620	940
C1021	550	1260

Rotation of outputshaft must be specified when ordering as viewed from the outputshaft end (as shown in the diagram)

CW	-	Free Rotation	-	Clockwise
		Locked	-	Anticlockwise
AC	-	Free Rotation	-	Anticlockwise
		Locked	-	Clockwise

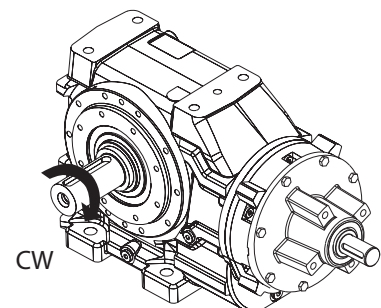

SERIES C

DIMENSIONS

OUTPUTSHAFT OPTIONS

STANDARD OUTPUTSHAFT OPTION

STANDARD DOUBLE EXTENDED OUTPUTSHAFT OPTION

C03 - C06

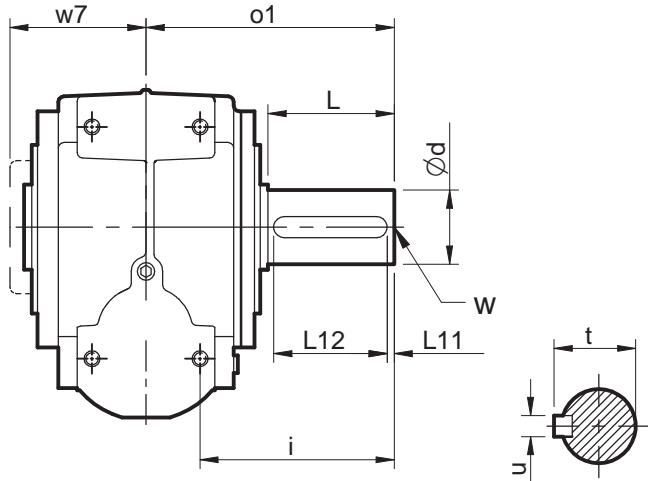

C03 - C06

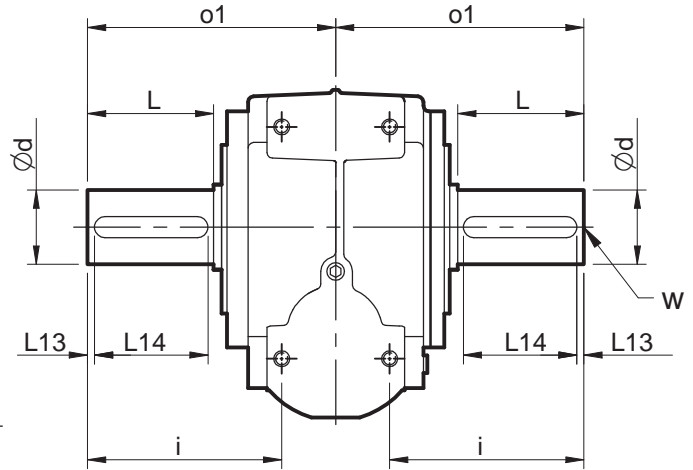

C07 - C10

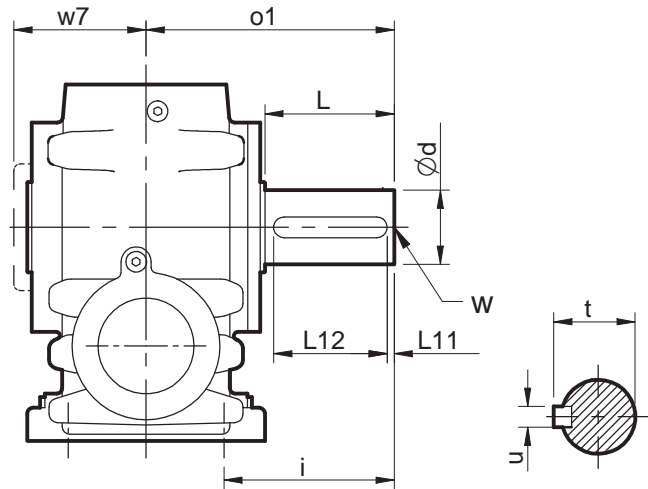

C07 - C10

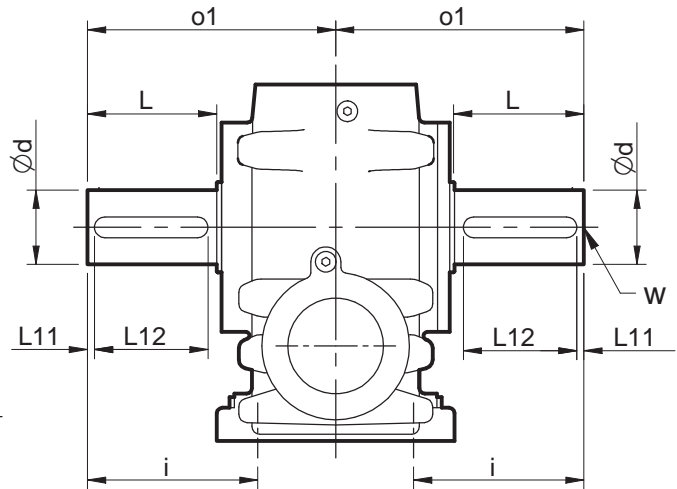

Size	ød	i	L	L11	L12	o1	t	u	w	w7
C0321	20,015 / 20,002	73	35	3	31	100	22,5	6	M8 x 1.0 x 16	70
C0421	25,015 / 25,002	87	46	3	42	115	28	8	M10 x 1.5 x 22	74,8
C0521	30,015 / 30,002	100	60	3	53	134	33	8	M10 x 1.5 x 22	79
C0621	35,018 / 35,002	120	63	3	55	160	38	10	M12 x 1.75 x 25	101
C0621 Heavy duty	45,018 / 45,002	155	98	5	80	195	48,5	14	M12 x 1.75 x 25	101
C0721	45,018 / 45,002	120	76	3	70	195	48,5	14	M16 x 2.0 x 36	125
C0821	60,030 / 60,011	155	120	3	110	255	64	18	M20 x 2.5 x 42	143
C0921	70,030 / 70,011	170	135	3	125	295	74,5	20	M20 x 2.5 x 42	169
C1021	90,035 / 90,013	216	170	3	160	366	95	25	M24 x 3.0 x 50	198

SERIES C

TORQUE ARM

It is recommended that the torque arm is positioned such that the it is fitted on the side of the unit adjacent to the driven machine.

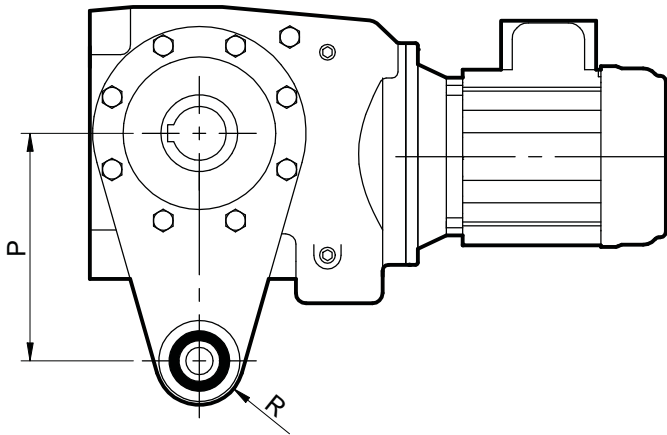

Column 9 Entry

T
Left

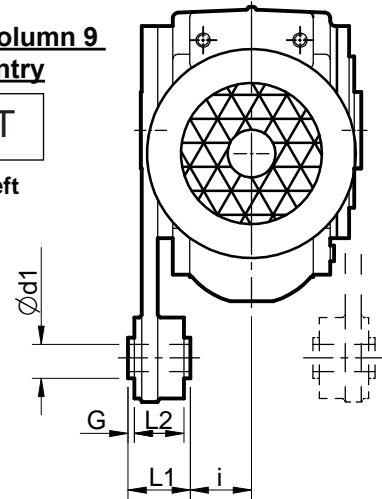

Column 9 Entry

Q
Right

Size	d1	G	i	L1	L2	P	R
C03	10.3	2	47	36	32	110	23
C04	10.3	2	52	36	32	130	23
C05	10.3	2	52	36	32	160	23
C06	16.3	2	71.5	44	32	200	38

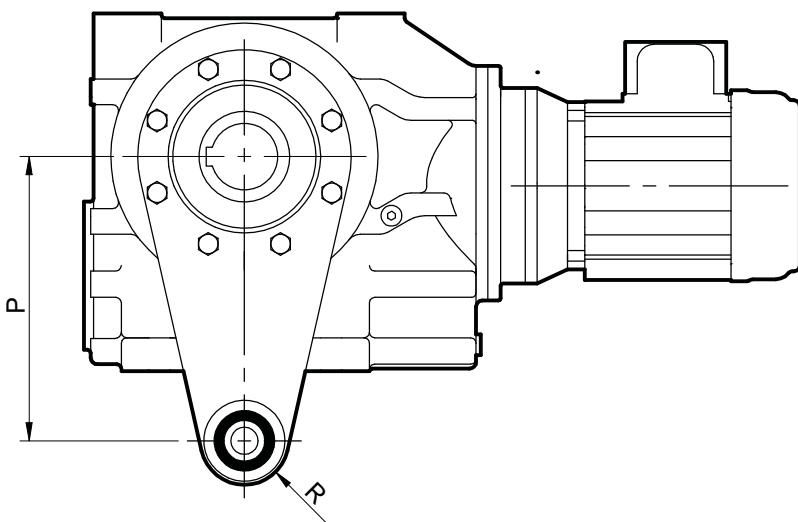

Column 9 Entry

T
Left

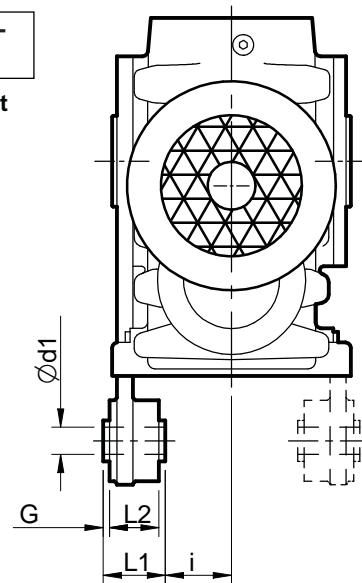

Q
Right

Size	$\phi d1$	G	i	L1	L2	P	R
C07	16.3	2	77.5	60	56	250	38
C08	16.3	2	85.5	60	56	310	38
C09	25	5	98	80	70	380	45
C10	25	5	137	80	70	430	45

SERIES C

DIMENSIONS

D (B5) FLANGE

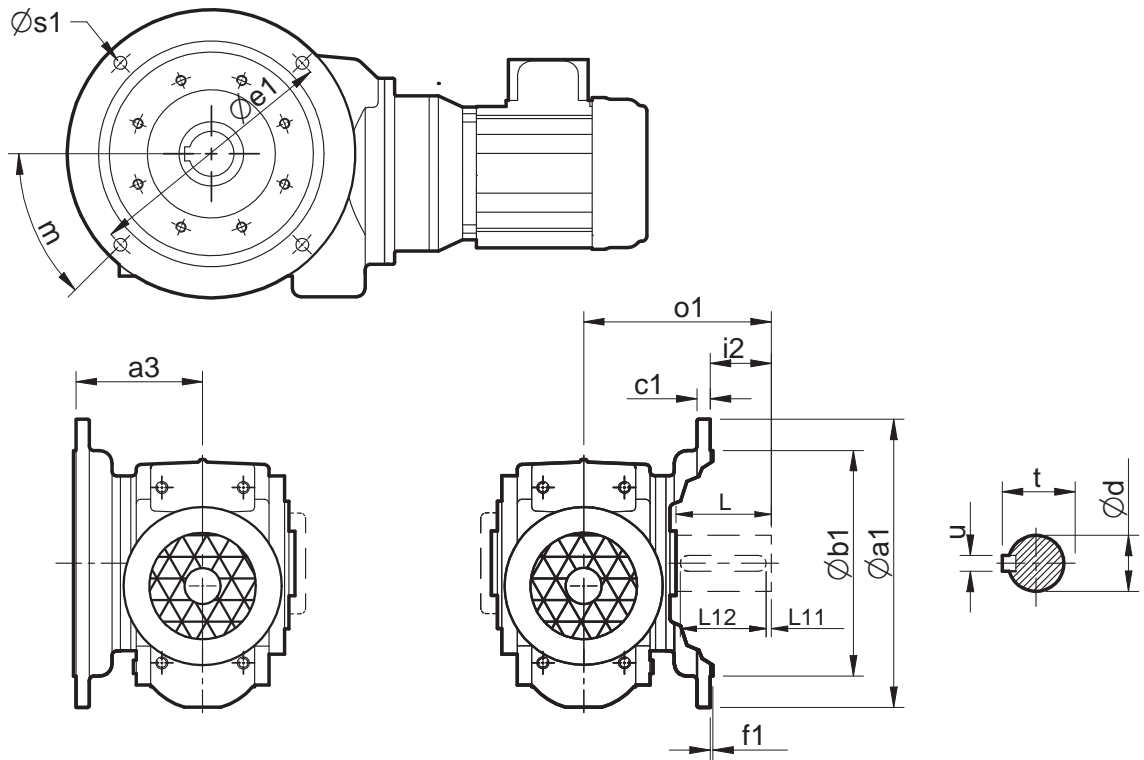

Column 9 Entry

F Left

Column 9 Entry

H Right

Size	Øa1	a3	Øb1	c1	Øe1	f1	m	Øs1
C03 Red Dia.	120	75	80 j6	8	100	3	45°	6.6
C03	160	75	110 j6	10	130	4	45°	9
C04	160	86	110 j6	10	130	3.5	45°	9
C05	200	107	130 j6	12	165	3.5	45°	11
C06	200	120	130 j6	12	165	3.5	45°	11
C07	250	145	180 j6	12	215	4	45°	14
C08	350	170	250 h6	18	300	5	45°	18
C09	450	200	350 h6	20	400	5	22.5°	18
C10	450	232	350 h6	22	400	5	22.5°	18

Size	Ød	i 2	L	L11	L12	o	t	u	v
C0321	20.015 / 20.002	27	35	3	31	100	22.5	6	M8 x 1.0 x 16
C0421	25.015 / 25.002	40	46	3	42	115	28	8	M10 x 1.5 x 22
C0521	30.015 / 30.002	48	60	3	53	134	33	8	M10 x 1.5 x 22
C0621	35.018 / 35.002	53	63	3	55	160	38	10	M12 x 1.75 x 22
C0621 Heavy duty	45.018 / 45.002	75	98	5	80	195	48.5	14	M12 x 1.75 x 22
C0721	45.018 / 45.002	50	76	3	70	195	48.5	14	M16 x 2.0 x 36
C0821	60.030 / 60.011	85	120	3	110	255	64	18	M20 x 2.5 x 42
C0921	70.030 / 70.011	95	135	3	125	295	74.5	20	M20 x 2.5 x 42
C1021	90.035 / 90.013	134	170	3	160	366	95	25	M24 x 3.0 x 50

SERIES C

DIMENSIONS

C (B14) FLANGE

C04, C05, C06, C08

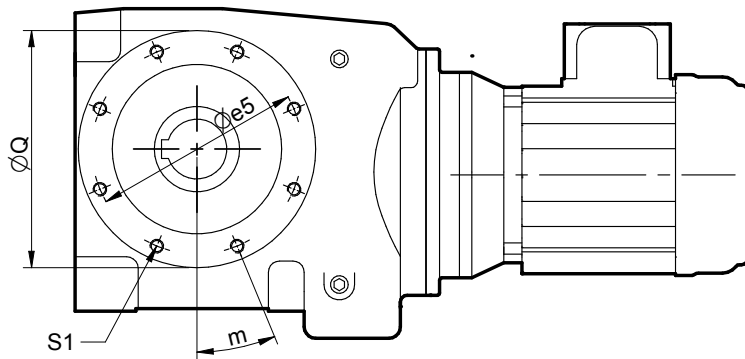

C03

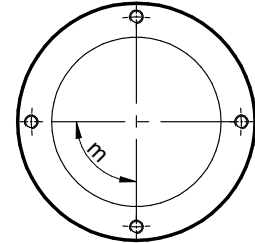

C07, C09

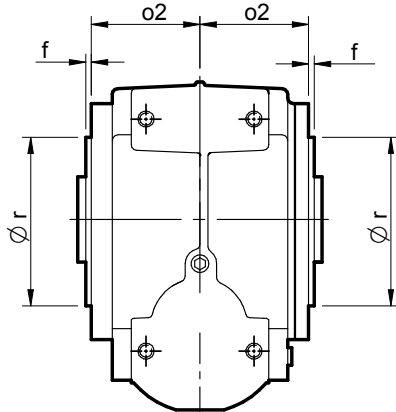
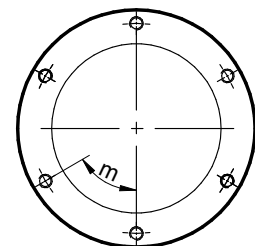

C03 - C06

Male spigot

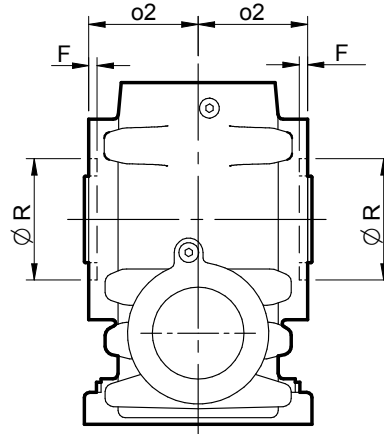

C07 - C10

Female recess

C10

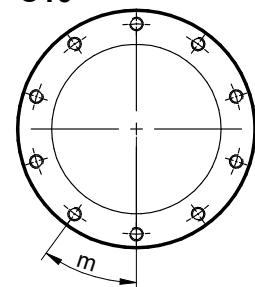

Size	øe5	f	F	m	o2	ø Q	ø r (h7)	ø R (H7)	S1
C03	90	4	-	90°	57	106	70	-	(4) M8 x 1.25 x 22
C04	107	4	-	22.5°	57	122	85	-	(8) M8 x 1.25 x 22
C05	130	4	-	22.5°	62	146	105	-	(8) M8 x 1.25 x 22
C06	155	5	-	22.5°	81	175	125	-	(8) M10 x 1.5 x 22
C07	150	-	4.5	60°	104	180	-	130	(6) M12 x 1.75 x 22
C08	195	-	5.0	22.5°	120	220	-	150	(8) M12 x 1.75 x 22
C09	230	-	5.0	60°	144	280	-	180	(6) M16 x 2.0 x 27
C10	280	-	7.0	36°	167	360	-	210	(10) M16 x 2.0 x 27

SERIES C

AGITATOR UNITS

AGITATOR - Non Standard Special Build.
Please consult our Application Engineers

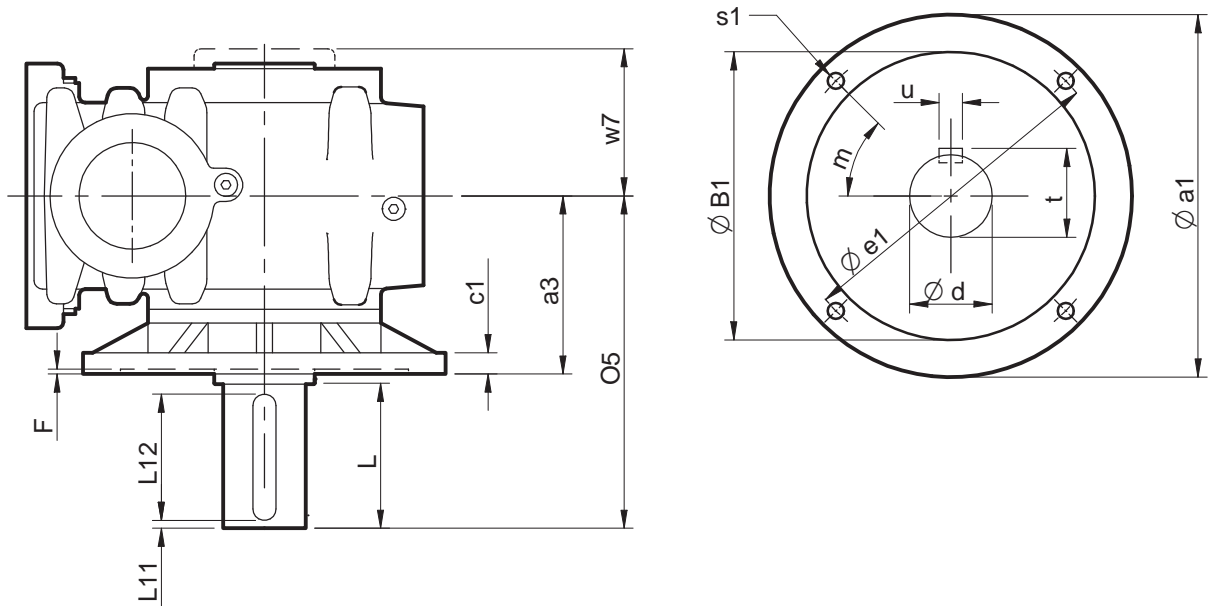

Size	a1	a3	B1 (H7)	c1	d (m6)	e1	F	L	L11	L12	m	O5	S	t	u	w7
C07	300	160	230	16	65	265	6	125	5	110	45°	290	(4) Ø 15	69	18	125
C08	350	180	250	17	75	300	7	140	5	125	45°	325	(4) Ø 19	79.5	20	143
C09	400	200	300	20	85	350	7	155	5	140	45°	360	(4) Ø 19	90	22	169
C10	450	212	350	22	100	400	7	175	5	160	22.5°	392	(8) Ø 19	106	28	198

SERIES C

DIMENSIONS

STANDARD BORE ASSEMBLY

ASSEMBLY ONTO SHAFT - CUSTOMERS SHAFT DETAIL

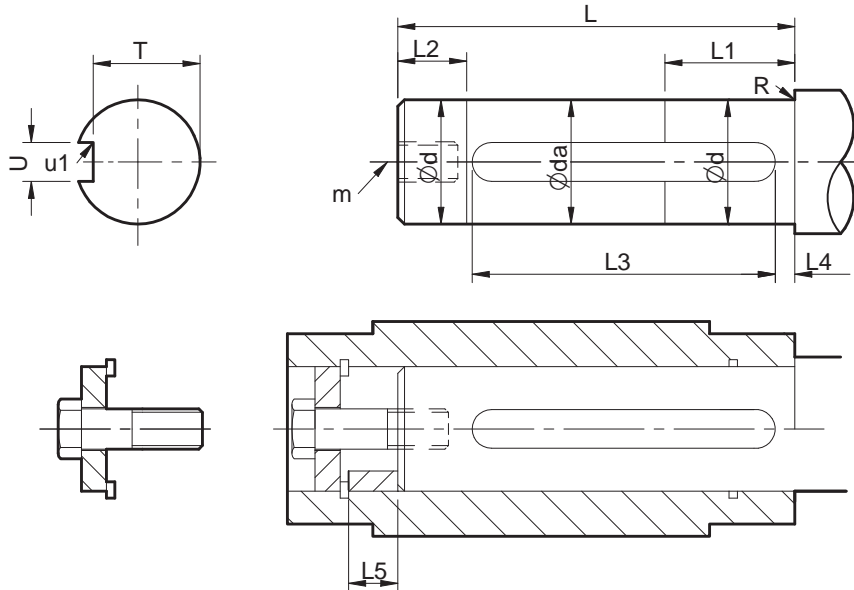

Size	Bore	d	da	L	L1	L2	L3	L4	L5	m	N	R	T	U	u1
C03	Std	19.993/ 19.980	19.6	82	30	10	61.3 61.0	3	22	M6x1.0x16	8 Nm	0.8R	16.5 16.4	6.000 / 5.970	0.16 0.25R
	Reduced	24.993/ 24.980	24.6	99	38	13	79.3 79.0	3	23	M10x1.5x22	15 Nm	0.8R	21.0 20.8	8.000 / 7.964	0.16 0.25R
C04	Std	29.993/ 29.980	29.6	99	45	15	79.3 79.0	3	26	M10x1.5x22	15 Nm	0.8R	26.0 25.8	8.000 / 7.964	0.16 0.25R
	Reduced	29.993/ 29.980	29.6	104	45	15	79.3 79.0	3	23	M10x1.5x22	15 Nm	0.8R	26.0 25.8	8.000 / 7.964	0.16 0.25R
C05	Std	34.991/ 34.975	34.6	104	53	18	77.3 77.0	3	23	M12x1.75x28	20 Nm	0.8R	30.0 29.8	10.000 / 9.964	0.16 0.25R
	Reduced	34.991/ 34.975	34.6	125	60	20	100.5 100.0	3	31	M16x2x36	45 Nm	0.8R	35.0 34.8	12.000 / 11.957	0.4 0.25R
C06	Std	44.991/ 44.975	44.6	125	68	23	101.5 101.0	3	31	M16x2x36	45 Nm	0.8R	39.5 39.3	14.000 / 13.957	0.4 0.25R
	Reduced	49.991/ 49.975	49.6	153	75	25	130.5 130.0	3	35	M16x2x38	45 Nm	1.2R	44.5 44.3	14.000 / 13.957	0.4 0.25R
C07	Std	59.990 / 59.971	59.6	153	90	30	148.5 148.0	3	38	M20x2.5x42	85 Nm	1.2R	53.0 52.8	18.000 / 17.957	0.4 0.25R
	Reduced	59.990 / 59.971	59.6	183	91	31	148.5 148.0	3	37	M20x2.5x42	85 Nm	1.2R	53.0 52.8	18.000 / 17.957	0.4 0.25R
C08	Std	69.990 / 69.971	69.6	183	105	35	177.5 177.0	3	37	M20x2.5x42	85 Nm	1.2R	62.5 62.3	20.000 / 19.94	0.6 80.4R
	Reduced	69.990 / 69.971	69.6	227	105	35	177.5 177.0	3	58	M20x2.5x42	85 Nm	1.2R	62.5 62.3	20.000 / 19.94	0.6 80.4R
C09	Std	89.988 / 89.966	89.6	227	135	45	221.5 221.0	3	58	M24x3.0x50	200 Nm	1.2R	81.0 80.8	25.000 / 24.948	0.6 0.4R
	Reduced	79.990 / 79.971	79.6	260	120	40	225.5 225.0	3	53	M20x2.5x42	85 Nm	1.2R	71.0 70.8	22.000 / 21.946	0.6 0.4R
C10	Std	99.988/ 99.966	99.6	327	150	45	238.5 238.0	10	46	M24x3x50	200 Nm	1.2R	90 89.8	28.000/ 27.948	0.4 0.4R
	Reduced	99.988/ 99.966	99.6	327	150	45	238.5 238.0	10	46	M24x3x50	200 Nm	1.2R	90 89.8	28.000/ 27.948	0.4 0.4R

Assembly Instructions

1. Spray the hollow shaft bore and mating diameter of the output shaft with Rocol DFSM or equivalent antiscuffing spray.
2. Fit key into shaft.
3. Fit the circlip into the output sleeve.
4. Fit the spacer tube only if the output shaft has no shoulder, then fit the output shaft into the output sleeve.
5. Secure in place with the washer and bolt. Torque tighten to the values stated in column N of the above table.
6. Fit plastic protective cover.

SERIES C

DIMENSIONS

STANDARD BORE DISASSEMBLY

DISASSEMBLY METHOD FROM SHAFT

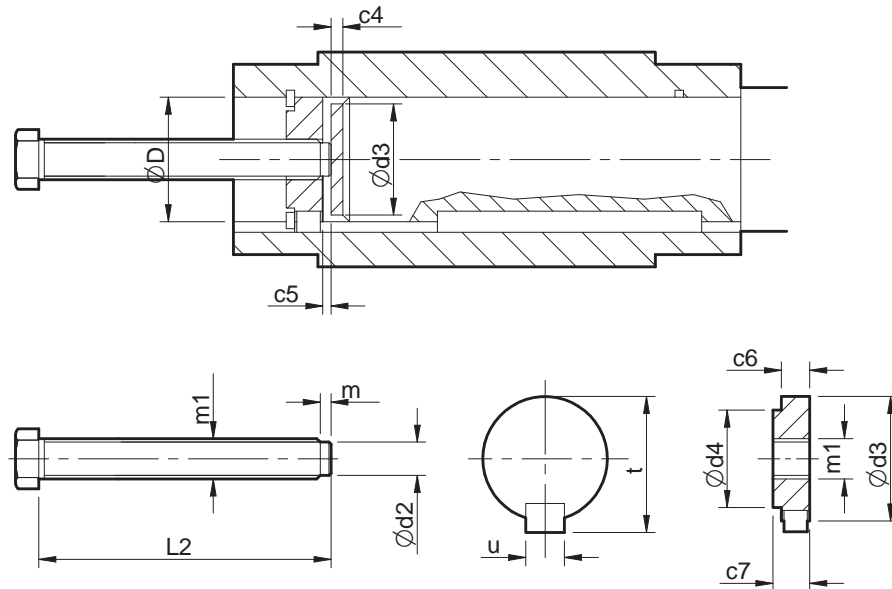

PARTS SUPPLIED BY CUSTOMER

Size	Bore	c4	c6	c7	D (H7)	d2	d3	d4	L2	m	m1	t	u
C03	Std	5	10	12	20	7	19.9	11.2	120	3	M10 x 1.5	22	6
C04	Reduced	5	15	17	25	13	24.9	16.2	160	3	M16 x 2.0	2	8
	Std	5	15	17	30	13	29.9	20.8	160	3	M16 x 2.0	33	8
C05	Reduced	5	15	17	30	13	29.9	20.8	160	3	M16 x 2.0	33	8
	Std	5	15	17	35	13	34.9	25.2	160	3	M16 x 2.0	38	10
C06	Reduced	5	20	23	40	20	39.9	30.9	220	3	M24 x 3.0	43	12
	Std	5	20	23	45	20	44.9	34.1	220	3	M24 x 3.0	49	14
C07	Reduced	5	20	23	50	20	49.9	39.0	220	3	M24 x 3.0	54	14
	Std	8	24	27	60	26	59.9	47.4	250	5	M30 x 3.5	64	1
C08	Reduced	8	24	27	60	26	59.9	47.4	250	5	M30 x 3.5	64	1
	Std	8	24	27	70	26	69.9	58.4	310	5	M30 x 3.5	74.5	20
C09	Reduced	8	24	27	70	26	69.9	58.4	310	5	M30 x 3.5	74.5	20
	Std	8	24	27	90	26	89.9	75.3	360	5	M30 x 3.5	95	25
C10	Reduced	8	24	27	80	26	79.9	65.5	360	5	M30 x 3.5	85	22
	Std	8	30	34	100	32	99.9	84.1	420	5	M30 x 3.5	106	2

SERIES C

SHIPPING SPECIFICATION

BASE MOUNT UNITS WITH STANDARD HOLLOW SHAFT

Unit size & No off reductions		C0321	C0331	C0341	C0421	C0431	C0441	C0521	C0531	C0541	C0621	C0631	C0641	C0721	C0731	C0741	C0821	C0841	C0921	C0941	C1021	C1041	
Reducer Version		11	14	20	15	18	23	18	21	28	32	38	43	74	81	83	117	143	181	204	326	372	
Single Output Shaft		0.4			1.0			1.5			3.7			7.0			12		19		30		
Double Output Shaft		0.6			1.5			2.3			5.6			11			18		28		45		
Motorised	63	Without Motor	12	13	20	16	17	24	18	19	29	28	33	44		80	83						
		With Motor	16	17	25	20	21	29	23	24	33	32	37	48		84	88						
	71	Without Motor	11	13	20	15	17	24	18	19	28	28	33	44		80	83						
		With Motor	18	19	26	22	23	30	25	26	35	34	39	50		87	89						
	80A	Without Motor	12	14	20	16	18	24	19	22	29	31	35	44	71	80	83	118	143	174	204		369
		With Motor	21	23	30	25	27	34	28	31	38	39	43	54	80	88	93	127	152	183	213		37
	80B	Without Motor	12	14	20	16	18	24	19	22	29	31	35	44	71	80	83	118	143	174	204		369
		With Motor	23	25	31	27	29	35	30	33	40	42	46	55	82	91	94	129	154	185	215		380
	90S	Without Motor	13	15	21	16	18	25	19	22	30	32	35	45	72	80	84	118	144	174	205		370
		With Motor	26	28	35	30	32	39	33	36	43	46	50	58	85	94	98	131	157	187	218		383
	90L	Without Motor	13	15	21	16	18	25	19	22	30	32	35	45	72	80	84	118	144	174	205		370
		With Motor	27	29	36	31	33	40	34	37	44	47	52	59	86	95	99	132	158	188	219		374
	100L	Without Motor										35			74			120	146	176	207	313	372
		With Motor										59			98			144	170	200	231	337	396
	112M	Without Motor										35			74			120	146	176	207	313	372
		With Motor										66			105			151	177	207	238	344	403
	132S	Without Motor													76			123		179		316	374
		With Motor													124			171		227		364	422
	132M	Without Motor													76			123		179		316	374
		With Motor													128			175		231		368	426
	160M	Without Motor																128		184		321	
		With Motor																241		297		434	
	160L	Without Motor																128		184		321	
		With Motor																261		317		454	
	180M	Without Motor																		197		334	
		With Motor																		364		501	
	180L	Without Motor																		197		334	
		With Motor																		378		515	
200L	Without Motor																		201		338		
	With Motor																		433		570		
225S	Without Motor																		205		342		
	With Motor																		492		629		
225M	Without Motor																		205		342		
	With Motor																		527		664		

ALL WEIGHTS IN KG ALL WEIGHTS EXCLUDE LUBRICANT AND ARE FOR STANDARD SHAFT MOUNT UNITS, FOR BASE MOUNT UNITS ADD WEIGHT OF SHAFT (SHOWN AT TOP OF TABLE) TO THE FIGURES SHOWN ABOVE

IMPORTANT

Product Safety Information

General - The following information is important in ensuring safety. It **must** be brought to the attention of personnel involved in the selection of the equipment, those responsible for the design of the machinery in which it is to be incorporated and those involved in its installation, use and maintenance.

The equipment will operate safely provided it is selected, installed, used and maintained properly. As with any power transmission equipment **proper precautions must** be taken as indicated in the following paragraphs, to ensure safety.

Potential Hazards - these are **not** necessarily listed in any order of severity as the degree of danger varies in individual circumstances. It is important therefore that the list is studied in its entirety:-

- 1) Fire/Explosion
 - (a) Oil mists and vapour are generated within gear units. It is therefore dangerous to use naked lights in the proximity of gearbox openings, due to the risk of fire or explosion.
 - (b) In the event of fire or serious overheating (over 300 °C), certain materials (rubber, plastics, etc.) may decompose and produce fumes. Care should be taken to avoid exposure to the fumes, and the remains of burned or overheated plastic/rubber materials should be handled with rubber gloves.
- 2) Guards - Rotating shafts and couplings must be guarded to eliminate the possibility of physical contact or entanglement of clothing. It should be of rigid construction and firmly secured.
- 3) Noise - High speed gearboxes and gearbox driven machinery may produce noise levels which are damaging to the hearing with prolonged exposure. Ear defenders should be provided for personnel in these circumstances. Reference should be made to the Department of Employment Code of Practice for reducing exposure of employed persons to noise.
- 4) Lifting - Where provided (on larger units) only the lifting points or eyebolts must be used for lifting operations (see maintenance manual or general arrangement drawing for lifting point positions). Failure to use the lifting points provided may result in personal injury and/or damage to the product or surrounding equipment. Keep clear of raised equipment.
- 5) Lubricants and Lubrication
 - (a) Prolonged contact with lubricants can be detrimental to the skin. The manufacturer's instruction must be followed when handling lubricants.
 - (b) The lubrication status of the equipment must be checked before commissioning. Read and carry out all instructions on the lubricant plate and in the installation and maintenance literature. Heed all warning tags. Failure to do so could result in mechanical damage and in extreme cases risk of injury to personnel.
- 6) Electrical Equipment - Observe hazard warnings on electrical equipment and isolate power before working on the gearbox or associated equipment, in order to prevent the machinery being started.
- 7) Installation, Maintenance and Storage
 - (a) In the event that equipment is to be held in storage, for a period exceeding 6 months, prior to installation or commissioning, application engineering must be consulted regarding special preservation requirements. Unless otherwise agreed, equipment must be stored in a building protected from extremes of temperature and humidity to prevent deterioration.

The rotating components (gears and shafts) must be turned a few revolutions once a month (to prevent bearings brinelling).
 - (b) External gearbox components may be supplied with preservative materials applied, in the form of a "waxed" tape overwrap or wax film preservative. Gloves should be worn when removing these materials. The former can be removed manually, the latter using white spirit as a solvent.

Preservatives applied to the internal parts of the gear units do not require removal prior to operation.
 - (c) Installation must be performed in accordance with the manufacturer's instructions and be undertaken by suitably qualified personnel.
 - (d) Before working on a gearbox or associated equipment, ensure that the load has been removed from the system to eliminate the possibility of any movement of the machinery and isolate power supply. Where necessary, provide mechanical means to ensure the machinery cannot move or rotate. Ensure removal of such devices after work is complete.
 - (e) Ensure the proper maintenance of gearboxes in operation. Use only the correct tools and approved spare parts for repair and maintenance. Consult the Maintenance Manual before dismantling or performing maintenance work.
- 8) Hot Surfaces and Lubricants
 - (a) During operation, gear units may become sufficiently hot to cause skin burns. Care must be taken to avoid accidental contact.
 - (b) After extended running the lubricant in gear units and lubrication systems may reach temperatures sufficient to cause burns. Allow equipment to cool before servicing or performing adjustments.
- 9) Selection and Design
 - (a) Where gear units provide a backstop facility, ensure that back-up systems are provided if failure of the backstop device would endanger personnel or result in damage.
 - (b) The driving and driven equipment must be correctly selected to ensure that the complete machinery installation will perform satisfactorily, avoiding system critical speeds, system torsional vibration, etc.
 - (c) The equipment must not be operated in an environment or at speeds, powers, torques or with external loads beyond those for which it was designed.
 - (d) As improvements in design are being made continually the contents of this catalogue are not to be regarded as binding in detail, and drawings and capacities are subject to alterations without notice.

The above guidance is based on the current state of knowledge and our best assessment of the potential hazards in the operation of the gear units.

Any further information or clarification required may be obtained by contacting an Application Engineer.

CONTACT US

AUSTRALIA

Radicon Transmission (Australia) PTY Ltd

Australia
Tel: +61 488 054 028

EUROPE

Benzler TBA BV Jachthavenweg 2 NL-5928 NT Venlo

Austria
Tel: +43 7 229 618 91
Fax: +43 7 229 618 84

Germany
Tel: 0800 350 40 00
Fax: 0800 350 40 01

Italy
Tel: +39 02 824 3511

Netherlands & the rest of Europe
Tel: +31 77 324 59 00
Fax: +31 77 324 59 01

DENMARK

Benzler Transmission A/S

Dalager 1
DK-2605 Brøndby,
Denmark

Tel: +45 36 34 03 00
Fax: +45 36 77 02 42

FINLAND

Oy Benzler AB Vanha Talvitie 3C FI-00580 Helsingfors, Finland

Tel: +358 9 340 1716
Fax: +358 10 296 2072

INDIA

Elecon. Engineering Company Ltd.

Anand Sojitra Road
Vallabh Vidyanagar
388120 Gujarat
India

Tel: +91 2692 236513
Fax: +91 2692 227484

SWEDEN & NORWAY

AB Benzlers

Porfyrgatan
254 68 Helsingborg
Sweden

Tel: +46 42 18 68 00
Fax: +46 42 21 88 03

THAILAND

Radicon Transmission (Thailand) Ltd 700/43 Moo 6 Amata Nakorn Industrial Estate Tumbol Klontumru Muang, Chonburi 20000 Thailand

Tel: +66 3845 9044
Fax: +66 3821 3655

UNITED KINGDOM

Radicon Transmission UK Ltd

Unit J3
Lowfields Business Park,
Lowfields Way, Elland
West Yorkshire, HX5 9DA

Tel: +44 (0) 1484 465 800
Fax: +44 (0) 1484 465 801

USA

Radicon USA Transmission Ltd

1599 Lunt Avenue
Elk Grove Village
Chicago
Illinois
60007
USA

Tel: +1 847 593 9910
Fax: +1 847 593 9950

www.benzlers.com

www.radicon.com

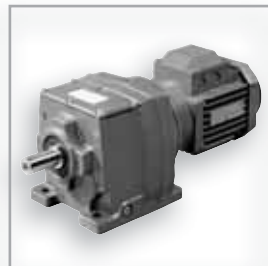
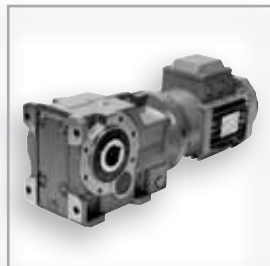
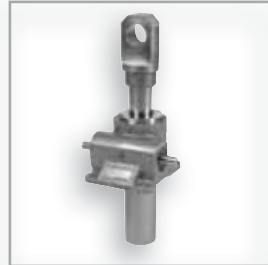

benzlers[☼]
radicon[☼]

Benzlers

Denmark +45 36 34 03 00

Germany +49 800-350 4000

Finland +358 9 340 1716

Italy +39 02 824 3511

Sweden +46 42 186 800

+46 19 178 090

The Netherlands +31 77 324 59 00

www.benzlers.com

Radicon

France +33 625 727306

South Africa +27 740 787979

Spain +34 615 275990

Thailand +66 3845 9044

United Kingdom +44 (0) 1484 465 800

USA +1 847 593 9910

www.radicon.com